

# Operating and installation instructions

## Manifolds for condensate collection and steam distribution

### CODI<sup>®</sup>S / CODI<sup>®</sup>B (PN40 - 63)

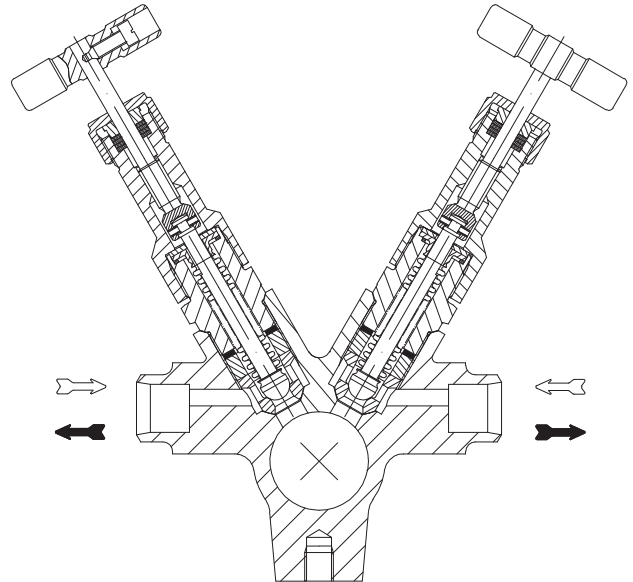
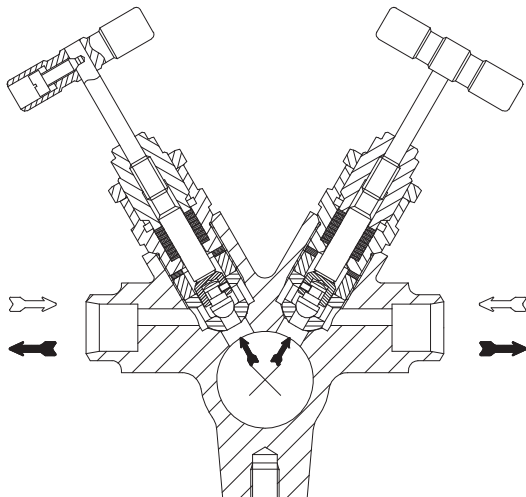

**CODI<sup>®</sup> S**  
**with stuffing box**  
**PN40 / PN63**  
 series 671 (vertical installation)  
 series 672 (horizontal installation)

- with socket weld ends (CODI<sup>®</sup> ...-02 to ...-18)
- with butt weld ends (CODI<sup>®</sup> ...-02 to ...-18)

**CODI<sup>®</sup> B**  
**with bellows seal**  
**PN40 / PN63**  
 series 675 (vertical installation)  
 series 676 (horizontal installation)

- with socket weld ends (CODI<sup>®</sup> ...-02 to ...-18)
- with butt weld ends (CODI<sup>®</sup> ...-02 to ...-18)

### Contents

<b>1.0 General information on operating instructions</b> .....	<b>2-2</b>	<b>6.0 Putting the valve into operation</b> .....	<b>2-7</b>
<b>2.0 Notes on possible dangers</b> .....	<b>2-2</b>	<b>7.0 Care and maintenance</b> .....	<b>2-8</b>
2.1 Significance of symbols .....	2-2	7.1 Disassembling/assembling complete shut-off valve assembly.....	2-8
2.2 Explanatory notes on safety information .....	2-2	7.2 Replacing the packing rings (CODI <sup>®</sup> S).....	2-8
<b>3.0 Storage and transport</b> .....	<b>2-2</b>	7.3 Replacing packing rings of the secondary sealing gland packing (CODI <sup>®</sup> B) .....	2-9
<b>4.0 Description</b> .....	<b>2-3</b>	7.4 Insulating jacket option .....	2-10
4.1 Scope of applications .....	2-3	7.5 Tightening torques.....	2-11
4.2 Operating principles .....	2-3	<b>8.0 Troubleshooting</b> .....	<b>2-11</b>
4.2.1 Condensate collection manifold .....	2-4	<b>9.0 Troubleshooting table</b> .....	<b>2-11</b>
4.2.2 Steam distribution manifolds .....	2-4	<b>10.0 Dismantling the valve or the body</b> .....	<b>2-12</b>
4.3 Diagram.....	2-5	<b>11.0 Warranty / Guarantee</b> .....	<b>2-12</b>
4.4 Technical data - remarks .....	2-6		
4.5 Marking .....	2-6		
<b>5.0 Installation</b> .....	<b>2-6</b>		
5.1 General notes on installation.....	2-6		
5.2 Installation instructions for welding .....	2-7		
5.3 Installation position.....	2-7		

## 1.0 General information on operating instructions

These operating instructions provide information on mounting and maintaining the fittings. Please contact the supplier or the manufacturer in case of problems which cannot be solved by reference to the operating instructions.

They are binding on the transport, storage, installation, start-up, operation, maintenance and repair.

The notes and warnings must be observed and adhered to.

- Handling and all work must be carried out by expert personnel or all activities must be supervised and checked.

It is the owner's responsibility to define areas of responsibility and competence and to monitor the personnel.

- In addition, current regional safety requirements must be applied and observed when taking the fittings out of service as well as when maintaining and repairing them.

The manufacturer reserves the right to introduce technical modifications at any time.

These Operating Instructions comply with the requirements of EU Directives.

## 2.0 Notes on possible dangers

### 2.1 Significance of symbols

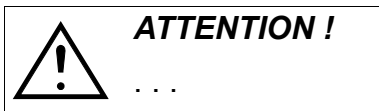

Warning of general danger.

### 2.2 Explanatory notes on safety information

In these Operating and Installation Instructions dangers, risks and items of safety information are highlighted to attract special attention.

Information marked with the above symbol and "**ATTENTION!**" describe practices, a failure to comply with which can result in serious injury or danger of death for users or third parties or in material damage to the system or the environment. It is vital to comply with these practices and to monitor compliance.

All other information not specifically emphasised such as transport, installation, operating and maintenance instructions as well as technical data (in the operating instructions, product documentation and on the device itself) must also be complied with to the fullest extent in order to avoid faults which in turn can cause serious injury to persons or damage to property.

## 3.0 Storage and transport

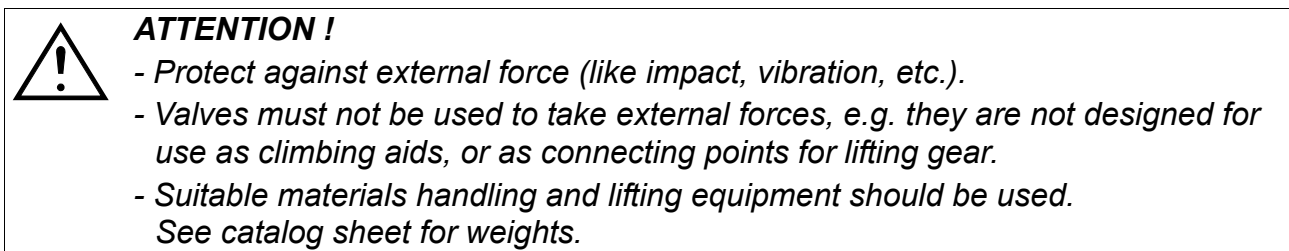

- At -20°C to +65°C.

- The paint is a base coat to protect against corrosion during transportation and storage. Do not damage paint protection.

## 4.0 Description

### 4.1 Scope of applications

Condensate collection/steam distribution manifolds are used for the discharge/distribution/ collection of condensate, steam or hot water.



#### **ATTENTION !**

- Refer to the data sheet for applications, limits on use and possibilities.
- Certain media require or preclude the use of special materials.
- The valves are designed for standard operating conditions. If conditions exceed these requirements, e.g. aggressive or abrasive media, the operator should state the higher requirements when ordering.
- Valves made from grey cast iron are not authorised for use in systems subject to TRD 110.

The information complies to the Pressure Equipment Directive 97/23/EC.

It is the responsibility of the machine planner to ensure compliance.

The special markings on the valve must be taken into account.

Refer to the catalogue sheet to see which materials are used in standard versions.

Please contact the supplier or the manufacturer if you have any questions.

### 4.2 Operating principles

(refer to Fig. 2 - Fig. 3 page 5)

The product concept is based on a robust modular design with integrated shut-off valves (ball / seat chamfer). This modular design can be used as the basis for condensate collection / steam distribution manifolds with between 2 and 18 secondary connections (series ... -02 to series ...-18).

The valve is based on a hard-sealing (metal on metal) construction:

- body (Pos. 1) / screw fitting (Pos. 15)
- seat (Pos. 3) / body (Pos. 1)
- valve plug (Pos. 4) / seat (Pos. 3)
- safety back-sealing mechanism
  - CODI<sup>®</sup>S: spindle (Pos. 11) / screw fitting (Pos. 15)
  - CODI<sup>®</sup>B: spindle (Pos. 11) / spindle guide (Pos. 16)

There are also graphite rings (Pos. 5 / Pos. 10) which take over external sealing in the position between "OPEN" or "SHUT".



#### **ATTENTION !**

*Do not use shut-off valves for OPEN-SHUT function to throttle volume flow.*

#### **Valve position:**

**OPEN** - Safety back-sealing mechanism effective when valve fully open.

**SHUT** - Valve plug (Pos. 4) / chamfer at seat (Pos 3) seal effective.

#### 4.2.1 Condensate collection manifold

- Condensate enters secondary connection B (side)
- As a rule condensate is discharged at the top
- Secondary connections B are opened and shut by shut-off valves A

#### 4.2.2 Steam distribution manifolds

- Steam enters at top
- Steam is discharged through secondary connections B (side)
- **Secondary connections B are opened and shut by shut-off valves A**

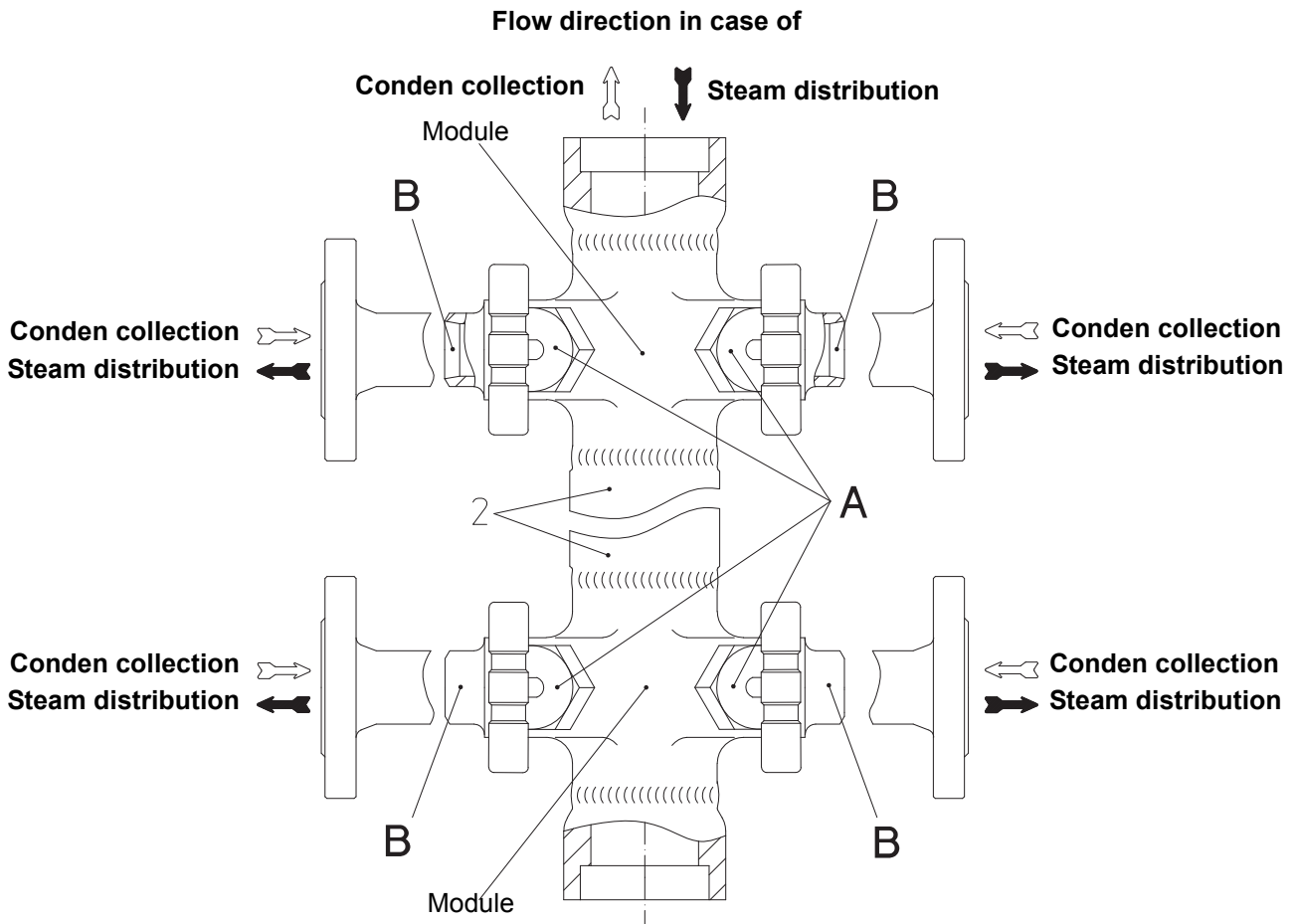

#### Fastening of manifolds for condensate collection / Steam distribution

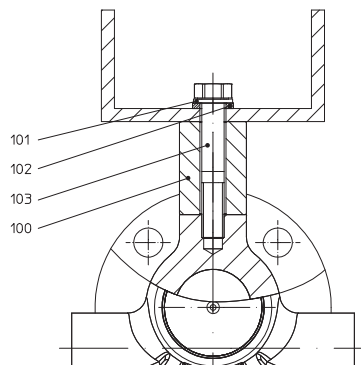

Fig. 1: Design CODI®

### 4.3 Diagram

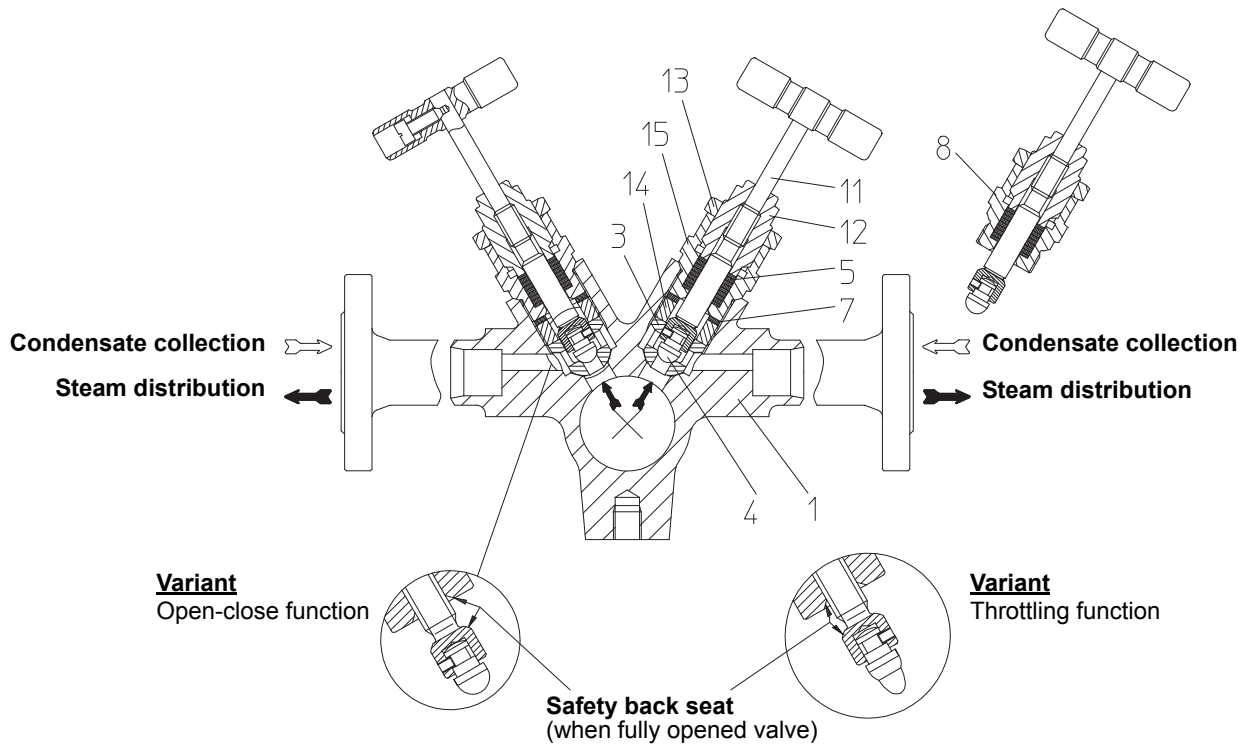

Fig. 2: CODI<sup>®</sup>S - series 671/672 PN40-63  
 primary connection DN25-50 / secondary connection DN15-25

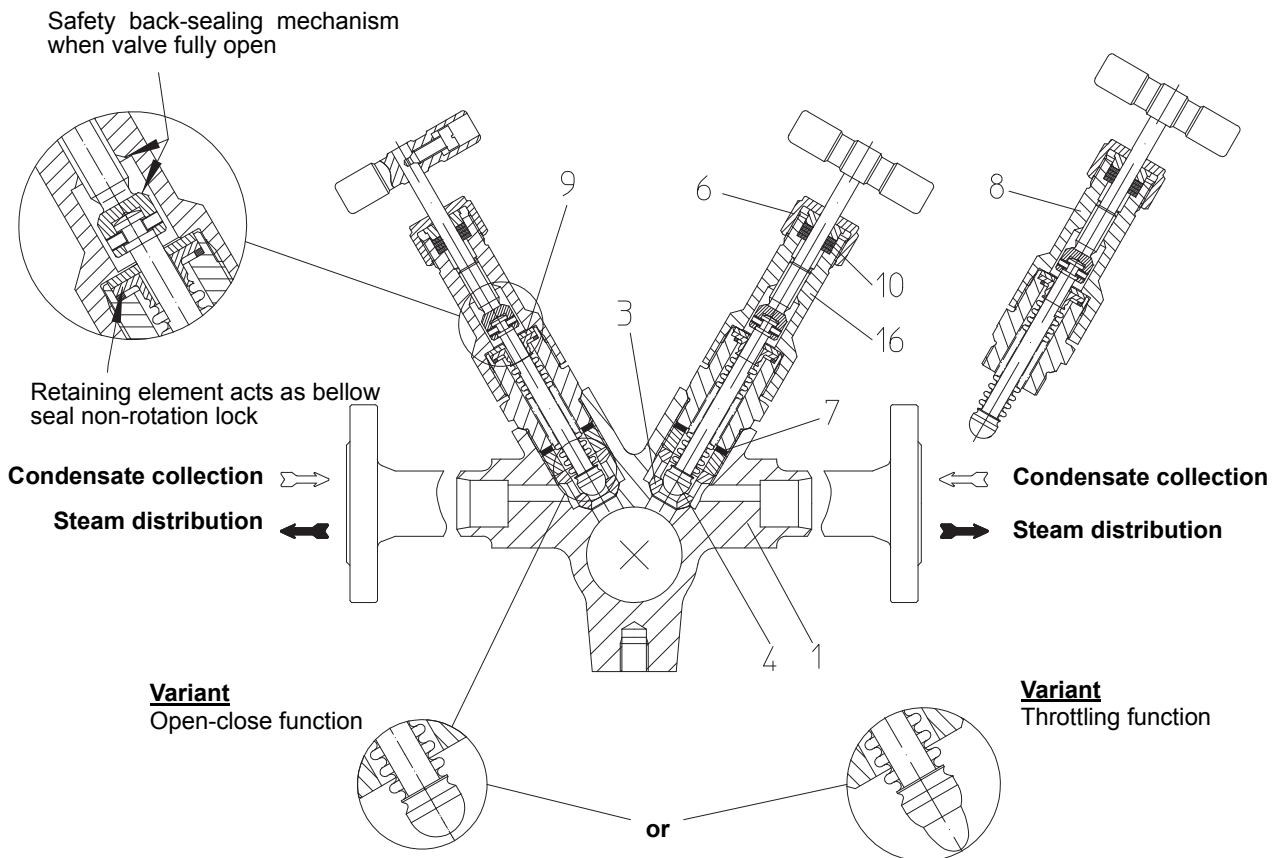

Fig. 3: CODI<sup>®</sup>B - series 675/676 PN40-63  
 primary connection DN25-50 / secondary connection DN15-25

Refer to the data sheet for information about materials with designations and figure numbers.

## 4.4 Technical data - remarks

for

- Principal dimensions,
- Pressure-temperature-ratings, operating limits,
- Valves with different types of connection , etc.  
refer to datasheet.

## 4.5 Marking

Details of the CE-marking on the valve:

 CE-marking

0045 Notified body

**AWH** Manufacturer

Anschrift des Herstellers:

siehe Pkt 11.0 Garantie / Gewährleistung

Typ Type

Bj. Year of manufacture

According to the Pressure Equipment Directive appendix 2 diagram 7 valves acc. to article 1 paragraph 2.1.2 (pipes) only show the CE-marking from DN40 onwards.

## 5.0 Installation

### 5.1 General notes on installation

The following points should be taken into account besides the general principles governing installation work:



#### **ATTENTION !**

- Remove flange covers if present.
- The interior of valve and pipeline must be free from foreign particles.
- Installation position vertical (series 671/675) or horizontal (series 672/676).  
Note installation position with reference to flow, see mark on valve.
- Steam line systems should be designed to prevent water accumulation.
- Lay pipelines so that damaging transverse, bending and torsional forces are avoided.
- Protect valves from dirt during construction work.
- Connection flanges must mate exactly.
- Valves must not be used to take external forces, e.g. they are not designed for use as climbing aids, or as connecting points for lifting gear.
- Suitable materials handling and lifting equipment should be used.  
See data sheet for weights.
- Centre gaskets between the flanges.
- Precautions against freezing should be taken as a matter of course in all facilities susceptible to frost.

- Planners / construction companies or operators are responsible for positioning and installing products.
- The valves are designed for application, not influenced from weather.
- For application outside or in adverse environments like corrosion-promoting conditions (sea water, chemical vapours, etc.), special constructions or protective measures are recommended.

## 5.2 Installation instructions for welding

(refer to Fig. 2 - Fig. 3 page 5)

Please note that only qualified persons using appropriate equipment and working in accordance with technical rules are allowed to install fittings by welding.

The responsibility for this lies with the system owner.

The integrated shut-off valves must be in the open position when carrying out welding work on the primary and secondary connections of the condensate collection / steam distribution manifolds. No further precautions are necessary against the effect of heat.

If there are plans to etch the facility before putting it into operation, the complete shut-off valve assembly (Pos. 8) should be removed, replaced by etch inserts, and refitted after etching (see 7.1). In such an event please contact the manufacturer.

## 5.3 Installation position

Series 671/675: vertical installation position

Series 672/676: horizontal installation position

Note installation position relative to flow, see mark on valve.

## 6.0 Putting the valve into operation



### **ATTENTION !**

- Before putting the valve into operation, check material, pressure, temperature and direction of flow.
- Regional safety instructions must be adhered to.
- Residues in piping and valves (dirt, weld beads, etc.) inevitably lead to leakage.
- Touching the valve when it is operating at high ( $> 50\text{ °C}$ ) or low ( $< 0\text{ °C}$ ) media temperatures can cause injury.

*Affix warning notice or protective insulation as appropriate!*

*Before putting a new plant into operation or restarting a plant after repairs or modification, always make sure that:*

- All works has been completed!
- The valve is in the correct position for its function.
- Safety devices have been attached.

## 7.0 Care and maintenance

Maintenance and maintenance-intervals have to be defined by the operator according to the requirements.



### **ATTENTION !**

- refer to item 10.0 and 11.0 prior to dismantling and repair work!
- refer to item 6.0 before restarting the plant !

*Prior to installation, threads and seal faces should be coated with temperature-stable lubricant (e.g. "OKS Anti-Seize Paste" white/metal-free for PN 16-40 or "Rivolta" lubricant and parting agent silver for PN 63 onwards).*

### 7.1 Disassembling/assembling complete shut-off valve assembly

(see Fig. 2 page 5 - Fig. 3 page 5)

- Open spindle (Pos. 11) fully as far as the stop.
- Unscrew shut-off valve assembly (Pos. 8) from body (Pos. 1) by rotating to the left.
- Remove graphite insert (Pos. 7).
- Unscrew hollow-core screw (Pos. 14) using AWH assembly spanner.
- Remove seat (Pos. 3).
- Assemble in reverse order (see 7.5).

### 7.2 Replacing the packing rings (CODI<sup>®</sup>S)

- Dismantle shut-off valve assembly (Pos. 8) as described in 7.1.



### **ATTENTION !**

*It is vital to avoid damage to spindle surface and packing chamber surface.*

- Rotate spindle (Pos. 11) in closing direction.
- Slacken cheese-head screw (Pos. 18).
- Pull handle (Pos. 19) away from spindle (Pos. 11).
- Release lock nut (Pos. 13).
- Unscrew threaded bush (Pos. 12).
- Withdraw spindle (Pos. 11) downwards from threaded bush (Pos. 12).
- Dismantle cover ring (Pos. 20) and packing rings (Pos. 5).
- Clean packing chamber and spindle surface.
- Push spindle (Pos. 11) into screw fitting (Pos. 15) and fit new packing rings (Pos. 5).
- Assemble in reverse order (see 7.5).

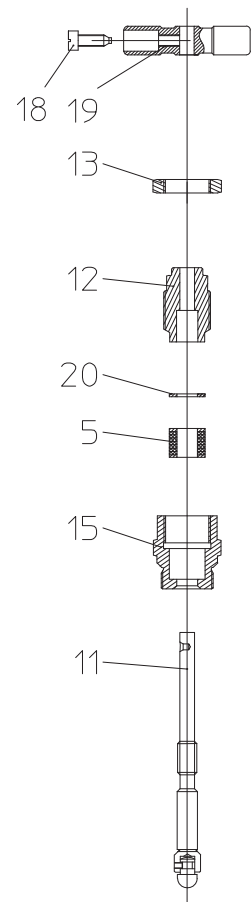



Fig. 4



### 7.3 Replacing packing rings of the secondary sealing gland packing (CODI<sup>®</sup>B)

- Dismantle shut-off valve assembly (Pos. 8) as described in 7.1.

	<p><b>ATTENTION !</b>  <i>It is vital to avoid damage to spindle surface and packing chamber surface.</i></p>
---	---

- Rotate spindle (Pos. 11) in closing direction.
- Slacken cheese-head screw (Pos. 18).
- Pull handle (Pos. 19) away from spindle (Pos. 11).
- Unscrew sleeve nut (Pos. 6).
- Remove pressure plate (Pos. 21).
- Unscrew spindle guide (Pos. 16) from screw fitting (Pos. 15) and withdraw from spindle (Pos. 11).
- Dismantle packing rings (Pos. 10).
- Clean packing chamber and spindle surface.
- Push spindle (Pos. 11) into spindle guide (Pos. 16) and fit new packing rings (Pos. 10).
- Assemble in reverse order (see 7.5).

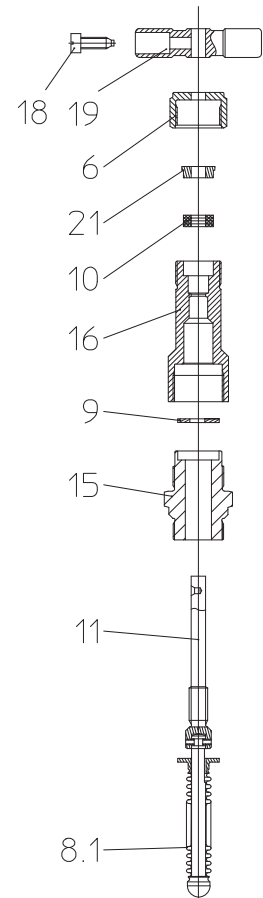

Fig. 5

### 7.4 Insulating jacket option

- With the CODI® already fixed to the carrier structure, push base insulation (Fig. 6) between body (Pos. 1) and carrier structure.
- Lay sides of base insulation around body (Pos. 1).
- Close Velcro fastener.
- Check proper fit of insulating jacket and align if necessary.
- Push outer jacket (Fig. 7) between carrier structure and CODI® fitted with base insulation.
- Lay sides of outer jacket around body (Pos. 1) with base insulation fitted.
- Close Velcro fastener.
- Close strap fasteners.
- Check proper fit of outer jacket and align if necessary.

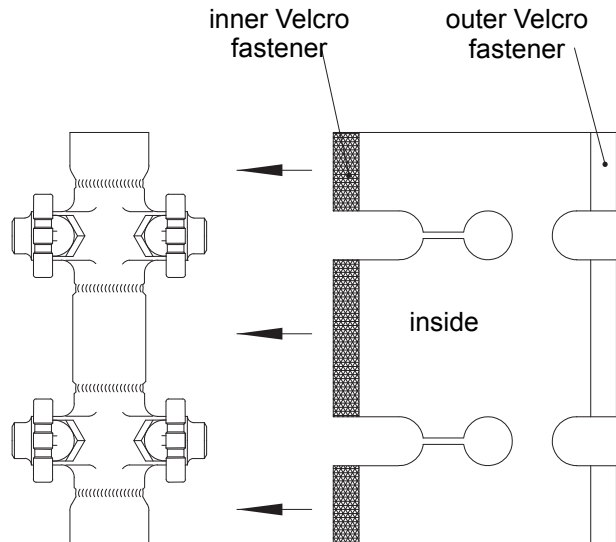

Fig. 6: Base insulation

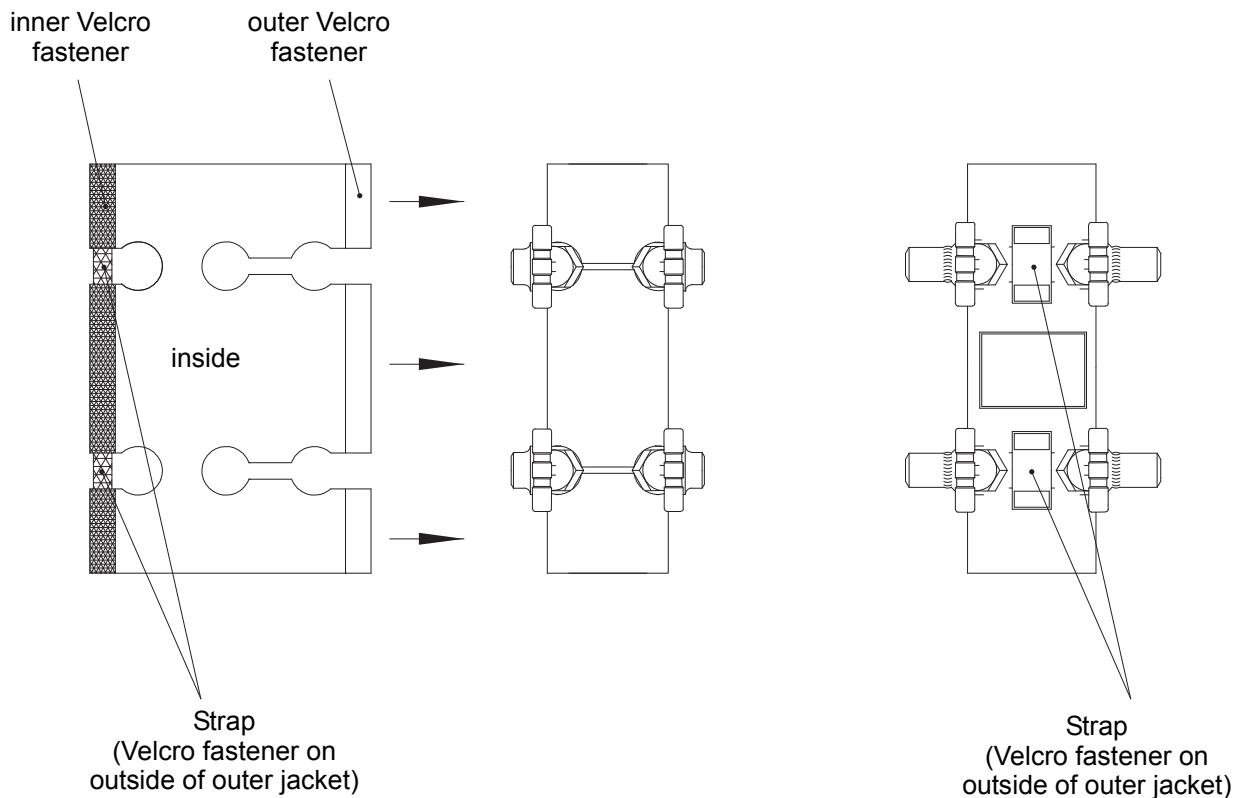

Fig. 7: Outer jacket

## 7.5 Tightening torques

(refer to Fig. 2 page 5 - Fig. 5 page 9)

Pos.	CODI S / B	Torque (Nm)
6	Sleeve nut	10
12	Threaded bush	10
13	Safety nut	70
14	Banjo bolt	70
15	Fitting	90
16	Stem guiding	90

## 8.0 Troubleshooting

In the event of malfunction or faulty operating performance check that the installation and adjustment work has been carried out and completed in accordance with these Operating Instructions.



**ATTENTION !**  
It is essential that the safety regulations are observed when identifying faults.

If malfunctions cannot be eliminated with the help of the following table "9.0 troubleshooting table", the supplier or manufacturer should be consulted.

## 9.0 Troubleshooting table



**ATTENTION !**  
- refer to item 10.0 and 11.0 prior to dismantling and repair work!  
- refer to item 6.0 before restarting the plant !

Fault	Possible cause	Corrective measures
No flow	Installed in wrong flow direction.	Fit valve in direction of flow arrow
	Flange covers not removed	Remove flange covers
Little flow	Piping system clogged	Check piping system
No closure, or internal leakage	Shut-off valve clogged	Clean shut-off valve; refer to item 7.1
	Shut-off valve worn	Replace shut-off valve; refer to item 7.1
	Shut-off valve operated above safe operating pressure	Observe operating limits as per data sheet
External leakage	Shut-off valve not properly tightened	Tighten; see 7.5
	Seal (Pos. 5, 10) defective	Replace sealing; refer to item 7.2 and 7.3

## 10.0 Dismantling the valve or the body



### **ATTENTION !**

*The following points must be observed:*

- *Pressureless pipe system.*
- *Medium must be cool.*
- *Plant must be drained.*

## 11.0 Warranty / Guarantee

The extent and period of warranty cover are specified in the "Standard Terms and Conditions of Albert Richter GmbH & Co. KG" valid at the time of delivery or, by way of departure, in the contract of sale itself.

We guarantee freedom of faults in compliance with state-of-the-art technology and the confirmed application.

No warranty claims can be made for any damage caused as the result of incorrect handling or disregard of operating and installation instructions, datasheets and relevant regulations.

This warranty also does not cover any damage which occurs during operation under conditions deviating from those laid down by specifications or other agreements.

Justified complaints will be eliminated by repair carried out by us or by a specialist appointed by us.

No claims will be accepted beyond the scope of this warranty. The right to replacement delivery is excluded.

The warranty shall not cover maintenance work, installation of external parts, design modifications or natural wear.

Any damage incurred during transport should not be reported to us but *rather* to the competent cargo-handling depot, the railway company or carrier company immediately or else claims for replacements from these companies will be invalidated.



**Technology for the Future.**

**GERMAN QUALITY VALVES**

ARI-Armaturen Albert Richter GmbH & Co. KG, D-33756 Schloß Holte-Stukenbrock

Telephone (+49 5207) 994-0 Telefax (+49 5207) 994-158 or 159

Internet: <http://www.ari-armaturen.com> E-mail: [info.vertrieb@ari-armaturen.com](mailto:info.vertrieb@ari-armaturen.com)