

# Operating and installation instructions

## Stop valve with soft seal EURO-WEDI®

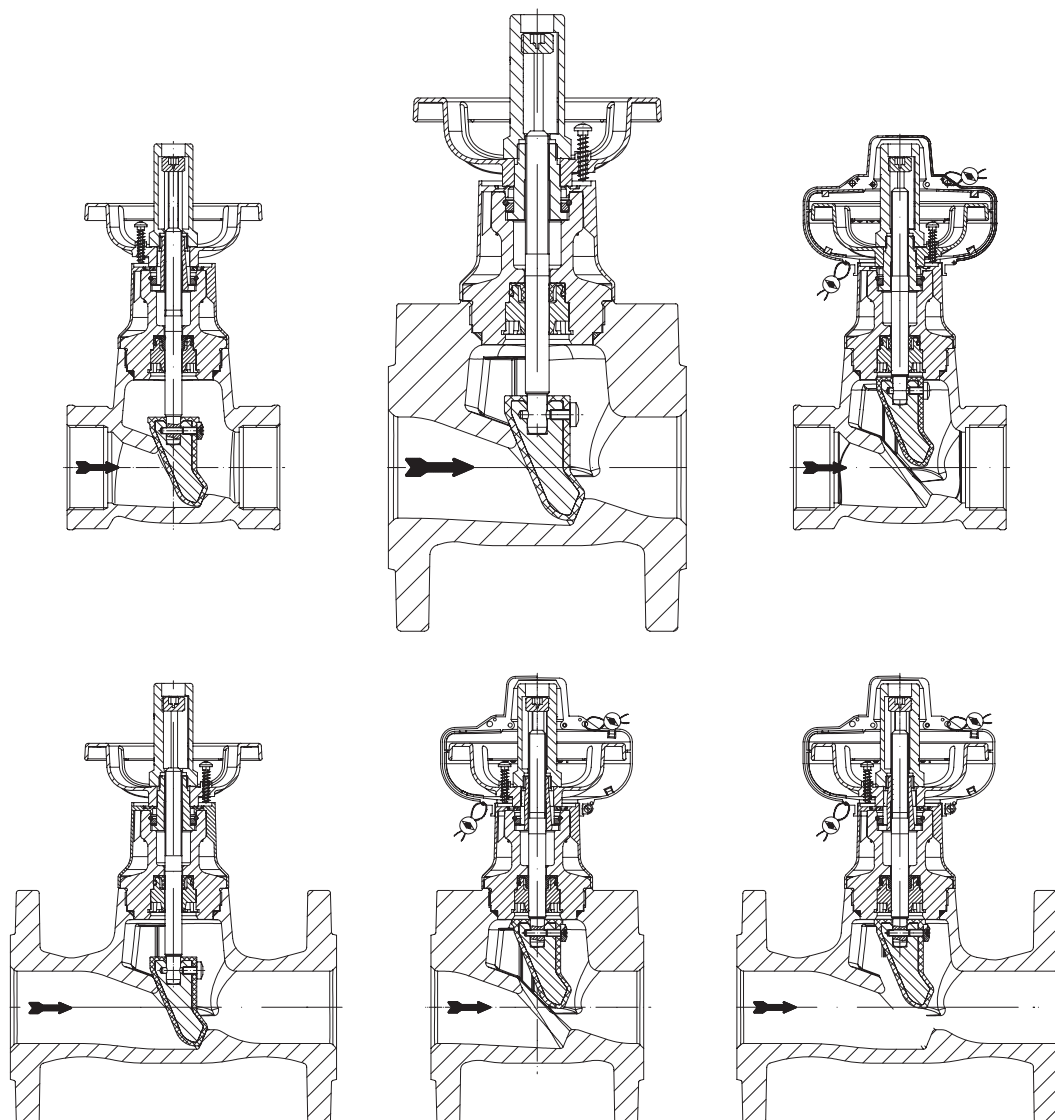

### Contents

<b>1.0 General information on operating instructions</b> .....	<b>2-2</b>	<b>7.0 Care and maintenance</b> .....	<b>2-7</b>
<b>2.0 Notes on possible dangers</b> .....	<b>2-2</b>	7.1 Hood valve .....	2-7
2.1 Significance of symbols .....	2-2	<b>8.0 Troubleshooting</b> .....	<b>2-8</b>
2.2 Explanatory notes on safety information .....	2-2	<b>9.0 Troubleshooting table</b> .....	<b>2-8</b>
<b>3.0 Storage and transport</b> .....	<b>2-2</b>	<b>10.0 Dismantling the valve or the top part</b> ....	<b>2-9</b>
<b>4.0 Description</b> .....	<b>2-3</b>	<b>11.0 Warranty / Guarantee</b> .....	<b>2-9</b>
4.1 Scope of applications .....	2-3	<b>12.0 EC declaration of conformity</b> .....	<b>2-10</b>
4.2 Operating principles .....	2-3		
4.3 Diagram .....	2-4		
4.4 Technical data - remarks .....	2-5		
4.5 Marking .....	2-5		
<b>5.0 Installation</b> .....	<b>2-5</b>		
5.1 General notes on installation .....	2-5		
<b>6.0 Putting the valve into operation</b> .....	<b>2-6</b>		

## 1.0 General information on operating instructions

These operating instructions provide information on mounting and maintaining the fittings. Please contact the supplier or the manufacturer in case of problems which cannot be solved by reference to the operating instructions.

They are binding on the transport, storage, installation, start-up, operation, maintenance and repair.

The notes and warnings must be observed and adhered to.

- Handling and all work must be carried out by expert personnel or all activities must be supervised and checked.

It is the owner's responsibility to define areas of responsibility and competence and to monitor the personnel.

- In addition, current regional safety requirements must be applied and observed when taking the fittings out of service as well as when maintaining and repairing them.

The manufacturer reserves the right to introduce technical modifications at any time.

These Operating Instructions comply with the requirements of EU Directives.

## 2.0 Notes on possible dangers

### 2.1 Significance of symbols



Warning of general danger.

### 2.2 Explanatory notes on safety information

In these Operating and Installation Instructions dangers, risks and items of safety information are highlighted to attract special attention.

Information marked with the above symbol and "**ATTENTION!**" describe practices, a failure to comply with which can result in serious injury or danger of death for users or third parties or in material damage to the system or the environment. It is vital to comply with these practices and to monitor compliance.

All other information not specifically emphasised such as transport, installation, operating and maintenance instructions as well as technical data (in the operating instructions, product documentation and on the device itself) must also be complied with to the fullest extent in order to avoid faults which in turn can cause serious injury to persons or damage to property.

## 3.0 Storage and transport

	<p><b>ATTENTION !</b></p> <ul style="list-style-type: none"><li>- <i>Protect against external force (like impact, vibration, etc.).</i></li><li>- <i>Valve mountings such as actuators, handwheels, hoods must not be used to take external forces, e.g. they are not designed for use as climbing aids, or as connecting points for lifting gear.</i></li><li>- <i>Suitable materials handling and lifting equipment should be used.</i></li></ul> <p><i>See catalog sheet for weights.</i></p>
-------------------------------------------------------------------------------------	--------------------------------------------------------------------------------------------------------------------------------------------------------------------------------------------------------------------------------------------------------------------------------------------------------------------------------------------------------------------------------------------------------------------------------------------------------------------------------------------------

- At -20°C to +65°C.

- The paint is a base coat to protect against corrosion during transportation and storage. Do not damage paint protection.

## 4.0 Description

### 4.1 Scope of applications

Valves are used for „shut-off and/or throttling of media“.



#### **ATTENTION !**

- Refer to the data sheet for applications, limits on use and possibilities.
- Certain media require or preclude the use of special materials.
- The valves are designed for standard operating conditions. If conditions exceed these requirements, e.g. aggressive or abrasive media, the operator should state the higher requirements when ordering.
- Valves made from grey cast iron are not authorised for use in systems subject to TRD 110.

The information complies to the Pressure Equipment Directive 97/23/EC.

It is the responsibility of the machine planner to ensure compliance.

The special markings on the valve must be taken into account.

Refer to the catalogue sheet to see which materials are used in standard versions.

Please contact the supplier or the manufacturer if you have any questions.

EURO-WEDI-hood valves for protection of unauthorized closure, are used corresponding to DIN EN 12828.

Don't use EURO-WEDI valves for the medium steam!

### 4.2 Operating principles

The valve is closed by turning the hand wheel clockwise (plug/seat function).



#### **ATTENTION !**

*Do not use tools to increase the torque on the hand wheel.*

The valve stem is sealed by an elastomer sealing system (DN15-150) resp. EDD-Special stem seal (DN200).

With a fully open valve relieves the back seat of the elastomer sealing system.

From DN65 upwards, the lift limitation nut has to be removed and then the valve have to be opened completely.

EURO-WEDI seals in the "open" state are protected against accidental closing by a protective cap.

**4.3 Diagram**

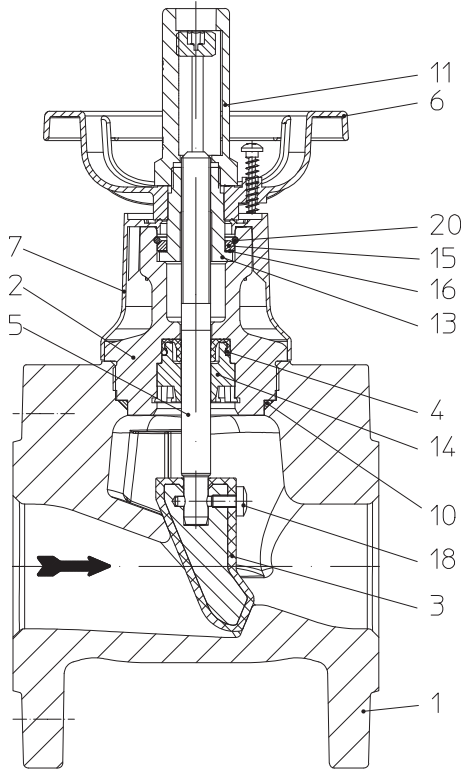

**Fig. 1: EURO-WEDI length FTF-14**

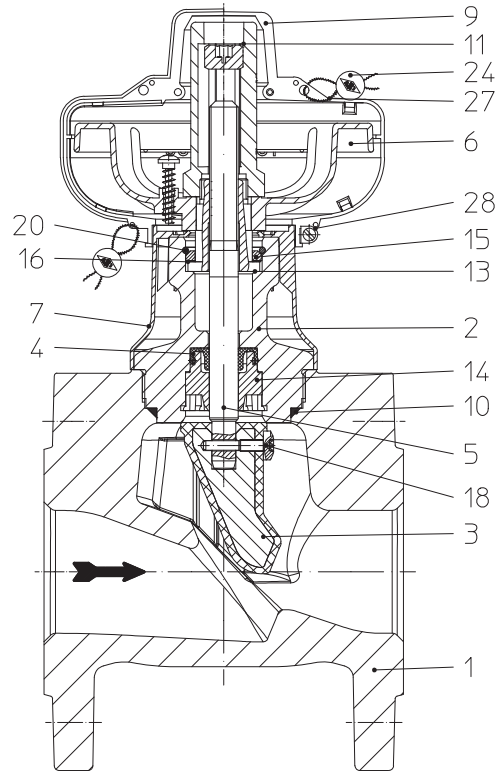

**Fig. 2: EURO-WEDI length FTF-14 hood valve**

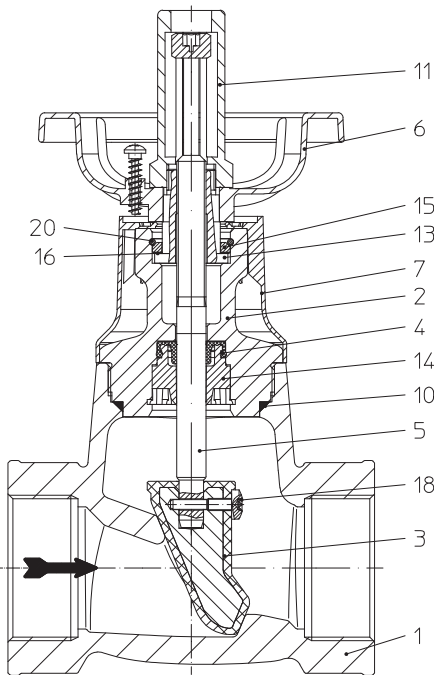

**Fig. 3: EURO-WEDI length FTF-14 screwed socket connection**

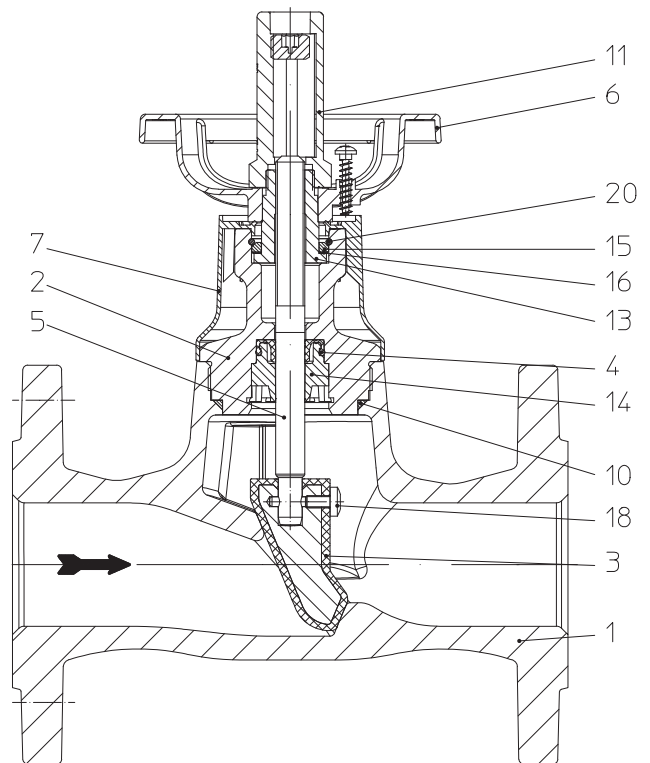

**Fig. 4: EURO-WEDI length FTF-1**

Refer to the data sheet for information about materials with designations and figure numbers.

## 4.4 Technical data - remarks

for

- **Principal dimensions**
- **Pressure-temperature-ratings, etc.** refer to datasheet.

## 4.5 Marking

Details of the CE-marking on the valve:

 CE-marking

0525 Notified body



Manufacturer

Address of manufacturer:

refer to item 11.0 Warranty / Guarantee

Typ Type

Bj. Year of manufacture

According to the Pressure Equipment Directive table 6, annex II, valves without safety function are only allowed to bear the CE-marking DN32 onwards.

## 5.0 Installation

### 5.1 General notes on installation

The following points should be taken into account besides the general principles governing installation work:



#### **ATTENTION !**

- *Remove flange covers if present.*
- *The interior of valve and pipeline must be free from foreign particles.*
- *Note installation position with reference to flow, see mark on valve.*
- *Steam line systems should be designed to prevent water accumulation.*
- *Lay pipelines so that damaging transverse, bending and torsional forces are avoided.*
- *Protect valves from dirt during construction work.*
- *Connection flanges must mate exactly.*
- *Connecting bolts for pipe flanges should be mounted preferably from the counter flange side (hexagon nuts from the valve side).*  
*At DN15-32: If valves should be mounted directly to valves, the upper flange connecting bolts should be preferably executed with studs and hexagon nuts on both sides.*
- *Valve mountings such as actuators, handwheels, hoods must not be used to take external forces, e.g. they are not designed for use as climbing aids, or as connecting points for lifting gear.*
- *Suitable materials handling and lifting equipment should be used.*  
*See data sheet for weights.*
- *Valves can be installed with the stem pointing in any direction, but the preferred stem position is vertical.*
- *Valves should be installed upside down only, if the medium being handled is clean.*

- Centre gaskets between the flanges.
- Reference for isolation: If media-temperatures < ambient temperatures - ask manufacturer.
- It is forbidden to heat the valve to above its service temperature (see data sheets), for instance by welding, grinding, etc.

- Planners / construction companies or operators are responsible for positioning and installing products.
- The valves are designed for application, not influenced from weather.
- For application outside or in adverse environments like corrosion-promoting conditions (sea water, chemical vapours, etc.), special constructions or protective measures are recommended.

## 6.0 Putting the valve into operation



### **ATTENTION !**

- Before putting the valve into operation, check material, pressure, temperature and direction of flow.
- Regional safety instructions must be adhered to.
- Residues in piping and valves (dirt, weld beads, etc.) inevitably lead to leakage.
- Touching the valve when it is operating at high (> 50°C) or low (< 0°C) media temperatures can cause injury.  
Affix warning notice or protective insulation as appropriate!

Before putting a new plant into operation or restarting a plant after repairs or modification, always make sure that:

- All works has been completed!
- The valve is in the correct position for its function.
- Safety devices have been attached.

## 7.0 Care and maintenance

Maintenance and maintenance-intervals have to be defined by the operator according to the requirements.

- Keep the stem well greased!
- Lubricant: e.g. Berulub HYDROHAF 2  
to order at: CARL BECHEM GmbH, Weststraße 120, D-58089 Hagen  
or a lubricant which is suitable for the application.



**ATTENTION !**  
Pay attention, that the lubricant is suitable for the media.

### 7.1 Hood valve

- Remove the protective caps of hood valves to open/ close the valve.
- Remove the plastic seal and seal wires.
- DN80-200: Force out two GETO split rivets (force part 2 out and extract part 1).
- Slacken the clamp screw and extract the clamp from the guide in the hood.
- Force the half hoods covering the hand wheel apart and remove them.
- Slacken the cutting screw.
- Close the EURO-WEDI by turning the hand wheel.
- Reassemble the parts in the reverse order.

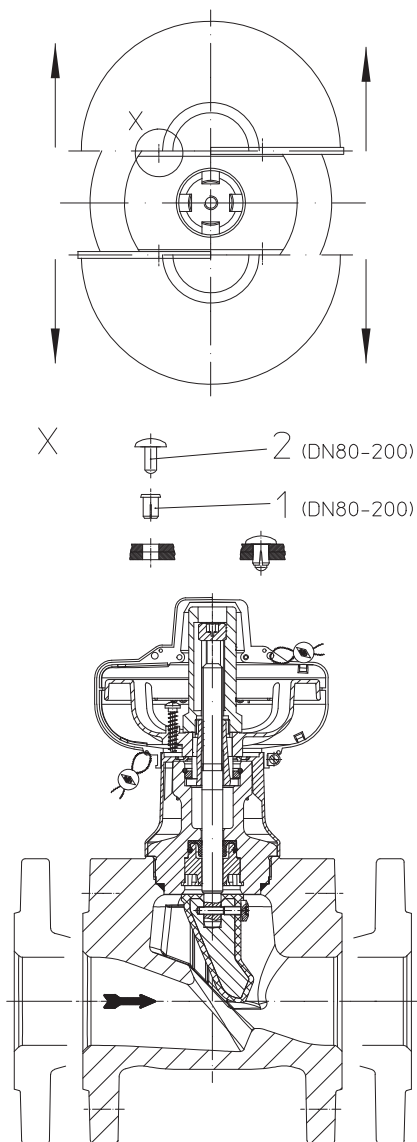



Fig. 5

## 8.0 Troubleshooting

In the event of malfunction or faulty operating performance check that the installation and adjustment work has been carried out and completed in accordance with these Operating Instructions.

	<p><b>ATTENTION !</b></p> <p>It is essential that the safety regulations are observed when identifying faults.</p>
-----------------------------------------------------------------------------------	--------------------------------------------------------------------------------------------------------------------

If malfunctions cannot be eliminated with the help of the following table "9.0 Troubleshooting table", the supplier or manufacturer should be consulted.

## 9.0 Troubleshooting table

	<p><b>ATTENTION !</b></p> <p>- read point 10.0 and 11.0 prior to dismantling and repair work! - read point 6.0 before restarting the plant !</p>
-----------------------------------------------------------------------------------	------------------------------------------------------------------------------------------------------------------------------------------------------

Fault	Possible cause	Corrective measures
No flow	Valve closed.	Open valve.
	Flange covers not removed.	Remove flange covers.
Little flow	Valve not sufficiently open.	Open valve.
	Dirt sieve clogged.	Clean / replace sieve.
	Piping system clogged.	Check piping system.
Valve difficult to move or cannot be opened	Wrong direction of rotation	Turn in correct direction (anticlockwise to open valve).
Valve stem leaking	Damage to the sealing system	Open valve fully, so that the back seat of the plug relieves the sealing system
		Replace valve or bonnet.
Leakage across valve seat.	Valve not properly closed.	Pull hand wheel tight without tools.
	Seat (1) / plug (3) damaged by foreign particles. (Fig. 1-4).	Replace valve, consult supplier/manufacturer.
	Pressure difference too high.	Check system pressure and pressure drop (max. $\Delta p = 16$ bar). Reduce system pressure.
	Medium contaminated (suspended solids).	Clean valve. Install dirt screen upstream of valve.
Valve cannot be opened.	Travel limiter on stem stop has been tightened. Locking device has been tightened.	Turn travel limiter upwards. Slacken the locking device.
Flange broken between valve and piping.	Bolts tightened unevenly. Mating flanges not properly aligned.	Re-align piping and fit new valve!



## 10.0 Dismantling the valve or the top part



### **ATTENTION !**

*The following points must be observed:*

- *Pressureless pipe system.*
- *Medium must be cool.*
- *Plant must be drained.*
- *Purge piping systems in case of caustic, inflammable, aggressive or toxic media.*

## 11.0 Warranty / Guarantee

The extent and period of warranty cover are specified in the "Standard Terms and Conditions of Albert Richter GmbH & Co. KG" valid at the time of delivery or, by way of departure, in the contract of sale itself.

We guarantee freedom of faults in compliance with state-of-the-art technology and the confirmed application.

No warranty claims can be made for any damage caused as the result of incorrect handling or disregard of operating and installation instructions, datasheets and relevant regulations.

This warranty also does not cover any damage which occurs during operation under conditions deviating from those laid down by specifications or other agreements.

Justified complaints will be eliminated by repair carried out by us or by a specialist appointed by us.

No claims will be accepted beyond the scope of this warranty. The right to replacement delivery is excluded.

The warranty shall not cover maintenance work, installation of external parts, design modifications or natural wear.

Any damage incurred during transport should not be reported to us but *rather* to the competent cargo-handling depot, the railway company or carrier company immediately or else claims for replacements from these companies will be invalidated.



**Technology for the Future.**

**GERMAN QUALITY VALVES**

ARI-Armaturen Albert Richter GmbH & Co. KG, D-33756 Schloß Holte-Stukenbrock

Telephone (+49 5207) 994-0 Telefax (+49 5207) 994-158 or 159

Internet: <http://www.ari-armaturen.com> E-mail: [info.vertrieb@ari-armaturen.com](mailto:info.vertrieb@ari-armaturen.com)

## 12.0 EC declaration of conformity

ARI-Armaturen Albert Richter GmbH & Co. KG,  
Mergelheide 56-60, D-33756 Schloß Holte-Stukenbrock

**EC declaration of conformity**  
as defined by  
the Pressure Equipment Directive 97/23/EC

Herewith we declare,

that according to the above mentioned Pressure Equipment Directive (PED) the below listed products comply and have been approved according to table 6, annex II, module H through Lloyd's Register Quality Assurance GmbH (BS-Nr. 0525), Am Sandtorkai 41, D-20457 Hamburg.

Certificate-No: 50003/1

**Stop valves with soft seal**  
**EURO WEDI®**  
**Type 070, 071, 072, 073, 076, 078**

Applied standards:  
DIN 3840

Schloß Holte-Stukenbrock, 11.01.2010

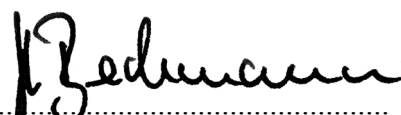
  
.....  
(Brechmann, Managing director)