



CSA products for treated water

**Water Combination air valve**

Mod. Lynx 3F RFP

---

## Instructions

These instructions provide installation, operation and maintenance information for CSA water combination air valves model Lynx 3F RFP. They are for use by personnel who are responsible for installation, operation and maintenance of CSA air/vacuum release valves.

## Safety Messages

All safety messages in the instructions are flagged with an exclamation symbol and the word Caution, Warning or Danger. These messages indicate procedures that must be followed exactly to avoid equipment damage, personal injury or death. Safety label(s) on the product indicate hazards that can cause equipment damage, personal injury or death.

If a safety sign or symbol becomes difficult to see or read, please contact us.



### **WARNING!**

**Personnel involved in the installation or maintenance of valves should be constantly alert to potential emission of pipeline material and take appropriate safety precautions. Always wear suitable protection when dealing with hazardous pipeline materials. Handle valves, which have been removed from service, with suitable protection for any potential pipeline material in the valve.**

## Inspection

Your CSA combination air valve has been packaged to provide protection during shipment; however, it can be damaged in transport. Carefully inspect the unit for damage upon arrival and file a claim with the carrier if damage is apparent.

## Parts

Recommended spare parts are listed on the assembly drawing. These parts should be stocked to minimize downtime. When ordering parts, please include the model, type and numbers located on the data plate placed on the valve. Also include the part name, the assembly drawing number, and the quantity stated on the assembly drawing.

## Table of Contents

Description - - - - -	4
Handling and Storage - - - - -	4
Installation - - - - -	4
Fusion/Powder Coated Valves - - - - -	5
Maintenance - - - - -	5
<i>Disassembly Procedure (Air/Vacuum Valve)</i> - - - - -	5
<i>Assembly Procedure (Air/Vacuum Valve)</i> - - - - -	6
Drawing - - - - -	6
Troubleshooting - - - - -	7

## Description

The CSA Lynx 3F RFP water combination air valve are designed to release air pockets in working conditions, to allow the entrance or large volumes of air during pipe draining, or burst, and the controlled discharge, in case of excessive outflow air speed, to prevent water hammer events in case of rapid pipeline filling and transients following pump failures.

This type of air valve should not be considered as relief for shock conditions and upsurges which develop elsewhere in the system, for which other and different CSA models and solutions are available.

The maximum and minimum pressure are stated in the order and according to technical literature. In general we recommend to ensure at least 0,35 bar acting on the air valve to ensure the perfect sealing during working conditions.

## Handling and Storage

Lifting the valve improperly may damage it. Lift the valve with slings, chains or cables fastened around the valve body, or eyebolts on the cap if present, or fastened to bolts or rods through bolt holes in the flanges.

If installation will be delayed, place valve indoors in secure, weather tight storage. If temporary outside storage is unavoidable, make sure a vermin proof rain cover is secured around/over the valve to keep off rain and mud. Skid and set the assembly on a flat, solid, and well drained surface for protection from ground moisture, runoff and pooled rain water. Do not leave the valve exposed to high humidity and excessive temperature conditions.

## Installation

The rapid filling prevention water combination air valve should always be installed in a vertical position. An isolation valve between this unit and the transmission (pipeline) system is necessary to allow maintenance and valve's inspection. Where to use:

- high points in pipelines where the hydraulic gradient and flow conditions are such that a negative pressure can possibly occur;
- change in slope descending and ascending (for the latter air vacuum models are normally enough).
- This model **should not be** placed adjacent to any pumps, quick closing valve in a pipeline such as a check or gate valve where vacuum and column separation can occur upon closure. For such cases the CSA air valves anti surge model Lynx 3F AS are suitable.

**Note to Engineer:** If the air valve is to be installed inside a pump house, use threaded or outlet flanged connections and pipe back into the well or to outside obtained by CSA SUB kit. This will greatly muffle the high noise level caused by the air being discharged and provide for drainage of any small amount of water or water vapour that may accumulate. Same thing applies in case of possible flood events to the installation chamber to avoid the entrance of polluted water

- Before installation, remove foreign material such as weld spatter, oil, grease, and dirt from the pipeline.
- Prepare pipe ends and install valves in accordance with the pipe manufacture's instructions for the joint used.

- Tighten the flange bolts or studs in a crisscross pattern and minimum of four stages.

### Fusion/Powder Coated Valves



#### **CAUTION!**

**Valves with fusion/powder coated exterior paint require flat washers to be installed under the flange nuts when installing the valve to the pipeline flange to prevent the paint from cracking or chipping.**

### Maintenance

The combination air valve is automatic in operation and requires very little maintenance. It should always be installed in a vertical position with a maximum tilt within 3°.

A semi-annual visual inspection for leakage is recommended. A malfunction of the air valve can be identified by the seepage of water through the air release nozzle and/or through the main seat. Should a malfunction occur, the following steps should be taken to repair the valve.

#### *Disassembly Procedure*

See Figures 1 on page 6 for part identification.



#### **WARNING!**

**Servicing the air/vacuum valve while the pipeline is under pressure can cause personal injury or equipment damage. Relieve pipeline pressure or shut off isolation valve before servicing the air/vacuum valve.**

1. Relieve pipeline pressure or shut off isolation valve before servicing the air valve.
2. Slowly remove the drain port (16) to relieve internal pressure.
3. Remove cover nuts (10), cover (2), screen (17) and spacers (11).



#### **WARNING!**

**When removing the screen be aware of sharp edges, use protective gloves and exert care during handling.**

4. Remove seat nuts (12), washers (13) and extract the seat (5).
5. Inspect sealing surface of the seat and check whether gaskets (3) and (4) are torn or damaged.
6. Pull out the RFP flat (6).
7. Inspect the upper surface for possible debris and accumulation of dirt and the lower surface checking whether the gasket (18) is torn or damaged .
8. Extract the mobile block composed of the upper flat (7) and lower float (8) joined together by the nozzle subset (19).
9. Inspect the nozzle subset or air release system (19) , clean it with some water and replace it if needed .

# CSA air valve Lynx 3F RFP

10. Do not try to pull apart the nozzle subset (19) without the support of our personnel.
11. Check to see if foreign matter or dirt is preventing float (8) from seating properly on the deflector (14). Clean as necessary.
12. Inspect all connections of linkage for excessive wear.
13. Clean all surfaces before re-assembly.

## Assembly Procedure

See Figures 1 for part identification.

Install the parts inside the body (1) in the following order:

- a. mobile block composed of the lower float (8) and upper flat (7) joined together by the air release mechanism (19),
- b. RFP flat (6),
- c. seat (5),
- d. tighten seat retaining nuts and washers (12 and 13),
- e. spacers (11), screen (17) and cover (2),
- f. tighten cap retaining nuts (10).

## Drawing

Figure 1

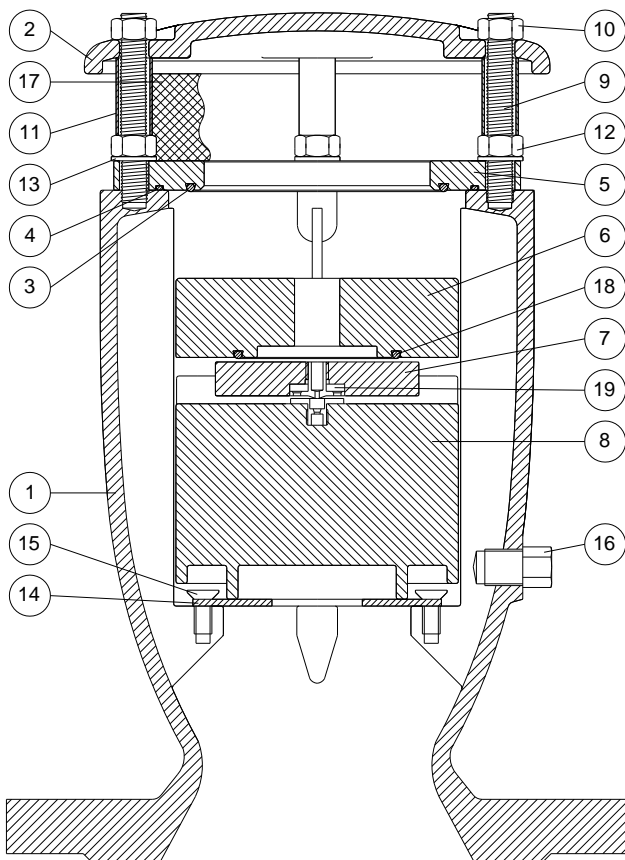

N.	Component	Material
1	Body	GJS 500-7/GJS 450-10
2	Cap	GJS 500-7/GJS 450-10
3	O-ring	NBR/EPDM/Viton/Silicone
4	O-ring	NBR/EPDM/Viton/Silicone
5	Seat	AISI 304/AISI 316
6	RFP flat	Polypropylene
7	Upper flat	Polypropylene
8	Float	Polypropylene
9	Studs	AISI 304/AISI 316
10	Nuts	AISI 304/AISI 316
11	Spacers	AISI 304/AISI 316
12	Nuts	AISI 304/AISI 316
13	Washers	AISI 304/AISI 316
14	Deflector	AISI 304/AISI 316
15	Screws	AISI 304/AISI 316
16	Drain valve	AISI 303/AISI 316
17	Screen	AISI 304
18	O-ring	NBR/EPDM/Viton/Silicone
19	Nozzle subset	AISI 316

Spare parts: 3-4-6-7-8-18-19

## Troubleshooting (ref. picture 1 on page 6)

Condition	Possible Cause	Corrective Action
Valve leaks at flange joint.	Loose flange bolting.	Tighten flange bolting.
	Blown flange gasket.	Replace flange gasket.
	Miss-alignment or damage to field piping and supports.	Adjust miss-alignment or repair piping or supports.
	Damaged flange face or improper flange connections.	Repair flange, replace valve body or adjust flange connections.
Valve leaks out of the main sealing seat (5).	Valve is not vertical	Place the valve in a vertical position with a max tolerance of 3°.
	Possible corrosion through the body and seat.	Check the fluid chemicals parameters and contact us.
	Dirt accumulated on the seat or ring (3) or the RFP flat (6).	Clean seat (5), o-ring (3) and flat (6).
	Worn seat or float.	Replace seat or float.
	Line pressure is under 0,3 bar .	Replace seat with softer sealing o-rings and contact us for further assistance.
	Worn o-ring between seat and body (4) .	Inspect and replace o-ring (4).
Valve leaks out of the air release subset (6)	Valve is not vertical.	Place the valve in a vertical position with a max tolerance of 3°.
	Possible corrosion through the nozzle and air release sealing system .	Check the fluid chemicals parameters and contact us.
	Dirt accumulated on the air release subset (19).	Inspect and clean the air release subset (19), replace if necessary.
	Line pressure is extremely low (below 0,2 bar).	Contact us for further assistance.

### Note to the engineer:

Further leakage through the body (1) may only happen in case of acids and corrosive fluid or environment to which air valve would be improperly exposed.

Leakage through the drain valve (16) may only happen in case of acids and corrosive fluid or environment to which Lynx RFP would be improperly exposed and unauthorized tampering.



*We reserve the right to incorporate our latest design and material changes without notice or obligation.*

*Design features, materials of construction and dimensional data, as described in this manual, are provided for your information only.*

Rev. 1 – 11/2015