

## Cycle Lock CL Explosion decoupling ATEX

for usage in areas with explosion hazards

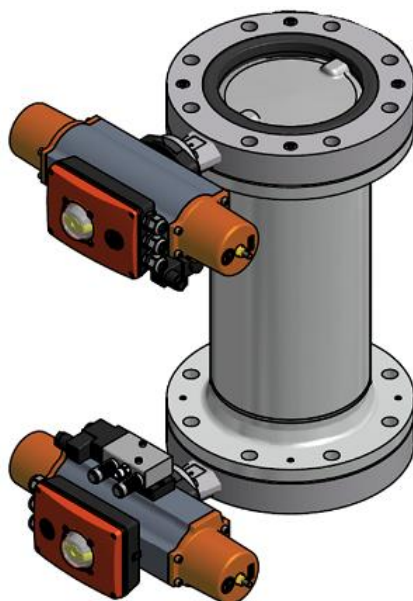

Example illustrations, all possible model variations are not displayed!

## Original - Assembly Manual with the operating instructions and technical annex

in accordance with EC Machinery Directive 2006/42/EC  
in accordance with EC Pressure Equipment 2014/68/EC  
in accordance with EC-ATEX Directive 2014/34/EC

*Language version English*

Revision: 17-09.2019



# Table of Contents

	Page
<b>A) GENERAL INFORMATION</b>	<b>6</b>
A01 MODEL EXAMINATION TESTED MODEL OVERVIEW (PROTECTION SYSTEM)	6
A02 DESIGN OF THE HAZARD SYMBOLS	7
A04 USED TERMS	9
A05 ABOUT THIS OPERATING MANUAL	10
A06 NOTE ON COPYRIGHT AND TRADEMARK	11
A07 WARRANTY AND LIABILITY	11
A08 LEGAL REGULATIONS	11
A09 NOTES FOR THE OPERATOR	11
A10 QUALIFIED STAFF	13
A11 TRAINING AND EDUCATION	15
A12 IDENTIFICATION OF THE CYCLE LOCK	15
<b>B) SAFETY NOTES</b>	<b>15</b>
B01 GENERAL SAFETY NOTES	16
B02 PROPER USAGE	17
B03 ORGANIZATIONAL MEASURES	20
B04 SAFETY NOTES FOR THE OPERATING STAFF	20
B05 SAFETY NOTES FOR OPERATING THE CYCLE LOCK	21
B06 SAFETY NOTES FOR MAINTENANCE AND UPKEEP	21
B07 SAFETY NOTES FOR WORKING ON THE PNEUMATIC SYSTEM	23
B08 SAFETY NOTES FOR WORKING ON THE ELECTRICAL SYSTEM	24
B09 SAFETY NOTES FOR HANDLING OPERATING SUPPLIES OR MEDIA	25
B10 SAFETY NOTE FOR DEALING WITH HOT SURFACES	26
B11 SAFETY NOTE FOR DEALING WITH COLD SURFACES	27
B12 SAFETY NOTES FOR USAGE IN AREAS WITH EXPLOSION HAZARDS	28
B13 SAFETY NOTES FOR ELECTRICAL INSTALLATION IN AREAS WITH EXPLOSION HAZARDS	31
B14 ATEX DIRECTIVE 2014/34/EC MANUFACTURER	32
B15 ATEX DIRECTIVE 1999/92/EC CYCLE LOCK OPERATOR	32
B16 RESIDUAL HAZARDS	33
B17 HAZARDS THROUGH PREDICTABLE MISUSE	34
<b>C) USAGE CONDITIONS</b>	<b>35</b>
C01 TEMPERATURES - ENVIRONMENT	35
C02 TEMPERATURES - MEDIA	35
C03 SURROUNDING CONDITIONS	35
C04 SETUP CONDITIONS	35
C05 OPERATING PRESSURE	35
D01 STORAGE	36
D02 PACKAGING	36
D03 GENERAL TRANSPORTATION	36
D04 TRANSPORTATION OF THE CYCLE LOCK WITH A FORK LIFT	37
D05 TRANSPORTATION OF THE CYCLE LOCK WITH A CRANE	37



D06	THE LIFTING GEAR HITTING THE CYCLE LOCK	38
<b>E)</b>	<b>ASSEMBLY MANUAL</b>	<b>39</b>
E01	ASSEMBLY OF THE CYCLE LOCK IN A TUBING SYSTEM	39
E02	ASSEMBLY OF THE CYCLE LOCK - STEPS DURING INSTALLATION	42
E03	ASSEMBLY OF THE CYCLE LOCK AS THE END FIXTURE OF A TUBING SYSTEM	43
E04	CONNECTION OF THE ELECTRICAL COMPONENTS	44
E05	ELECTRICAL CUSTOMER CONNECTION	46
E06	ELECTRICAL CUSTOMER CONNECTION - OFFSET CONTROL BOX	47
E07	CONTROLLING THE CYCLE LOCK	47
E08	CONNECTION OF THE PNEUMATIC COMPONENTS	49
E09	CONNECTION OF THE PNEUMATIC COMPONENTS - STEPS CONNECTION DRIVE	52
E10	DISASSEMBLY OF THE CYCLE LOCK	53
<b>F)</b>	<b>TEST RUN AFTER INSTALLATION</b>	<b>56</b>
F01	TEST RUN	56
F02	PRESSURE CHECK	58
<b>G)</b>	<b>PRODUCT DESCRIPTION</b>	<b>59</b>
G01	PROPER USAGE	59
G02	SCOPE OF DELIVERY	61
G03	DESCRIPTION OF THE COMPONENTS	62
G04	FUNCTIONAL PROCESS OF THE CYCLE LOCK	63
G05	FUNCTIONAL PROCESS OF THE LOCKING	65
G06	SOFTWARE TECHNICAL LOCKING	66
G07	SAFETY SETTING	66
<b>H)</b>	<b>OPERATION AND VISUALIZATION</b>	<b>67</b>
H01	GENERAL NOTE ON OPERATION	67
H02	OPERATING SETUP ON THE TOUCH PANEL	67
H03	MAIN SCREEN	68
H04	SET UP SCREEN	69
H05	MANUAL SCREEN	71
H06	PROCESS TIMES SCREEN	72
H07	CONTROL SCREEN (OTHER VALUE)	73
H08	OPERATOR SCREEN	74
H09	MAINTENANCE MANAGEMENT SCREEN	75
H10	CLOCK COUNTER SCREEN	76
<b>I)</b>	<b>PROGRAMMING SPS</b>	<b>77</b>
I01	PROGRAM ORGANIZATION	77
I02	SOFTWARE TECHNICAL LOCKING	78
I03	ACCESS PROTECTION	78
I04	SAFETY SETTING	78



I05	EXTERNAL CONTROL	78
<b>J)</b>	<b>SETTING AND ADJUSTING</b>	<b>79</b>
J01	GENERAL SETTINGS	79
<b>K)</b>	<b>MAINTENANCE AND UPKEEP</b>	<b>81</b>
K01	GENERAL MAINTENANCE AND UPKEEP	81
K02	MAINTENANCE INTERVALS	83
K03	CLEANING OF THE CYCLE LOCK BEFORE INSTALLATION	84
K04	GENERAL CLEANING OF THE CYCLE LOCK	84
K05	MAINTENANCE OF THE DRIVES	85
K06	MAINTENANCE OF THE FIXTURE	85
<b>L)</b>	<b>DISRUPTIONS, CAUSES AND REPAIR</b>	<b>86</b>
L01	GENERAL DISRUPTIONS	86
L02	ERROR DISPLAY SCREEN	87
L03	ERRORS – CAUSE – REPAIR	88
<b>M)</b>	<b>DISPOSAL</b>	<b>91</b>
M01	ENVIRONMENT PROTECTION	91
<b>N)</b>	<b>SPARE PARTS</b>	<b>92</b>
N01	GENERAL SPARE PARTS	92
N02	SPARE PARTS ORDER	92
<b>O)</b>	<b>TECHNICAL DATA</b>	<b>93</b>
<b>P)</b>	<b>INDEX</b>	<b>94</b>

Additional information and current addresses from our branches and trade partners can be found under:

[www.ebro-armaturen.com](http://www.ebro-armaturen.com)

EBRO ARMATUREN GmbH  
Karlstraße 8  
D-58135 Hagen  
☎ (02331) 904-0  
Fax (02331) 904-111





## A) General Information

### A01 Model examination tested model overview (protection system)

Model	Description
cycle lock CL Ex-Decoupling ATEX without PLC	Passive explosion technical decoupling equipment for use in areas with explosion hazards. The functions are controlled by the customer. With integrated safety function PL d according to DIN EN ISO 13849-1:2016-06
cycle lock CL Ex-Decoupling ATEX with PLC	Passive explosion technical decoupling equipment for use in areas with explosion hazards. The functions are controlled via a PLC installed in the control box. With integrated safety function PL d according to DIN EN ISO 13849-1:2016-06

#### Valves:

Valves are exclusively suitable for the application and type-tested in accordance with Directive 2014/34/EU in a flameproof and pressure-shock-proof design which have a device category according to Directive 2014/34/EU which is sufficient in accordance with the cycle sluice design.

#### Drives:

Model	Manufacturer	Design
EBX.1 – SYS	EBRO	Single working, safety setting CLOSED

## A02 Design of the hazard symbols

The hazard symbols can be found in the safety notes, which point out particular hazards for people or property. They are all designed in a uniform manner in this operating manual and must be observed.

---

			
General hazard	Electrical voltage	Hand injuries	Explosion

---

<b>Keyword</b>	<b>Meaning</b>
HAZARD	Points out a threatening hazard that will lead to severe injuries or death if the identified instruction is not followed completely.
WARNING	Points out possible hazardous situations that could lead to severe injuries or death if the identified instruction is not followed completely.
CAUTION	Indicates a possible hazardous situation or unsafe, hazardous procedures that could lead to injuries or property damage to the cycle locks or their surrounding area

---

### Structure of the safety notes

Keyword	Type and source of hazard
	Explanation
Hazard symbol	Measures to prevent the hazard

---

Follow the respectively named safety notes and behave with particular caution in these areas! Also share all safety notes with other users!  
 In addition to the notes in the operating manual, the generally valid safety and accident prevention guidelines must be considered!

### A03 Design of the note symbols



The note symbols are located where there are circumstances or activities, which help guarantee a safe, proper and efficient handling with the cycle lock. They are all designed in a uniform manner in this operating manual and must be observed.



Protective gloves

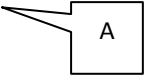

Eye protection

Symbol	Meaning
	This symbol points out that electrical components and cycle locks must be turned off and secured against being turned on again during all work, before maintenance and repairs.
	This symbol is located where there are circumstances or activities, which help guarantee a safe, proper and efficient handling with the cycle lock. All notes should be fulfilled in the interest of a proper usage of the cycle locks. Share all notes with other users as well!
•	Work and/or operating steps are marked with the bullet. The steps must be executed from top to bottom!
	Components and their installation spot within the cycle locks are identified with the square and round keys and a letter. Remember that the letters are assigned again for every chapter and always start with A.

Notes and symbols directly installed on the cycle locks, like warning signs, activation signs, rotating direction arrows, component identifications, etc. must be observed. The notes and symbols attached directly on the cycle locks may not be removed and must be kept in a completely legible condition!





#### **A04 Used terms**

cycle lock CL Ex-decoupling (CL - cycle lock) with functional safety for explosive areas.

For this incomplete machine for batching and dosing products, the term cycle lock, machine or system is used in the following text.

Product

For the products to be delivered, the term medium/media, product or basic material is used in the following text.

Operating personnel

For the operating personnel or the users of the cycle lock, the term operator is used in the following text.

This group of people is trained at the cycle lock and informed about the possible hazards.

### A05 About this operating manual

This operating manual is valid for the cycle lock in the safety version with functional safety to use in explosive areas. The cycle lock serves for delivering and, if applicable, dosing media from silos, containers, hoppers, etc.

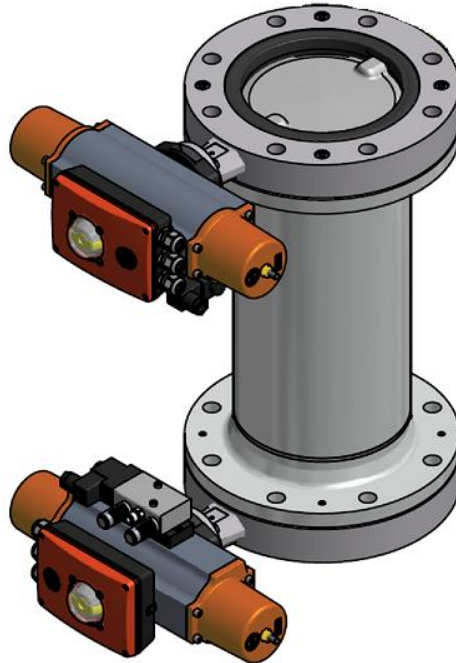

The cycle lock in the incomplete machine delivered by EBRO ARMATUREN was designed for the installation in a pipe system or for the attachment to a silo, container or similar system.

When operating the cycle lock, in addition to this operating manual, you must also observe the operating manuals from our suppliers.

This operating manual serves for safe work on and with the cycle lock and represents a significant help for the successful and safe operation of the cycle lock.

It contains important notes on how to operate the cycle lock in a safe, proper and efficient manner and to use the complete scope of functions of the cycle lock. Their observation helps to avoid hazards, lower repair costs and failure times and increase the reliability and lifespan of the cycle lock.

Furthermore, the operating manual should allow the users to execute any maintenance or repair work to the cycle lock independently for daily usage. It contains safety notes that must be observed.

All people who work on and with the cycle lock must have the operating manual accessible and observe the tasks and notes relevant for this.

The operating manual must always be complete and in a completely legible condition.

The EBRO ARMATUREN GmbH put together all specifications of this documentation with the greatest care. Nevertheless, EBRO ARMATUREN cannot rule out deviations and EBRO ARMATUREN reserves the right to technical changes to the cycle lock without prior notice. EBRO ARMATUREN does not take over any legal responsibility or liability for damages that may arise through this. EBRO ARMATUREN will include any necessary changes in the following requirements.



### **A06 Note on copyright and trademark**

Without special consent from the EBRO ARMATUREN GmbH, no part of this documentation may be reproduced or made accessible to third parties. It may only be made accessible to authorized people. This documentation, including all of its parts, has copyright protection. Reproductions, translations, microfilming and the saving and processing in electronic systems require the written consent from the EBRO ARMATUREN GmbH.

Violations can be penalized and may obligate to compensation.

All rights to exercise commercial protective rights are given to the EBRO ARMATUREN GmbH.

### **A07 Warranty and liability**

The warranty and liability are based on the contractually determined conditions. For warranty conditions, see sales and delivery conditions from the EBRO ARMATUREN GmbH.

Report any guarantee or warranty claims to the EBRO ARMATUREN GmbH immediately after a defect or error is determined. The guarantee or warranty expire in all cases in which no liability claims can be asserted.

In the event of software changes without the knowledge and authorization from the EBRO ARMATUREN GmbH, the liability and warranty claim expires.

Illustrates and drawings serve for general illustration and may deviate from the delivered cycle lock . The EBRO ARMATUREN GmbH does not take over any guarantee for damages that occur through improper usage, improper storage or improper transportation.

### **A08 Legal regulations**

The information, data and notes specified in the operating manual were up to date at the time of printing. No claims for already delivered cycle lock may be asserted from the specifications, figures and descriptions.

The company EBRO ARMATUREN GmbH does not take over any liability for damages and operating disruptions that arise through:

- the assembly.
- the incorrect operation and troubleshooting during operation.
- the repair (maintenance, care, commissioning)
- improper usage.
- independent changes to the cycle lock.
- improper work on and with the cycle lock.
- operating and adjustment errors.
- program errors to the control.
- non-observance of existing standards, directives and accident prevent guidelines.
- non-observance of operating manuals from the supplier.
- non-observance of this operating manual.

### **A09 Notes for the operator**

The operator is any natural or legal person who uses the cycle lock or uses the cycle lock on their behalf. The operator is the person responsible for safety.

The operator or their representative must make sure that:



- all relevant guidelines, notes and laws for accident prevention and operating safety are complied with;
- after construction and connection of the cycle lock, the complete cycle lock corresponds to the corresponding directives and the cycle lock conformity is established for the complex cycle lock.
- the required protective equipment and the EMERGENCY STOP equipment are installed and programmed in connection with the construction-side cycle lock.
- only qualified staff works on and with the cycle lock.
- the staff has the operating manual available during all corresponding work and follows it as well.
- unqualified staff do not work on and with the cycle lock.
- during installation or maintenance work for the cycle lock, the required accident prevention guidelines and safety guidelines are complied with.
- during installation or maintenance work for the cycle lock, the operating manuals and safety notes from the supplier are complied with.

The operating manual must be amended by the operator for operating instructions due to national accident prevent guidelines and environment protection guidelines, including the information about supervisory and reporting obligations for thee consideration of operational particularities, for example, in regards to work organization, work procedures and staff used.

In addition to the operating manual and the accident prevention regulations valid in the user country, as well as at the place of usage, the recognized technical rules or the state of technology must be observed for health and safety protection.



### A10 Qualified staff

Qualified staff includes people who can execute the required activities on the cycle lock due to their training, experience, education and knowledge. They possess knowledge about local standards, conditions, accident prevention guidelines and operating circumstances and have been authorized by the responsible individuals for the safety of the cycle lock, who also execute the respectively required work. They must be able to recognize and avoid possible hazards.

The staff who have learned and been trained at EBRO ARMATUREN GmbH may work with the cycle lock. Furthermore, they may also train other people in the usage and functions of the cycle lock. Otherwise special knowledge is required for certain tasks and activities. This may only be done by trained specialists.

Activities	Trained People	Trained People with technical education	Electr-specialists	Pneumatic specialists
Installation / setup		•	•	•
Commissioning		•	•	•
Operation	•			
Troubleshooting mechanical	•	•		
Troubleshooting electrical			•	
Troubleshooting pneumatic				•
Cleaning	•			
Maintenance		•	•	•
Work on the electrical system			•	
Work on the pneumatic system				•
Packaging and transportation	•			
Work on safety components or on the safety chain	Trained and educated staff from the company EBRO ARMATUREN GmbH			



The work and activities on the cycle lock in the "normal area" (green) may only be executed by qualified staff, please also observe the chapter *Qualified Staff*.

Work and activities in the "safety area" (yellow) may only be executed by employees from the EBRO ARMATUREN GmbH.

- The operating staff is obligated to examine the cycle lock and their functional groups at least once per shift for external damages and defects. Changes, including the operating behavior, that impair safety must be reported immediately and repaired by the EBRO ARMATUREN GmbH.

Within the protection equipment, no change to the connecting cables, clamp and plug connections and all other connections may be executed.

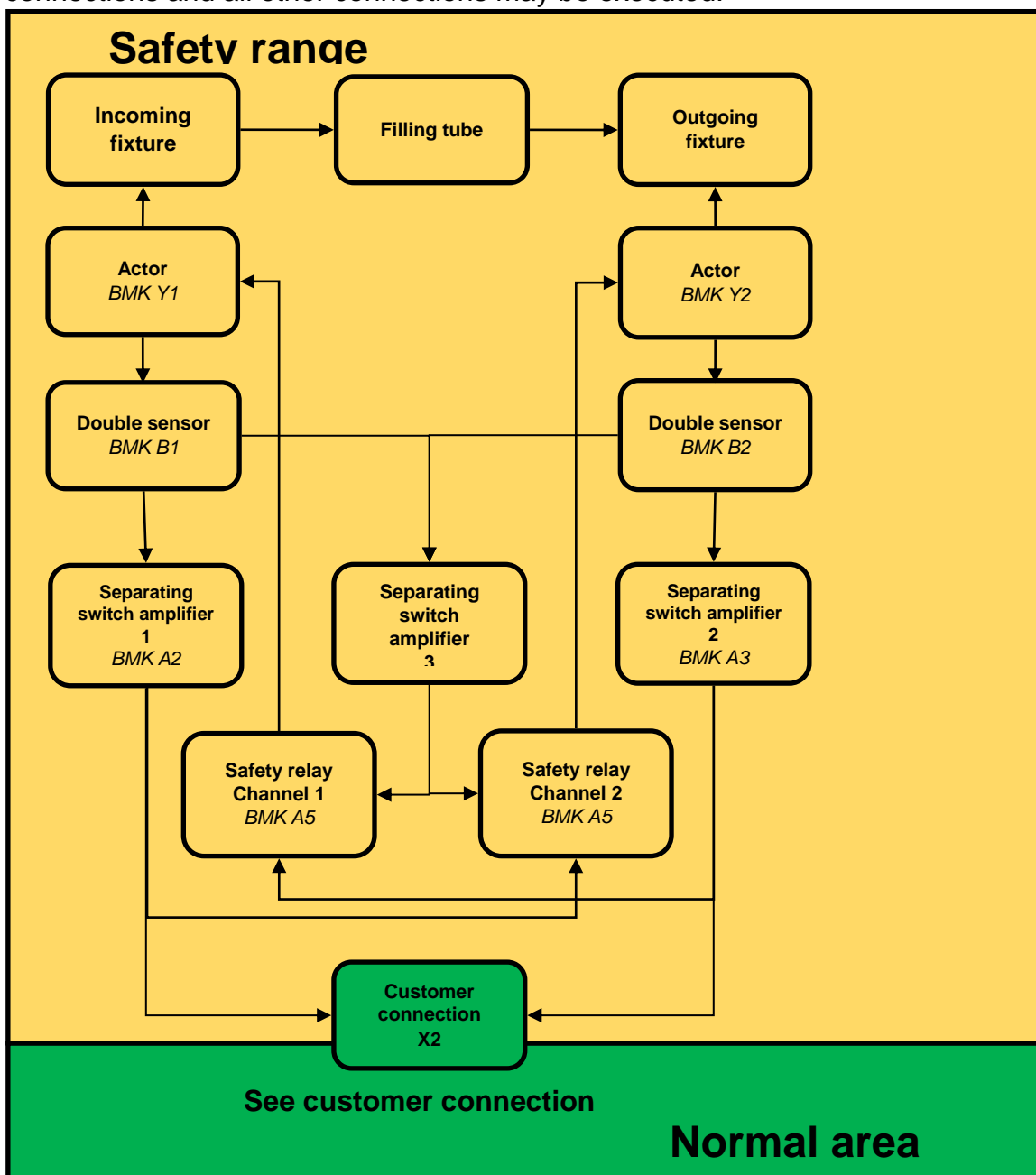

### A11 Training and education

As the operator, you are obligated to inform and instruct the operating and maintenance staff about the existing safety and accident prevention guidelines as well as about existing safety equipment on the cycle lock.

The different technical qualifications from the employees must be considered here.

The operating staff must have understood the instructions. Furthermore, it must be guaranteed that the training has been observed. This is the only way you can guarantee the safety and hazard conscious work from your staff. This should be examined regularly. As an operator, therefore, you should have the participation in the training or education confirmed in writing by every employee.

If there is still further need for educating the operating staff after handing over the cycle lock, please contact the EBRO ARMATUREN GmbH for the purpose of agreeing on the conditions.

### A12 Identification of the cycle lock

All standard individual components from the cycle lock are equipped corresponding with a label.

Each cycle lock bears the identification of the following data on the casing or sign:

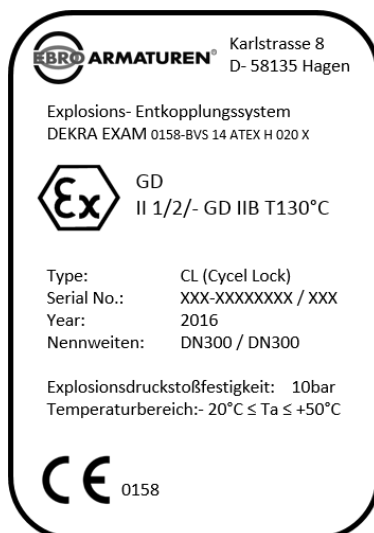

example for a protection system suitable for inside Zone 0/20 external Zone 1/21

with remote control unit (outside the Ex Zone)

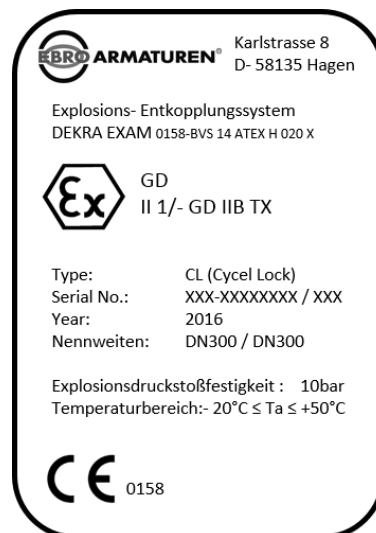

example for a protection system inside Zone 0/20 external no Ex- Area

The label should not be covered so that the installed cycle lock is always identifiable.

Identification of devices for operation in explosive areas according to the ATEX product directive 2014/34/EC

The ATEX directive 2014/34/EC requires:

"ex sign" ATEX logo

Device group

Category in accordance with definition in ATEX directive 2014/34/EC (1G, 2G, 3G, 1D, 2D, 3D)

Identification corresponding to the applied standards

CE sign (see also [CE-sign](#))

For products requiring production monitoring by a named site, the respective number of the named site must be specified with the CE sign. This applies to systems/devices with an EC type examination certificate.



## **B) Safety notes**

### ***B01 General safety notes***

This manual contains safety notes for predictable risks during construction, connection, operation and disassembly of the cycle lock.

The operator is responsible for completing these notes for others, specifically locally or through the process related risks.

For questions and problems, please contact the company EBRO ARMATUREN GmbH.

At the time of delivery, the cycle lock corresponds to the state of technology and is basically seen as safe for operation.

There are hazards coming from the cycle lock for people, the cycle lock itself and other objects belonging to the operator if:

- unqualified and untrained staff works on and with the cycle lock.
- the cycle lock is used improperly and inappropriately.
- the cycle lock is improperly set, maintained, repaired, programmed or connected.

The cycle lock must be set and equipped so that in the event of proper setting, equipping and usage, it fulfills its functions in problem-free operation and does not represent any hazard for people. Through suitable measures, make sure that no property damage is caused if the cycle lock fails. Operate the cycle lock only in a proper state. Additions, changes or restructuring to the cycle lock are forbidden. They require agreement with the EBRO ARMATUREN GmbH.





## B02 Proper usage

This EBRO cycle lock of the CL model, which is installed

- a) as a complete functional unit read to be installed in a total system
  - underneath a storage container (for example, a silo),
  - above the system section "further processing or disposal" with flanges,
- b) should normally receive dust-shaped/grainy solids from the silo up top into the system below and be moved in sequence according to the guidelines from the user through gravity or pneumatic transportation.
- c) It consists of the components:
  - Distance tube with flanges to accept the "sequence volume".  
This pipe can optionally be equipped with a level sensor, which sends an electrical signal depending on the filling in the distance pipe.
  - Depending on the block fixture, attached on the top and bottom of the distance pipe:  
Normally, this is a block flap in the short construction length with flange eyelets in the casing with an elastomer sleeve for seal-proof closing.
  - Each of the two block flaps is equipped with a pneumatic moving drive - normally with the spring package for the "fail safe setting "CLOSED".  
The drives must be connected to the user-side "compressed air" supply network.
  - Each of these drives is activated through an included accessory unit "magnet valve"/setting detector.
  - A "control" component is also delivered, through which the two magnet valves open and close the two block flaps "in sequence",
  - and through which the signals of the two aforementioned position detectors guarantee that the two block flaps are in an alternate "sequence".



- d) This functional unit
- normally fulfill the requirements from the EC Pressure Device Directive (DGRL) 2014/68/EC;
  - if it is delivered as a complete functional unit, it is an "incomplete machine" in terms of the EC Machine Directive (MRL) 2006/42/EC.  
Only after it has been installed with the two flange ends between the upper silo and lower (pipe) system and screwed in tight, it is completely closed and therefore a "complete machine" in terms of this MRL.
  - The cycle lock can be delivered for media with pressure of up to 10 bar and temperatures up to 160°C - the manufacturer Ebro ARMATUREN and the user/orderer determine which active substances are used for all components depending on this.
  - The user must guarantee that the active substances used for the parts of the cycle lock coming into contact with the media are suitable for fluids.
  - The cycle lock can - *but only on special customer request* - fulfill the requirements of the directive 2014/34/EC as a **"device" in terms of the ATEX** and is optionally equipped in all mechanical and electrical components in a special design so that it is  
→ **ex-safe for environment zones**  
and does not represent a potential ignition hazard for the following class division according to ATEX directive 1999/92/EC: Zone 1 or 21 or 2 or 22.

The maximum surface temperature of the interlock is determined, among other things, by the installed attachments, which have a maximum surface temperature of 130°C or (temperature class T4). If, in addition, a media temperature  $T_F$  of more than 130°C is to be taken into account, the safety parameters of the explosive substances which may occur in the installation area must have a sufficient safety distance to the maximum media temperature. According to this, the following boundary conditions must be observed.

Dust must have the following safety-related characteristics:

Ignition temperature  $\geq 195^\circ\text{C}$  and  $\geq 3/2 \cdot T_F$  determined according to DIN EN 50281-2-1  
Melt temperature  $\geq 205^\circ\text{C}$  and  $\geq T_F + 75\text{ K}$  determined according to DIN EN 50281-2-1

Gases or vapours must have the following safety characteristics:

Ignition temperature  $> 135^\circ\text{C}$  and  $\geq 1.25 \cdot T_F$  determined according to DIN EN 14522  
Explosion group IIA or IIB determined according to DIN EN 60079-20-1



- Another option is that all internal parts of the cycle lock can be equipped so that they do not possess a potential ignition hazard for zone inside in the tube system 0 or 20 or 1 or 21 or 2 or 22. Since the temperature of the cycle lock inside is determined by the medium temperature  $T_F$ , the following boundary conditions must be observed:

Dust must have the following safety-related characteristics:

Ignition temperature  $3/2 \cdot T_F$  determined according to DIN EN 50281-2-1

Melt temperature  $T_F + 75 \text{ K}$  determined according to DIN EN 50281-2-1

Gases or vapours must have the following safety characteristics:

Ignition temperature  $1.25 \cdot T_F$  determined according to DIN EN 14522

Explosion group IIA or IIB determined according to DIN EN 60079-20-1

- Independent of this, the cycle lock - but only on special customer request - may be delivered for all of the zones mentioned above in the inner tube system with specially set-up control - **as a "protection system"** in terms of ATEX.

In this special design, the cycle lock is capable of restricting a beginning dust explosion - either above in the silo or below in the tube system - so that this explosion cannot continue in the upper or lower part of the tube system.

For this purpose it must be ensured that an explosion pressure of 1 bar, 3 bar, 6 bar or 10 bar (see information on explosion pressure shock resistance on the type plate) is not exceeded by explosion processes from upstream and/or downstream system components, depending on the pressure shock resistance of the interlock. The cycle locks are flameproof against explosions of combustible gases whose explosion behaviour does not exceed that of propane gas explosions, as well as dust of dust explosion classes St 1 and St 2.

*Please also note the supplementary information for proper use in chapter "G01 Proper usage".*



### **B03 Organizational measures**

The cycle lock was constructed and built according to the state of technology and the recognized safety-technical rules. In order to avoid hazards for the users and impairments to the cycle lock and other objects, the following organizational measures must be complied with:

- Observation of the proper usage of the cycle lock.
- Operation of the cycle lock in a technically proper state.
- Usage of adequately qualified staff.
- Compliance with the maintenance interval.
- Observation and compliance with the hazard signs and signs by the cycle lock.
- Observation of this operating manual and the operating manuals from the suppliers of the purchased components.

The operating manual must always be stored on the cycle lock within reach. The staff assigned with activities on the cycle lock must read the operating manual, in particular the safety notes chapter, before beginning the work. This applies in particular for staff that is only occasionally active at the cycle lock. Spare parts must correspond to the technical requirements while operating the cycle lock. This is guaranteed with original spare parts from EBRO ARMATUREN GmbH.

The area surrounding the cycle lock must be kept in a clean and proper state. Contaminations and impairment of the cycle lock functions as well as restrictions in the user's freedom of motion may lead to disruptions and accidents.

The cycle lock may only be operated by staff with the corresponding qualifications.

The operating staff is obligated to examine the cycle lock and their functional groups at least once per shift for external damages and defects. Changes, including the operating behavior, that impair safety must be reported immediately and repaired.

### **B04 Safety notes for the operating staff**

The cycle lock may only be used in a technically proper state as well as properly, safety and hazard conscious under observation of this operating manual! All disruptions and in particular those that can impair safety must be repaired immediately!

Any person who is assigned with the setup, operation, commissioning or maintenance of the cycle lock must have read and understood this operating manual before beginning their work - in particular the *Safety* chapter. This applies in particular for staff who is only occasionally used at the cycle lock.

No liability will be taken over for any damages and accidents that occur through the non-compliance of the operating manual.

The standard accident prevention guidelines as well as the other generally recognized safety and work health rules must be complied with.

The responsibilities for the different activities within the scope of the operation, maintenance and repairing of the cycle lock must be clearly set and complied with. Only then can incorrect actions - in particular in hazardous situations - be avoided.

The operator must obligate the operating and maintenance staff to wear personal protection equipment. This includes in particular safety shoes, safety gloves, protective goggles, protective clothing, ear protection and tight work clothing.

Do not wear long open hair, loose clothing or jewelry! There is the risk of injury by getting stuck on, suck into or moved by mobile parts!

If there are safety relevant changes to the operating behavior or disruptions to the cycle lock, it must be stopped immediately and the process must be reported to the responsible person!



First aid equipment like bandage sets, eye flushing bottles, fire extinguishers, etc must be stored within reach!

Work on the cycle lock may only be done by reliable, qualified personnel. The legally permissible minimum age must be observed!

Only trained or educated staff may be used!

Staff that must be trained, taught, instructed or are currently in an apprenticeship may only work with the cycle lock under the constant supervision of an experienced, qualified person!

### ***B05 Safety notes for operating the cycle lock***

For all work that affects the operation, equipping or adjusting of the cycle lock and its safety equipment, the inspection, maintenance and commissioning, the switch on and off processes must be observed in accordance with this operating manual and the notes for maintenance!

The cycle lock may only be operated in a complete and operable state.

The cycle lock is suitable for operation in areas with explosive hazards!

Before beginning work, the staff must be familiar with the work environment around the cycle lock.

Before turning on the cycle lock, it must be guaranteed that nobody is within the hazard area and can be put in danger by starting the cycle lock!

The cycle lock must be examined for externally recognizable damage at least once a shift. Changes (including those to the operating behavior) must be reported immediately to the responsible technician or works manager

If there are functional disruptions to the cycle lock, stop these immediately and secure. Have disruptions repaired immediately by trained technicians.

### ***B06 Safety notes for maintenance and upkeep***

Banking off (for example, gate valves) of upstream and, if applicable, downstream areas before the disassembly of the cycle lock so that no product can slide down during unattended work or escape from the downstream areas.

The operating staff must be informed about the execution of special and maintenance work before it is executed. A supervisor must be named.

The periods for recurring inspections, maintenance or upkeep required or specified in the operating manual must be complied with.

For the execution of maintenance and upkeep measures, factory equipment appropriate for the work is required.

Additionally illuminate maintenance and upkeep areas, if required, with manual or standing lamps.

The upkeep area, if required, must be blocked off generously!

The cycle lock must be completely turned off for maintenance, repair and upkeep work and secured against unexpectedly being turned on again.

In order to avoid electric shocks, do not open any electrical components, casings and covers.

Do not touch damaged, torn parts, in particular those with voltage.

Regularly examine and, if applicable, replace seals from electrical casings.

Cleaning of the cycle lock environment so that no explosive atmosphere can be created during the maintenance and upkeep.

Always re-tighten any screws that have become loose during maintenance and upkeep work! All screws must be tightened with a torque wrench and the corresponding tightening torque.

If the disassembly of the safety equipment is required during maintenance or upkeep, the assembly and examination of the safety equipment must be carried out immediately after completion of the maintenance and repair work!

Individual parts and larger components must be carefully mounted to lifting equipment when replacing and secured so that the hazard arising from them is kept to a minimum. Only use suitable and technically proper lifting equipment and load handling equipment with adequate carrying capacity!



Do not stand or work under lifted loads.

Only assign experienced people with the lifting of loads and instructing of crane operators! The instructor must be in the operator's field of vision or be in contact with them!

In the event of assembly work over a height of 1.60 m, designated or miscellaneous safety climbing aids and platforms must be used! Do not use cycle lock parts and tubing systems as climbing aids!

For standing places or for work at heights higher than 1.0 m, corresponding fall-safety mechanisms must be provided! All handles, steps, railings, pedestals, platforms, ladders must be free of dirt!

The cycle lock, and here in particular the connections and screws, must be freed of all dirt and residues, like oil, operating materials or cleaning agents, at the beginning of the maintenance, upkeep and care.

Do not use any aggressive or solvent-containing cleaning agents. Use fiber-free cleaning cloths.

Only use mild cleaning agents on a water basis. Observe the specifications from the manufacturer. Do not use any organic solvents, because this results in a fire and explosion hazard!

Before cleaning with water, vapor steam (high pressure cleaner) or other cleaning agents, cover or tape up all openings from the cycle lock in which no water, steam or cleaning agent should enter due to safety and functional reasons. Electrical components, control units, switch boxes and clamp casings are particularly in danger. After cleaning, completely remove the covers or tapes.

Make sure the operating and auxiliary materials are disposed of in a safe and environment-friendly manner!

**B07 Safety notes for working on the pneumatic system**

The pressures required for the cycle lock may lead to injuries.

For repair work done to the compressed air parts, pressure lines to be opened must be made free of pressure before work is started.

The lines to be connected must be clearly and permanently marked, because hazards may arise from mix ups.

Operate the cycle lock only in a secure and functional state. The cycle lock may only be operated without recognizable external damage.

---

**HAZARD****Hazard through uncontrolled starting pneumatic components.**

Severe injuries with incorrectly connected pneumatic components or for pneumatic components that start without being controlled.

The pneumatic components may only be connected by a specialist.

All components and connections must be examined before turning on the pneumatic system.

---



**B08 Safety notes for working on the electrical system**

The operating voltage required for the system may have fatal consequences if one of the parts under voltage is touched. If there is a short circuit, the hazard of sparks forming and fire exist.  
 The connection of the system must be adequately dimensioned in order to prevent overload. In the event of disruptions to the electrical energy supply, turn off the cycle lock immediately.  
 Active parts of the electrical cycle lock under voltage may not be worked on.  
 Before beginning work with parts of the cycle lock that are supplied with electrical energy, turn off the cycle lock on the main switch and secure the cycle lock against being turned on unexpectedly. Otherwise a hazard through electrical voltage exists!  
 Only use original fuses with the prescribed current strength.  
 The electrical cycle lock must be in a secure state and maintained in this state. The electrical cycle lock must be examined regularly. Defective and loose connections, etc must be reported and repaired immediately.  
 The switch cabinet and all clamp and connection boxes must be closed at all times. Only authorized staff is permitted to access the electrical cycle lock for inspection and maintenance.  
 The active parts of the electrical cycle lock must be protected against direct contact corresponding to their voltage, frequency, usage type and operating location through insulation, location, arrangement or installed equipment.  
 The electrical cycle lock must be protected against indirect contact corresponding to its voltage, frequency, usage type and operating location so that in the event of an error in the electric cycle lock, protection against hazardous contact voltage is also provided.

**HAZARD**

**Risk of death through electrical voltage.**



Severe injuries or death through electric shock.

The connecting of the cycle lock may only be executed by an electrician.

Establish a freedom of voltage and secure the cycle lock against being turned on again.

An electrostatic charge may be created through friction from the media and through the high pressures. This charge may influence and disturb the operation of the cycle lock. That is why there must be sufficient grounding of the cycle lock.

**WARNING**

**Disruptions to operation through electrostatic charge.**



Disruptions or damage to components.

The connecting of the cycle lock may only be executed by an electrician.

The cycle lock must be grounded.



**B09 Safety notes for handling operating supplies or media**

When handling raw substances, solvents, oils, greases, media and other chemical substances, the applicable guidelines and safety specifications from the manufacturer of these substances in regards to storage, handling, usage and disposal must be observed and complied with!

When working with certain operating and hazardous substances, protective equipment made of suitable material must be worn (protective goggles, rubber gloves, rubber boots, protective clothing)! Pay attention to the specifications in the safety specifications for the operating or hazardous substance. The safety specifications will be provided to you by the respective manufacturer of the substance.

In the event of eye or skin contact, the affected spot must be immediately cleaned with a lot of water. Suitable facilities (eye flushing bottle, sink, shower) must be available near the workplace!

**CAUTION Hazard through operating or hazardous substances or through media.**



Severe injuries or damage to the cycle lock.

The safety specifications from the operating and hazardous substances must be present and observed.

Use the personal protection equipment required in the safety specifications when handling the respective hazardous substance.

**NOTE**

Use personal protection equipment.

When handling hazardous substance, the personal protection equipment specified in the safety specifications must be used.

Use the personal protection equipment.





### **B10 Safety note for dealing with hot surfaces**

During running operation of the cycle lock, very high temperatures may be found at certain spots in the area of certain components. Through radiation heat, it may be that not just the actual component, but rather also the components of the cycle lock or other components nearby may be very hot. This may cause a burning hazard by coming into contact with hot surfaces or by coming into contact with hot components!

Thus, make sure that adequate contact protection exists between people and hot surfaces and that no fire loads or flammable substances or materials are located near the hot surfaces.

Personal protection equipment (PPE), tight clothing and work safety boots must be used. When handling hot components or hot surfaces, heat resistant gloves should be worn.

Only operate the cycle lock when it is guaranteed that the rising, heated air can be securely and permanently guided out. Make sure that enough fresh air is added!

---

#### **HAZARD**

Hazard through hot surfaces.



Severe injuries or burns when coming into contact with hot surfaces in the area of the components and drives.

Before beginning work, you must allow the components with hot surfaces to cool down.

---

#### **NOTE**

Wear heat resistance gloves.



For components with hot surfaces, the operator must provide the employees with heat resistant protective gloves.

Use the personal protection equipment in the form of protective gloves.



## **B11 Safety note for dealing with cold surfaces**

During running operation of the cycle lock, very cold temperatures may be found at certain spots in the area of certain components. Through cold heat, it may be that not just the actual component, but rather also the components of the cycle lock or other components nearby may be very cold.

This may cause a cold burning hazard by coming into contact with very cold surfaces or by coming into contact with cold components!

Make sure that adequate contact protection exists between people and cold surfaces.

Personal protection equipment (PPE), tight clothing and work safety boots must be used. When handling cold components or cold surfaces, cold resistant gloves should be worn.

---

### **HAZARD**

#### **Hazard through cold surfaces.**



Severe injuries or cold burns when coming into contact with cold surfaces in the area of the components and drives.

Before beginning the work, you must heat up the components with cold surfaces in a natural manner.

When turning on the cycle lock, in particular it must be made sure that contact protection is installed on the cold components.

---

### **NOTE**

Wear cold resistant protective gloves.



For components with cold or cryogenic surfaces, the operator must provide the employees with cold resistant protective gloves.

Use the personal protection equipment in the form of protective gloves.

---

## **B12 Safety notes for usage in areas with explosion hazards**

The safety notes listed here for using the cycle lock in explosive areas must be considered by the operator. If these notes are not complied with, this may result in a hazard through fire or explosion. The observation in particular of the safety notes for explosive areas, but also all other safety notes, is required for the operator.

The company EBRO ARMATUREN GmbH delivers a cycle lock where all of the used components, materials and control components (electrically and pneumatically) correspond with the requirements of the listed directives.

For the cycle lock, the same safety guidelines apply as for the tubing system in which it is installed. The operator of the cycle lock is responsible for installing, connecting and using the cycle lock within the scope of the specifications in this operating manual.

This responsibility is not by the manufacturer of the cycle lock.

The media that flows through the cycle lock, which may have a high temperature, may not lead to an increase in the surface temperature of the cycle lock. The maximum permissible surface temperature may not be exceeded.

Any layers of dust on the components from the cycle lock may decrease the heat exchange of the cycle lock with the surrounding air. This may lead to a heat backup. In order to avoid impermissible temperature increase above the maximum surface temperature, deposits or layers of dust must be removed if present.

---

### **HAZARD**



**Life hazard through increased surface temperature in the explosive area.**

Severe injuries or death through explosion or fire.

When operating the cycle lock, it must be made sure that the media or dust deposits do not lead to an increase in the surface temperature. Observe the technical data for this.

Remove dust deposits from the cycle lock!

---

The compressed air required for the pneumatic mobile drives must be extracted and provided outside of the ex-area from the surrounding air. Here it must be made sure that the fed compressed air does not contain any components or particles that may contribute to an explosion hazard. Furthermore, it must be guaranteed that an impermissible heating up of the fed compressed air cannot lead to an increase in temperature that would be above the maximum permissible surface temperature.

---

### **HAZARD**



**Deathly hazard through components or high temperatures from the compressed air in the explosive area.**

Severe injuries or death through explosion or fire.

When operating the cycle lock, it must be made sure that the compressed air does not represent an explosion hazard, whether it is through components or high temperatures in the compressed air.

---

The switches from the cycle lock may not be so high that an impermissible temperature increase is caused that is above the maximum permissible surface temperature. That is why all mobile components have a relative speed of  $< 1 \text{ m}\cdot\text{s}^{-1}$ . Through this, the formation of ignitable striking and friction sparks, as



well as the ignition of media being heated up from surfaces by the switches from the cycle lock are not to be expected.

The maximum permissible dust layers may not exceed a thickness of 5mm.

During the assembly of the cycle lock in a tubing system, it must be guaranteed that the cycle lock and the tubing system are grounded so that there will not be an electrostatic charge that may lead to an explosion hazard.

The maintenance and assembly work may only be executed outside of the observed hazard areas of the explosion zone. This prevents an unintentional discharge in connection with a hazardous atmosphere.

With the delivered cycle lock, all components are connected with each other.

The cycle lock and the connected tubing system must be grounded.

The operator must therefore guarantee that the cycle lock and the tubing system are grounded through a secure grounder with a fixed grounding point. This applies in particular if insulating seals and screws made of non-conductive material are used.

The derivation resistance must be  $< 10^6 \Omega$ .

In order to avoid an ignitable discharge on the non-conductive paint coating, the layer thickness of the paint is  $\leq 0.2$  mm and therefore does not represent a hazard in connection with static charge. This applies only for the special case that the gases and vapors from explosion group II C are being used. If the previously mentioned relevant substances are present, the layer thickness through a further paint coating may not exceed the permissible layer thickness of 0.2 mm. If gases and vapors from group II A and II B exist, the total layer thickness may not be  $>$  than 2 mm.

Particularly when the connected tubing runs on empty, this may result in a hazardous, explosive atmosphere. Through the flow, electrostatic charges are created inside the tubing. The surface resistance of the tube helps to determine the amount of the charge. For this reason, only tubes made of conductive or deriving materials may be used. This applies specifically to plastic tubes and for tubes that are covered with plastic.

The operator must guarantee that the cycle lock is connected through an electrostatic conductive tubing connection or through a separate grounding point.

**HAZARD**



**Life hazard through non-existent grounding in the explosive area.**

Severe injuries or death through explosion or fire.

During the assembly and operation of the cycle lock, it must be made sure that the cycle lock with all of its components and tubing system is grounded.

**Ground cycle lock and tubing system through a secure grounding with a fixed grounding point!**



Through the switch process of the fixture and the solids in the moving medium, electrostatic charges may be created on a plastic coated panel.

In order to prevent propagating brush discharge, no coatings are used that have a disruptive voltage >4kV. All components or parts being used that have contact with the fed medium are selected from conductive or dissipative materials.

An electrostatic charging of existing plastic hoses cannot be ruled out through the friction of condensation on the inner walls of the hose, in connection with the flowing compressed air. These charges may lead to a hard, if there is accidental discharge, which is why they must be avoided. The operator must guarantee that the maintenance unit is always observed and the water collected here is emptied in regular intervals. Solid parts that are located within the compressed air and move along the inner wall of the hose may also lead to electrostatic charges.

The operator must make sure that a fine filter is installed at suitable spots. A suitable spot for the fine filter would be at a place before the compressed air passes the plastic hose.

The cycle lock operator is responsible for observing the local laws, orders and directives from the occupation safety association in regards to avoiding ignition hazards due to electrostatic charges in regards to the grounding, securing of conductive resistances, charging people, dissipative shoes, floors, clothing, gloves, protective helmets, etc. In the event of non-compliance, contact from the cycle lock in connection with an explosive atmosphere may represent an explosion hazard.

---

**HAZARD**

**Life hazard through the non-compliance with the guidelines in the explosive area.**

Severe injuries or death through explosion or fire.

During the assembly and operation of the cycle lock, it must be made sure that the applicable guidelines, directives, etc. are complied with and observed so that sources of ignition are not created due to electrostatic charges!

Observe the guidelines and directives on the operator side!

---



**B13 Safety notes for electrical installation in areas with explosion hazards**

The requirements from DIN EN 60079-14 must be observed.

During the construction and operation of the explosion protected controls and connection of the cycle lock, applicable national orders and regulations must be observed.

Work on electrical cycle lock and operating materials under voltage is forbidden in explosive areas.

This does not include work on the secure power circuits. In special cases, work on non-secure power circuits may be executed, whereby it must be guaranteed that no explosive atmosphere is present during this work.

The freedom of voltage can only be examined with explosion protection permitted measuring devices.

Grounding may only be executed if there is no explosion hazard at the grounding site.

Otherwise the safety notes for electrical work must be observed.

**HAZARD Risk of death through electrical voltage.**



Severe injuries or death through electric shock.

The connecting of the cycle lock may only be executed by an electrician.

Establish a freedom of voltage and secure the cycle lock against being turned on again.

**WARNING Disruptions to operation through electrostatic charge.**



Disruptions or damage to components.

The connecting of the cycle lock may only be executed by an electrician.

The cycle lock must be grounded.

**HAZARD**



**Life hazard through non-existent grounding in the explosive area.**

Severe injuries or death through explosion or fire.

During the assembly and operation of the cycle lock, it must be made sure that the cycle lock with all of its components and tubing system is grounded.

Ground cycle lock and tubing system through a secure grounding with a fixed grounding point!



### **B14 ATEX directive 2014/34/EC manufacturer**

The property requirements for equipment and operating equipment where there may be an ignition hazard were standardized throughout Europe. The requirements are listed in the product directive 2014/34/EC (also marked as ATEX 100a or ATEX 95). The directive describes the requirements for the "basic health and safety requirements as well as conformity evaluation procedures for electrical and non-electrical devices and systems that may be used in explosive hazard areas.

For the cycle lock from EBRO ARMATUREN, the conformity evaluation procedure of the EC model inspection was successfully applied in accordance with attachment III to the directive 2014/34/EC and completed with the obtainment of the EC model permit.

Furthermore, before delivery of the cycle lock, the production monitoring is guaranteed in accordance with 2014/34/EC by

- attachment IV (quality assurance) or
- attachment V (inspection of products by a named site)

The cycle lock system is identified in accordance with 2014/34/EC and contains a conformity declaration by the manufacturer, which is given to the operator together with the technical documentation.

### **B15 ATEX Directive 1999/92/EC cycle lock operator**

The ATEX operating directive 1999/92/EC (also named ATEX 118a or ATEX 137) describes the requirements for the operation of cycle lock in explosive areas. In the ATEX directive 1999/92/EC, the risk analysis (possible sources of ignition), the zone classification, the creation of explosion protection documents and responsible people for the cycle lock are described.

In a second step, a person knowledgeable in regards to explosion protection must check if the requirements from the explosion protection concept have been implemented and if the electrical and non-electrical devices are suitable for the respectively determined zone.

These tasks are all on the operator side of the cycle lock.

The operator is also responsible for the correct evaluation and classification of the explosion zones in their facilities. Furthermore, they must select the permitted electrical and non-electrical devices and systems according to their zone classification.

Corresponding to the determined explosion hazard zone in which a device should be used, the device category is determined.

---

#### **HAZARD**



**Life hazard through the non-compliance with the guidelines in the explosive area.**

Severe injuries or death through explosion or fire.

During the assembly and operation of the cycle lock, it must be made sure that the applicable guidelines, directives, etc. are complied with and observed so that sources of ignition are not created due to electrostatic charges!

Observe the guidelines and directives on the operator side!

---



## **B16 Residual hazards**

The hazards that come from the cycle lock occur during work within the actual limits of the cycle lock if you have to operate the cycle lock for work, for example, during:

- maintenance.
- equipping.
- troubleshooting and repairing.

Make sure to be accompanied by another person for maintenance, equipping or repair work where the cycle lock has to be operated so that they can turn off the complete cycle lock in the event of an emergency.

Work with extreme caution and attention.

Even when all safety guidelines are followed, there remains a residual risk when operating the cycle lock. Anybody who works on and with the cycle lock must know these residual risks and follow the instructions that prevent these residual risks from leading to accidents or damages.

---

### **HAZARD**

#### **Hazard through missing protection equipment.**



Severe injuries through moving components.

If protection equipment must be disassembled or shut down for adjustment and equipping work, all work must be executed in a well thought-out and conscious manner!

Any routine in the operating procedure must be avoided!

---

Furthermore, residual hazards may exist in regards to the explosion hazard if the local guidelines and rules are not applied. Here in particular the operator of the cycle lock is responsible, because they bear the responsibility for the zone classification, selection of the device category and normally the assembly as well.

---

### **HAZARD**



#### **Life hazard through the non-compliance with the guidelines in the explosive area.**

Severe injuries or death through explosion or fire.

During the assembly and operation of the cycle lock, it must be made sure that the applicable guidelines, directives, etc. are complied with and observed so that sources of ignition are not created due to electrostatic charges!

Observe the guidelines and directives on the operator side!

---

### **B17 Hazards through predictable misuse**

It is the responsibility of the operator to guarantee the proper usage of the cycle lock and to protect it from predictable misuse and must also consider the entire cycle lock in the safety evaluation.

- The settings and positions of the initiators and their activation elements may not be changed.
- The magnetic valves may not be disassembled and the pneumatic drives supplied directly with pneumatic energy.
- Within the protection equipment, no change to the connecting cables, clamp and plug connections and all other connections may be executed.

**HAZARD**

**Hazard through bypassing protection equipment.**



Severe injuries or death through explosion or fire.

When operating the cycle lock, it must be made sure that the protection equipment is fully functional and is not improperly operated through desired or undesired manipulation.

- Within the protection equipment, no change to the connecting cables, clamp and plug connections and all other connections may be executed.
- The disconnecting of contact and plug connections under voltage is prohibited.
- The cycle lock may not be separated from the grounding system.

**HAZARD**

**Life hazard through the non-compliance with the guidelines in the explosive area.**



Severe injuries or death through explosion or fire.

During the assembly and operation of the cycle lock, it must be made sure that the applicable guidelines, directives, etc. are complied with and observed so that sources of ignition are not created due to electrostatic charges!

Observe the guidelines and directives on the operator side!



## **C) Usage conditions**

### **C01 Temperatures - environment**

Environment temperature Usage area:

- Flaps with direct attachments
  - 0°C to + 50°C
  - 10°C to + 50°C
  - 20°C to + 50°C
- Reduced electrical unit 0°C to 50°C

A proper functionality of the cycle lock is guaranteed in this temperature range. For temperatures above and below the named temperatures, the functionality can no longer be guaranteed.

### **C02 Temperatures - Media**

The permissible media temperature range depends on the type of valve used and the intermediate pipe section. The minimum permissible media temperature is identical to the minimum permissible ambient temperature indicated on the rating plate of the cycle lock. The maximum permissible media temperature can be found on the nameplate of the installed valves. Depending on the design of the installed valves, maximum media temperatures of 70°C, 120°C or 160°C are permissible. In this temperature range for the media a faultless function within the cycle lock is guaranteed. At temperatures of the media outside the temperature range, the mode of operation can no longer be guaranteed, especially with regard to explosion pressure shock resistance and ignition breakdown protection.

### **C03 Surrounding conditions**

With the correct composition of the individual components, the cycle lock fulfills a degree of protection according to DIN of IP 67.

Surrounding media, in particular chemically aggressive media, may attack seals, hoses, cables and plastics.

The cycle lock can be installed permanently in explosion hazard areas form zone 1, zone 21, zone 2 and zone 22.

The zone in the tubing, different from the surrounding environment, may be a maximum of zone 0 or zone 20.

### **C04 Setup conditions**

The cycle lock should only be installed in an area that fulfills the requirements for the temperatures and surrounding conditions. The general directives for workplaces must be complied with as well.

Furthermore, the two fixtures must be screwed into the correct position and tightly with the tubing system.

The entire cycle lock may also be set up and operated in an explosion hazard environment.

The zone classification and device category must be paid attention to here.

### **C05 Operating pressure**

The maximum operating pressure in the tubing may not exceed the nominal pressure.

The explosion pressure shock resistance is indicated on the type plate of the cycle lock and must not be exceeded by the maximum operating pressure including explosion pressure. The explosion pressure shock resistance and ignition breakdown resistance of the interlock depend on the design of the installed fittings and the intermediate pipe section. A distinction is made between explosion pressure shock resistance of 1 bar, 3 bar, 6 bar and 10 bar.

## D) Storage, packaging and transport

### D01 **Storage**

If the cycle lock should not be installed immediately, make sure of suitable storage conditions in a dry, dust-free, frost-free area protected against sunlight. Encase the cycle lock in a plastic or foil packaging and store the cycle locks on palettes.

In order to keep the unused cycle lock operational for a period of up to six months, please observe the following storage conditions:

- the storage room should be dry and free of dust.
- the storage temperature should be between + 5°C to + 40°C.
- the storage should occur on a level ground.
- the cycle lock should be protected against unintentional movements or against tipping over and damages.
- encase the cycle lock in a plastic or foil packaging.

### D02 **Packaging**

The complete cycle lock from the EBRO ARMATUREN GmbH is packaged purposefully and securely depending on the transportation path and destination.

---

**INFO**



Note.

Once the delivery has reached its destination, the completeness of the delivery must be examined immediately based on the delivery papers and packaging lists as well as the intactness of the delivery.

In the event of complaints, the EBRO ARMATUREN GmbH must be informed immediately.

---

### D03 **General transportation**

The cycle lock will be - if nothing different is agreed upon - delivered completely assembled ex works by the EBRO ARMATUREN GmbH.

Please observe the specified weight and dimensions in the delivery papers from the system for transportation.

The cycle lock should be kept in its original packaging until usage or until assembly. The specified storage conditions must be complied with.

---

**HAZARD**

**Hazard through incorrect transportation or fastening.**



Severe damage to the cycle lock.

Do not suspend the cycle lock on the drive or moving drive!

Make sure that the folding discs and the flange seal surfaces on the fixtures are not damaged!

---



**D04 Transportation of the cycle lock with a fork lift**

Only transport the cycle lock with adequately equipped transportation and lifting equipment! Make sure it is securely mounted and avoid impact!

The cycle lock may be transported internally with a pallet truck or forklift. When transporting or moving the cycle lock, the center of gravity must be considered so that the cycle lock does not tip over or rock. When moving the cycle lock, the lifting height of the lifting equipment should be kept as low as possible. Furthermore, the safety guidelines for handling hand pallets or forklifts should be observed.

**HAZARD**

**Death hazard through transportation with forklifts**



If the load is improperly fastened or if the forklift is damaged, people may be injured or killed through falling loads.

Do not go in the moving and hazard area of the forklift!

Use permitted and inspected forklifts!

The driver must have a forklift license!

**D05 Transportation of the cycle lock with a crane**

Only transport the cycle lock with adequately equipped transportation and lifting equipment! Make sure it is securely mounted and avoid impact!

Furthermore, the cycle lock may be lifted and positioned with suitable lifting gear consisting of chains and hooks, or lifting belts, by crane. To do this, fasten your lifting gear sufficiently secure to the cycle lock and lift the cycle lock.

The safety guidelines for dealing with lifting gears (load handling equipment) and cranes should be observed.

**HAZARD**

**Death hazard through lifted loads**



If the load is improperly fastened or if the crane or lifting gear is damaged, people may be injured or killed through falling loads.

Do not go under lifted loads!

Use permitted and inspected load lifting equipment and cranes!

**D06 The lifting gear hitting the cycle lock**

Only transport the cycle lock with adequately equipped transportation and lifting equipment!  
 Screw in at least two sufficiently sized ring loops (pos. A) on a fixture (pos. B) from the cycle lock. Pay attention the weight of the delivered cycle lock.  
 Fasten your lifting gear on both ring loops.

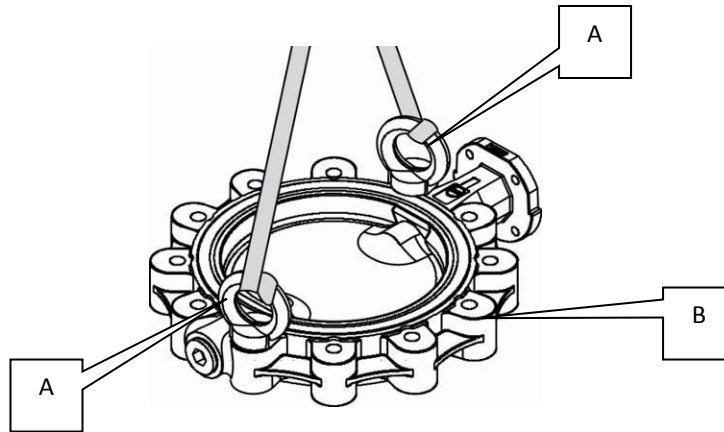

**HAZARD**

**Hazard through incorrect attachments.**



Severe damage to the cycle lock.  
 Use sufficiently dimensioned ring loops and mounts for attaching purposes.  
 Do not suspend the cycle lock on the drive or moving drive!  
 Make sure that the folding discs and the flange seal surfaces on the fixtures are not damaged!

## **E) Assembly manual**

### ***E01 Assembly of the cycle lock in a tubing system***

During the assembly of the cycle lock, the safety notes from this operating manual and the safety guidelines applicable at the setup location by the operator must be observed. The assembly location or installation location must have sufficient carrying capacity and should be free of vibrations.

The cycle lock should only be installed in an area that fulfills the requirements for the temperatures and surrounding conditions. The general directives for workplaces must also be complied with. Furthermore, observe the setup conditions in this operating manual.

The cycle lock is constructed and adjusted ex works for the purpose you ordered it for. This usage purpose thereby also corresponds to the proper usage of the cycle lock.

Before installation of the cycle lock, the proper usage must be compared again with the installation situation. Then it must be guaranteed that the installed cycle lock corresponds to the present pressures and media to be processed.

Installation in a tubing system must be approved by the operator and may only be executed by qualified staff.

The activation of the cycle lock is only permissible if it has been completely installed on both sides in a tubing system.

#### **HAZARD**

##### **Hazard through squeezing upper limbs.**



Severe injuries upon activating the cycle lock as long as it is not completely installed in a tubing system.

Before turning on the cycle lock, all components and connections must be completely assembled by qualified staff.

When installing the cycle lock, act with extreme caution and avoid damage to the components of the cycle lock. This applies in particular for the folding panels of the fixtures. Because a damage folding panel may lead to a leak in the fixture.

#### **CAUTION**

##### **Leak through damaged folding panel.**



The outer edge of the folding panel has a very fine design in order to guarantee that the fixture does not leak when the folding panel is closed.

That is why it must be guaranteed that this area is not damaged while handling during the installation process.

Make sure that the folding discs and the flange seal surfaces on the fixtures are not damaged!



The cycle lock must be installed between flanges according to EN 1092-1 or EN 1759-1. The seal strips according to Form A or Form B must be processed parallel to each other and aligned. This means that the ends of the two tubing sections must be aligned and have parallel connection surfaces. Through this, the usage of additional flange seals is not permissible, because the seal areas on the casing of the fixture are equipped with elastomer or polymer. This guarantees the sealing of the flange connections. A usage of a different flange or a different form of seal strip is not allowed. Should other flanges or forms be desired, these must be agreed upon with the EBRO ARMATUREN GmbH. The installation of these other designs must be confirmed in writing by EBRO ARMATUREN.

The clearance width of the counter-flange to the cycle lock must have adequate space for the opened folding panels so that these are not damaged when they are opened.

**INFO**

Note.



Observe the width of the counter-flange so that the opened folding panel has sufficient space.

Designs other than those named here must be agreed upon with the EBRO ARMATUREN GmbH.

Minimum required internal diameter $D_i$ of the counter-flange														
DN	50	65	80	100	125	150	200	250	300	350	400	450	500	600
$\varnothing D_i$	51	51	80	103	124	151	196	245	296	334	385	438	484	560

All internal areas of the fixtures must be free of contamination, in particular there may not be any hard or sharp particles here. This also applies to the tube sections to be connected on the construction side. The tube sections and the flanges must be clean and not have any damages.

**CAUTION**

**Leaking through contamination.**



Contamination in fixtures, flanges and construction-side tube sections must be removed.

Contamination that is not removed may lead to damage to the seal surfaces, this in turn leads to leaking.

Make sure that the contamination is removed in a proper manner!





The operator must therefore guarantee that the cycle lock and the tubing system are grounded through a secure grounder with a fixed grounding point. This applies in particular if insulating seals and screws made of non-conductive material are used.

The derivation resistance must be  $< 10^6 \Omega$ .

When using tubing materials that are not electrostatic conductive, the tubes must remain completely filled with medium and the escape speed from the tube may not exceed 1 m/s. The operator must guarantee that the cycle lock is connected through an electrostatic conductive tubing connection or through a separate grounding point.

**HAZARD**



**Life hazard through non-existent grounding in the explosive area.**

Severe injuries or death through explosion or fire.

During the assembly and operation of the cycle lock, it must be made sure that the cycle lock with all of its components and tubing system is grounded.

Ground cycle lock and tubing system through a secure grounding with a fixed grounding point!

**HAZARD**



**Life hazard through the non-compliance with the guidelines in the explosive area.**

Severe injuries or death through explosion or fire.

During the assembly and operation of the cycle lock, it must be made sure that the applicable guidelines, directives, etc. are complied with and observed so that sources of ignition are not created due to electrostatic charges!

Observe the guidelines and directives on the operator side!

## E02 Assembly of the cycle lock - steps during installation

The assembly of the cycle lock should be executed as follows:

- Unpacking of the cycle lock from the factory side packaging at the installation site.
- Examination of the cycle lock for transport damage.
- Examination of the cycle lock for damage, here the folding panels and the seal surfaces should be examined.
- Examination of the flanges from the cycle lock and the flange from the construction-side tubing system for dirt.
- Fastening of the cycle lock with corresponding lifting equipment according to this operating manual.
- Insertion of the cycle lock in an aligned manner and vertically in the construction side tubing system.
- Positioning of the cycle lock aligned between the two flanges (pos. A) of the construction side tubing system.
- Usage of all flange connections, make sure that the flange screws (pos. B) and nuts (pos. C) have sufficient dimensions. Only use fitting flange screws.
- Center all flange screws and tighten the flange screws crosswise. Observe the specified torque of the screws.

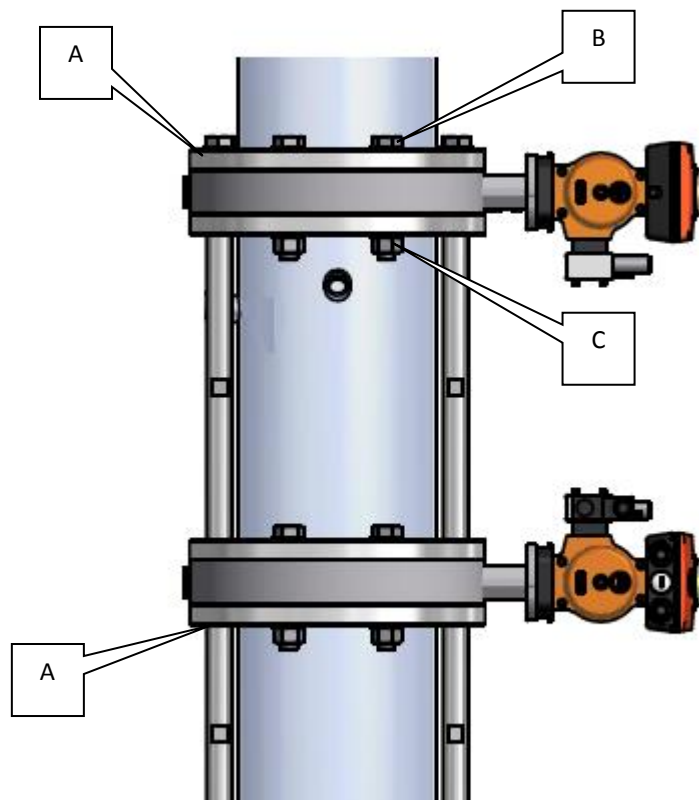

### E03 Assembly of the cycle lock as the end fixture of a tubing system

During the assembly of a cycle lock at the end of a tubing system where the one end of the cycle lock is no longer a part of a closed system, the assembly notes from Chapter E01 apply.

Additionally, it must be considered that a tube adapter must be attached at the open end of the cycle lock on the fixture.

This tube adapter must be at least 1000 mm long in order to avoid reaching the folding panel with the upper appendages when reaching into the tube adapter.

The flanging of the tubing system and the tube adapter is carried out as described in chapter E02.

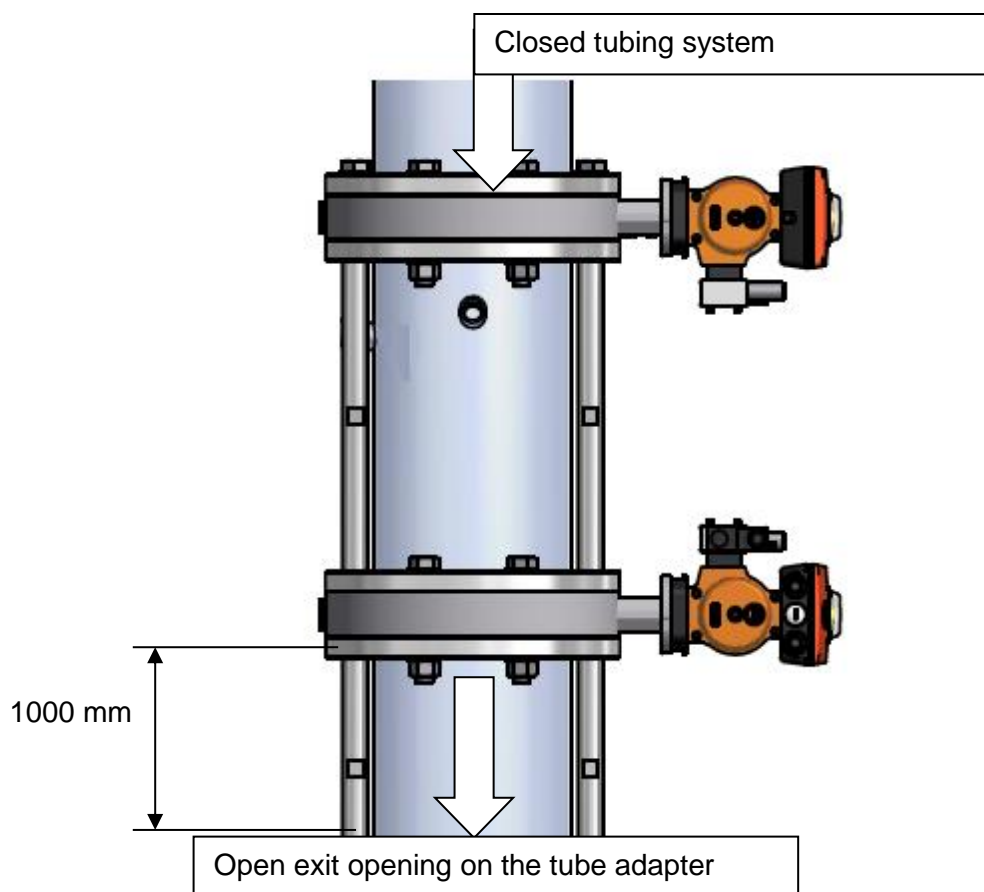

**HAZARD** Hazard through squeezing upper limbs.



Severe injuries when using the cycle lock as long as this was not equipped with at least a 1000 mm long tube adapter at the exit side during the design as a final fixture.

Before turning on the cycle lock, all components and connections must be completely assembled by qualified staff.



**E04 Connection of the electrical components**

The connection of the cycle lock should be turned off and secured against turning back on! Clamp the electrical lines in the control box and observe the clamp assignment in the circuit diagram. Close all connections in accordance with the legal regulations and according to the VDE directives. Make sure that the wire cross sections, fuses and outlets are sufficiently dimensioned and secured corresponding to the drive output. Metallic wire inlets must be connected with a grounding system. Drill holes that are not required for cable routes must also be closed through plugs. Connecting wire ends must always be done with suitable clamping tools in order to reach consistent quality of the pressing. All clamping positions, also those that are not used, must be tightened. If applicable, measures must be taken against external influences for cycle locks placed outside. This may be, for example, protective rain roofs or casings. The operator of the cycle lock is obligated to the inspection. The control unit of the cycle lock is integrated into the potential equalization through the external connection point for the potential equalization line, suitable for wires with 4 mm<sup>2</sup>. The potential equalization of the fixture is carried out for the tubing through a wire mounted on the fixture with 4 mm<sup>2</sup>, which keeps contact with the tubing with the help of the mounting elements. Only separate cable inlets suitable for usage were used for the wire feed. Connection threads from the switch casing that were not needed were locked with suitable separately permitted closing screws. The installation and maintenance may only be executed by an electrician, observe in particular the Safety chapter.

**HAZARD**

**Risk of death through electrical voltage.**



Severe injuries or death through electric shock.

The connecting of the cycle lock may only be executed by an electrician.

Establish a freedom of voltage and secure the cycle lock against being turned on again.

An electrostatic charge may be created through friction from the media and through the high pressures. This charge may influence and disturb the operation of the cycle lock. That is why there must be sufficient grounding of the cycle lock.

**WARNING**

**Disruptions to operation through electrostatic charge.**



Disruptions or damage to components.

The connecting of the cycle lock may only be executed by an electrician.

The cycle lock must be grounded.

The operator must therefore guarantee that the cycle lock and the tubing system are grounded through a secure grounder with a fixed grounding point. This applies in particular if insulating seals and screws made of non-conductive material are used.

The derivation resistance must be  $< 10^6 \Omega$ .

When using tubing materials that are not electrostatic conductive, the tubes must remain completely filled with medium and the escape speed from the tube may not exceed 1 m/s. The operator must guarantee that the cycle lock is connected through an electrostatic conductive tubing connection or through a separate grounding point.

**HAZARD**



**Life hazard through non-existent grounding in the explosive area.**

Severe injuries or death through explosion or fire.

During the assembly and operation of the cycle lock, it must be made sure that the cycle lock with all of its components and tubing system is grounded.

**Ground cycle lock and tubing system through a secure grounding with a fixed grounding point!**



### E05 Electrical customer connection

The components are already pre-wired. Only the wires for the voltage supply and the signal wires must be placed on the connection clamps X2 on the construction side. Observe the attached connection plan. Excerpt of external clamp assignment:

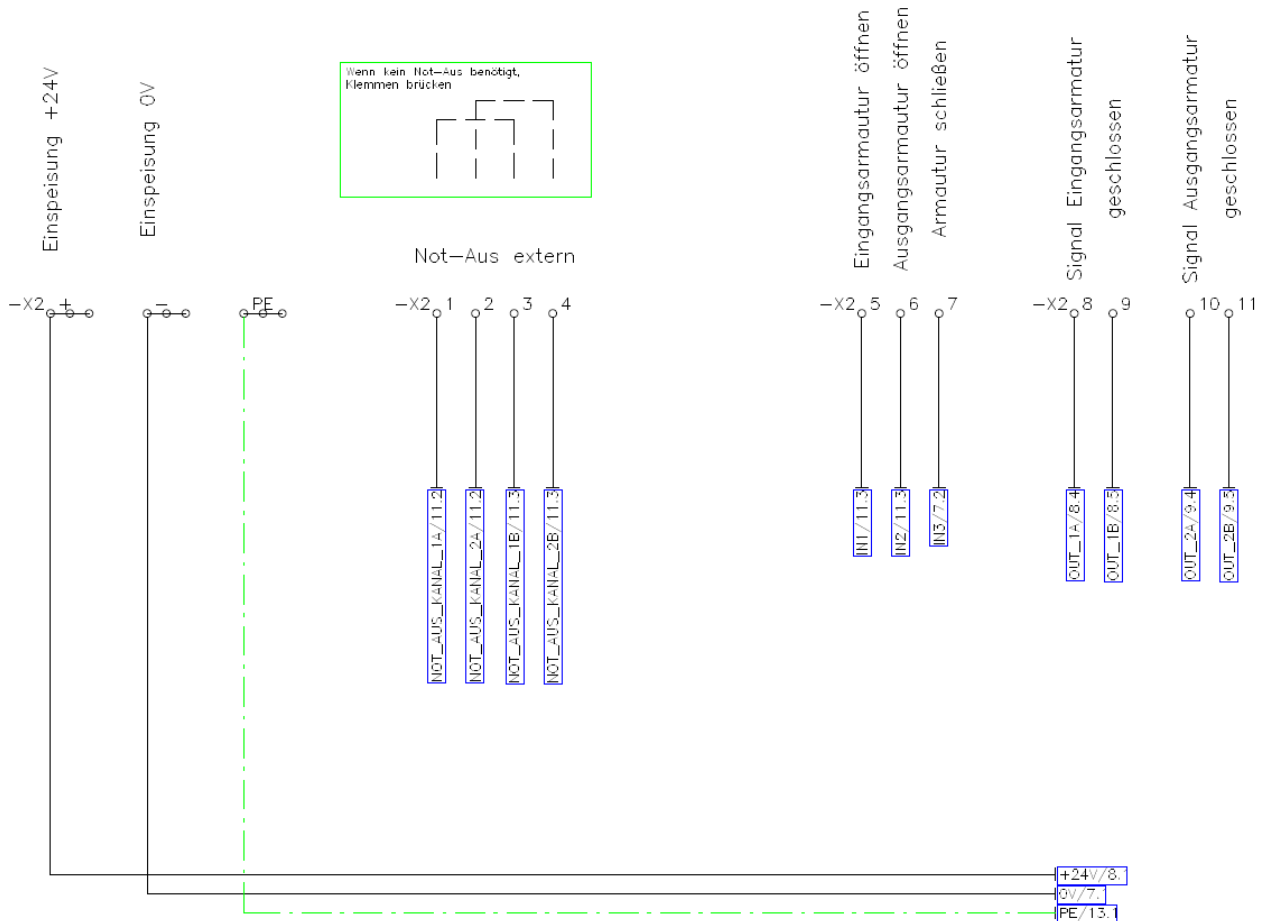

The emergency off is not bypassed ex works. If an emergency off button is needed depends on the customer application and must be defined by the operator. If an emergency off button is required, the clamps X2.1 to X2.4 must be connected with the two-channel emergency off circuit on the system side. If no emergency off is used, the clamps will be bypassed as shown. The function must be tested before commissioning.



**E06 Electrical customer connection - offset control box**

The components are pre-wired on one side. The connection wires from the control box to the components are connected in the control box and the wires are wound up on the control box during delivery.

These wires must be connected in the components according to the specifications of the attached connection plan. Only the wires for the voltage supply and the signal wires must be placed on the connection clamps on the construction side.

Observe the attached connection plan.

The emergency off is not bypassed ex works. If an emergency off button is needed depends on the customer application and must be defined by the operator.

If an emergency off button is required, the clamps X2.1 to X2.4 must be connected with the two-channel emergency off circuit on the system side.

If no emergency off is used, the clamps will be bypassed as shown.

The function must be tested before commissioning.

**E07 Controlling the cycle lock**

The cycle lock is only to be controlled through the clamp series X2

Accessing the internal wiring is not permitted.

Clamp assignment:

Clamp	Identification	Function
X2 +	+24V DC	Feed
X2 -	0V	Feed
X2.1	Emergency off external channel 1	With non-usage bridge after X2.3
X2.2	Emergency off external channel 2	With non-usage bridge after X2.4
X2.3	Emergency off external channel 1	-
X2.4	Emergency off external channel 2	-
X2.5	Input 1	Open incoming fixture (potential free contact,24V DC, impulse duration 400 - 800ms)
X2.6	Input 2	Open outgoing fixture (potential free contact,24V DC, impulse duration 400 - 800ms)
X2.7	Input 3	Close outgoing fixture (potential free contact,24V DC, impulse duration 400 - 800ms)
X2.8 and X2.9	Output 1	Response incoming fixture closed
X2.10 and X2.11	Output 2	Response outgoing fixture closed

The control may only occur as described in the signal diagram below. Controlling more than one input simultaneously is not permitted. The time between the controlling of two inputs must be at least 500ms.

**Signal assignment:**

On the clamp series X2 above, it must be guaranteed through the external control that only signal combinations from the following figure are present. A deviating control is not permissible and must be guaranteed through corresponding locking (for example, in the SPS software).

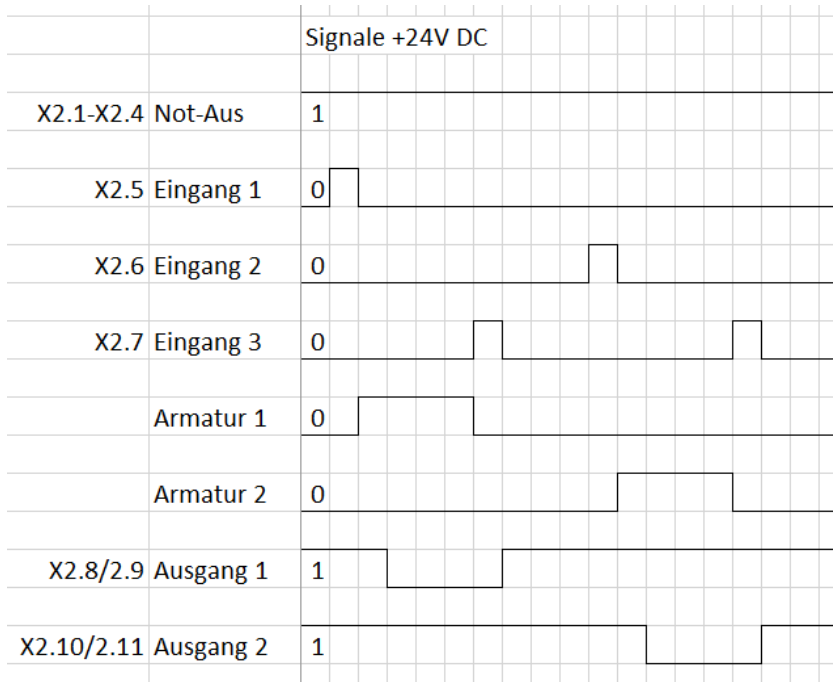





**E08 Connection of the pneumatic components**

Connect the compressed air wire to the hose connection.

The drive must be adjusted to the fixture with its drive torque and characteristic curve and the setting of the fixture must be displayed correctly with its optic displayed. Since the drive from the cycle lock is equipped with a switch box, the display of the position is carried out through the switch box.

The drives were installed for the delivered cycle lock and adjusted to the respective fixture. They may not be changed. A usage of other components is not seen as proper. Should other components of the drive be desired, these must be agreed upon with the EBRO ARMATUREN GmbH. The installation of these other designs must be confirmed in writing by EBRO ARMATUREN.

The drives are normally operated with compressed air or a different control medium in a gas state. Moreover, the control medium must have a dew point that corresponds to -20°C or is at least 10°C below the surrounding temperature.

The compressed air used must be filtered with a filter with a 40 µm mesh size in order to protect the magnet valve. The compressed air must be dried and should be slightly greased with switch cycles of ≥ 4 x/min.

Set the pressure to **6 bar**.

The entire pneumatic system is designed for operation with dry or slightly greased air.

A correctly connected drive normally must be closed clockwise when looking at the drive shaft of the fixture and opened in the opposite direction.

**HAZARD**

**Hazard through uncontrolled starting pneumatic components.**



Severe injuries with incorrectly connected pneumatic components or for pneumatic components that start without being controlled.

The pneumatic components may only be connected by a specialist.

All components and connections must be examined before turning on the pneumatic system.

**HAZARD**

**Hazard by exceeding the maximum pressure.**



If the maximum pressure specified on the drive is exceeded, this may lead to property damage to the components of the cycle lock.

Check the compliance with the specified pressures.

**HAZARD**

**Hazard through squeezing upper limbs.**



Severe injuries upon activating the cycle lock as long as it is not completely installed in a tubing system.

Before turning on the cycle lock, all components and connections must be completely assembled by qualified staff.



The compressed air supply from the cycle lock must be provided by the construction side. The compressed air required for the pneumatic mobile drives must be extracted and provided outside of the ex-area from the surrounding air. Here it must be made sure that the fed compressed air does not contain any components or particles that may contribute to an explosion risk. Furthermore, it must be guaranteed that an impermissible heating up of the fed compressed air cannot lead to an increase in temperature that would be above the maximum permissible surface temperature.

**HAZARD**



**Deathly hazard through components or high temperatures from the compressed air in the explosive area.**

Severe injuries or death through explosion or fire.

When operating the cycle lock, it must be made sure that the compressed air does not represent an explosion hazard, whether it is through components or high temperatures in the compressed air.

An electrostatic charging of existing plastic hoses cannot be ruled out through the friction of condensation on the inner walls of the hose, in connection with the flowing compressed air. These charges may lead to a hard, if there is accidental discharge, which is why they must be avoided. The operator must guarantee that the maintenance unit is always observed and the water collected here is emptied in regular intervals. Solid parts that are located within the compressed air and move along the inner wall of the hose may also lead to electrostatic charges.

The operator must make sure that a fine filter is installed at suitable spots. A suitable spot for the fine filter would be at a place before the compressed air passes the plastic hose.

Qualified staff must guarantee that the data from the cycle lock about the control pressure, control voltage and frequency agrees with the technical data notes on the respective signs from the components.

The compressed air line leading to the magnetic valve should be designed as follows as a non-binding recommendation:

Size	EB4.1	EB5.1	EB6.1	EB8.1	EB10.1	EB12.1
Volume / lift of the drive (liter)	0.18	0.46	0.91	1.49	3.25	5.63
Recommended wire - Ø (up to 6m long)	6 mm	6 mm	6 mm	6 mm	8 mm	8 mm

Control diagram for single working drives with spring reset EBx.1 SYS:

For the single-working, spring resetting drives, the addition of the control medium must be carried out through the connection on the left.

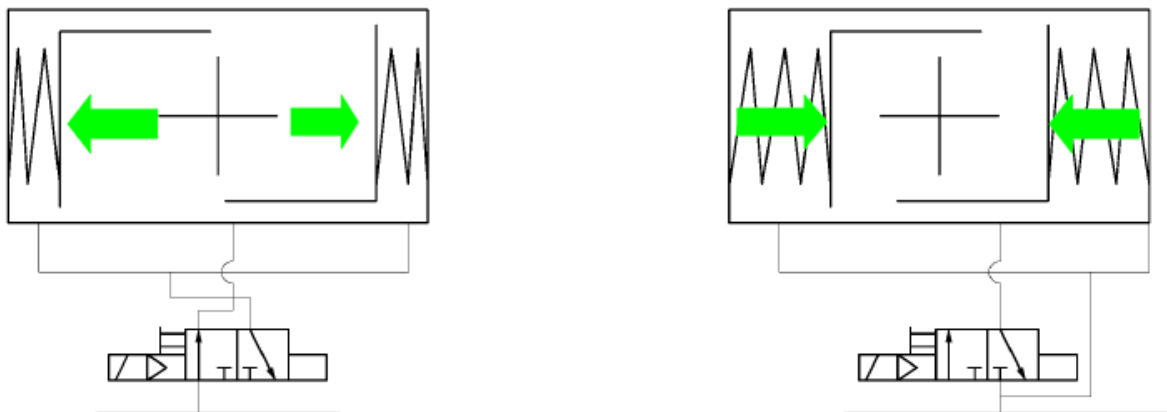

**HAZARD**



**HAZARD**

Only single-acting actuators with fail-safe action CLOSED may be used for a cycle lock as Ex decoupling.

### E09 Connection of the pneumatic components - steps connection drive

The connection of the drive should be executed as follows:

- Examination of the drive for transport damage.
- Examination of the drives for damage, in particular the casing must be examined here.
- Screw off the coupling nut (pos. A) from the respective hose guide (pos. B).

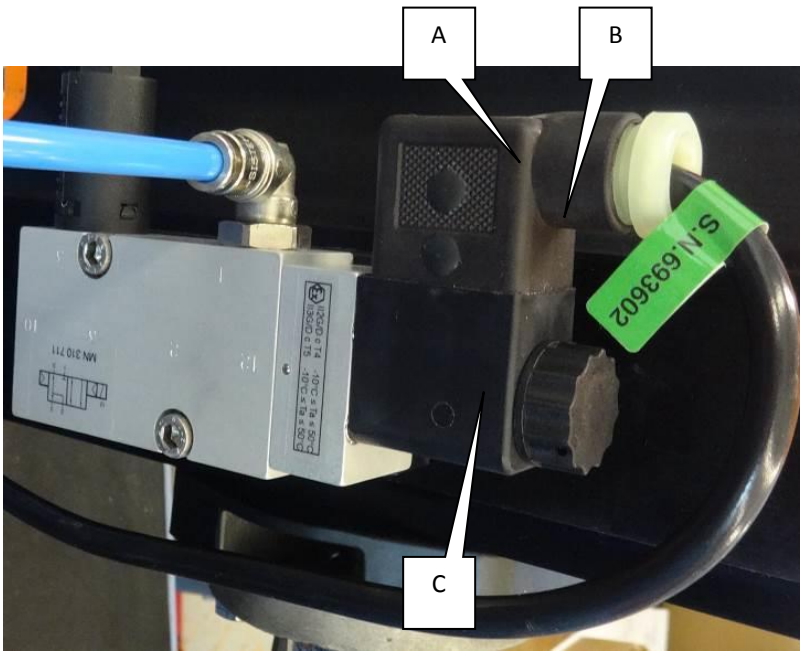

- Slide the coupling net in a correct position on the compressed air wire so that you can connect the hose inlet again at a later point in time.
- Guide the compressed air lines through the feeds into the magnetic valve (pos. C).
- After connection, check all compressed air lines for leaks.
- Screw tight the coupling nut on the respective hose guide.



### E10 Disassembly of the cycle lock

During the disassembly of the cycle lock, the safety notes from this operating manual and the safety guidelines applicable at the setup location by the operator must be observed. Removal from a tubing system must be approved by the operator and may only be executed by qualified staff.

When removing the cycle lock, act with extreme caution and avoid damage to the components of the cycle lock and on the tubing system.

The disassembly of the cycle lock should be executed as follows:

- Stop the cycle lock, release it and secure it against turning on again!

**NOTE**



Release cycle lock and secure against turning on again with a lock.

Release electrical components and cycle locks for all work, before maintenance, during adjustment and maintenance and secure against turning on again.

Release the pressure for all work on pneumatic components and cycle locks and secure against pressure.

**HAZARD**

**Risk of death through electrical voltage.**



Severe injuries or death through electric shock.

The connecting of the cycle lock may only be executed by an electrician.

Establish a freedom of voltage and secure the cycle lock against being turned on again.

**HAZARD**

**Hazard through uncontrolled starting pneumatic components.**



Severe injuries with incorrectly connected pneumatic components or for pneumatic components that start without being controlled.

The pneumatic components may only be connected by a specialist.

All components and connections must be examined before turning on the pneumatic system.

**HAZARD**

**Life hazard through the non-compliance with the guidelines in the explosive area.**



Severe injuries or death through explosion or fire.

During the assembly and operation of the cycle lock, it must be made sure that the applicable guidelines, directives, etc. are complied with and observed so that sources of ignition are not created due to electrostatic charges!

Observe the guidelines and directives on the operator side!

- Make sure that the tubing system is released for removal from the cycle lock by the operator.
  - Make sure that the tubing system and the cycle lock are completely emptied.
  - Make sure that the tubing system and the cycle lock are completely free of pressure.
  - Make sure that the electrical components of the cycle lock are free of electricity.
  - Make sure that the pneumatic components of the cycle lock are free of pressure.
  - Be informed about the safety guidelines at the place of disassembly. If you have to execute welding or grinding work, you must obtain a welding and grinding permit, a so-called welding permit, from the operator in advance.
- 
- Find out sufficiently about the media used in the tubing system and in the cycle lock. Make sure that you obtain the important information from the operator and from the different safety specifications for hazardous substances. You may not start with the disassembly before you have these specifications.
  - Use the personal protection equipment (PPE) prescribed for the hazardous substance while disassembling the cycle lock.
  - Clean and neutralize all components coming into contact with the media before processing further after disassembly. If necessary, decontaminate these components.

**CAUTION**      **Hazard through operating or hazardous substances or through media.**



Severe injuries or damage to the cycle lock.

The safety specifications from the operating and hazardous substances must be present and observed.

Use the personal protection equipment required in the safety specifications when handling the respective hazardous substance.

- Move the two flaps from the fixtures to the CLOSED position so that both flaps are completely closed.
- Unscrew the coupling nut on the hose inlet from the compressed air feed.
- Remove the compressed air wire from the cycle lock.
- Secure the cycle lock from sliding, tipping or falling down with the corresponding lifting equipment. Pay attention to the weight of the cycle lock and in particular the chapter about fastening lifting equipment.

**HAZARD**      **Hazard through incorrect attachments.**



Severe damage to the cycle lock.

Use sufficiently dimensioned ring loops and mounts for attaching purposes.

Do not suspend the cycle lock on the drive or moving drive!

Make sure that the folding discs and the flange seal surfaces on the fixtures are not damaged!



- Unscrew all flange connections and remove the screws and nuts from the cycle lock.
- Force apart the flange from the cycle lock and the tubing system with a corresponding tool.
- Remove the cycle lock from the tubing system. When removing the cycle lock, you must make sure that the flange seal areas of the cycle lock and the tubing system are not damaged. If necessary, protect the seal areas from damage.

---

**CAUTION**

**Leak through damaged folding panel or seal areas.**



The outer edge of the folding panel has a very fine design in order to guarantee that the fixture does not leak when the folding panel is closed.

That is why it must be guaranteed that this area is not damaged while handling during the removal process.

Make sure that the folding discs and the flange seal surfaces on the fixtures and on the tubing system are not damaged!

---

## F) Test run after installation

### F01 Test run

The delivered cycle lock was manufactured, set and examined ex works for the technical data specified in the order.

Nevertheless, you have to guarantee the proper function for automatic operation after complete installation of the cycle lock. That is why you should execute and document the following steps before commissioning. It is important that you always execute these steps on both drives and fixtures.

- Check if all components and connections were correctly installed.
- Check the correct installation of the cycle lock in the tubing system.
- Check the programming or control of the cycle lock for functionality.

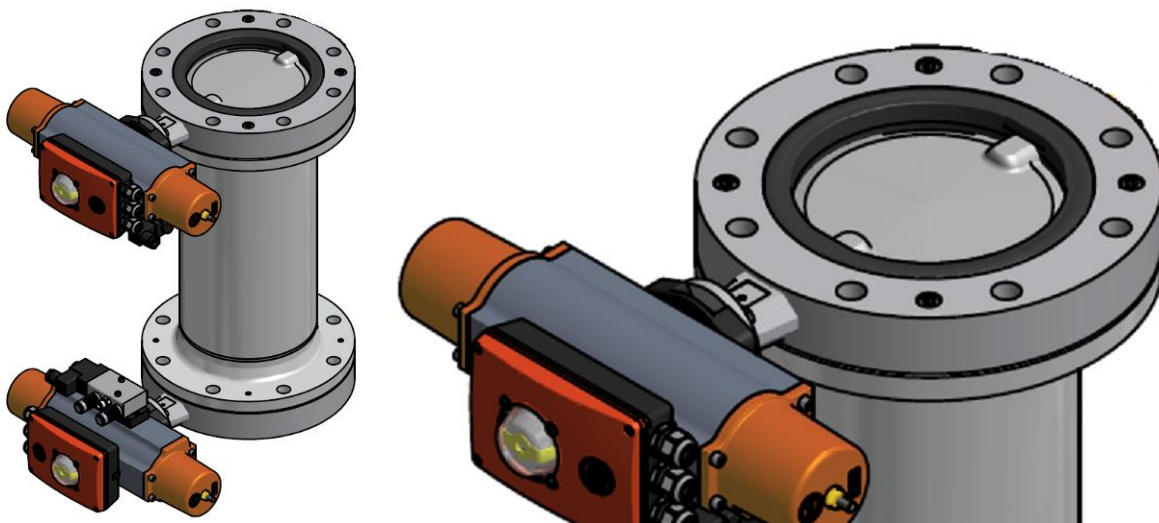

#### HAZARD

#### Hazard through incorrect setting or display.



Severe damage to the cycle lock during operation.

An incorrect display or response represent a hazard.

Make sure that the settings OPEN or CLOSED from the fixtures agree with the control.

#### INFO

Note.



Pay attention to the setting and display of the fixture and drive.

A setting of the limit stop CLOSED from a new cycle lock should not be changed as long as the fixture is sealed.

Please observe the notes in this operating manual for adjustment.



- Check the control pressure immediately on the magnet valve. This must have an adequate size. At least the control pressure must be present here that is marked on the sign from the drive. Only then can a smooth operation of the fixture be guaranteed under operating conditions.
- Check the correct connection of the magnetic valve. With pending control pressure and with a failure of a control signal (to examine, for example, remove the plug), the fixture must be moved to determined setting "CLOSED". If a different setting of the fixture is desired, this must be discussed with the EBRO ARMATUREN GmbH. If the fixture does not move to the "CLOSED" setting, the activation and/or the switching of the magnetic valve must be corrected correspondingly.

Drive type	Type sign	Fixture must
spring closing	EB X.1 SYS	move to the "CLOSED" safety setting.

- Check the screw connections between the drive and fixture with a torque wrench. Observe the corresponding torque for this.
- Check the flange connections between the tubing system and cycle lock with a torque wrench. Observe the corresponding torque for this.
- Check the grounding of the cycle lock.
- Turn on the cycle lock and execute a test run. Make sure that with pending control pressure, the respective fixture is moved into the designated final position with the corresponding control commands "OPEN" and "CLOSED".

**HAZARD**



**Life hazard through non-existent grounding in the explosive area.**

Severe injuries or death through explosion or fire.

During the assembly and operation of the cycle lock, it must be made sure that the cycle lock with all of its components and tubing system is grounded.

Ground cycle lock and tubing system through a secure grounding with a fixed grounding point!



## F02 Pressure check

The delivered cycle lock was manufactured, set and examined ex works for the technical data specified in the order.

All delivered cycle locks were subject to a seal and completion inspection from the manufacturer ex works.

For the pressure check of a cycle lock in a tubing system, the testing conditions from the tubing section apply - but with the following restrictions:

- The test pressure from a cycle lock may not exceed the value of 1.5x PS (according to the sign).
- If a closed folding panel is subject to more than 1.1x PS, the risk exists that the inner parts of the fixture are over-stressed. This must definitely be avoided.

---

### HAZARD

**Hazard through test pressures being too high during the pressure check.**



Severe damage to the cycle lock.

Make sure that during the pressure check the two folding panels from the cycle lock are opened.

Make sure that the test pressure does not exceed the value of 1.5 x PS.

---



## **G) Product description**

### ***G01 Proper usage***

The cycle lock from the EBRO ARMATUREN GmbH is only designed to deliver and dose media from silos, containers, hoppers, etc. Compared to the standard version, no optional bypasses are intended for the safety version in order to bypass possible pressure levels.

The cycle lock is delivered corresponding to the order from the operator as a completely inspected unit ready for installation.

The cycle lock normally consists of two fixtures, two flexible drives, a filling tube and a control from the EBRO standard portfolio.

The safety version for usage in explosion hazard areas is equipped with components for locking, which establish and monitor the functional safety.

The cycle lock can be installed permanently in explosion hazard areas from zone 1, zone 21, zone 2 and zone 22.

The zone in the tubing, different from the surrounding environment, may be a maximum of zone 0 or zone 20.

The cycle lock is an incomplete machine, which is set for the installation in a tubing system or an attachment to a silo, container or similar system.

The manufacturer of complex cycle lock in which the cycle lock is installed is obligated to create a risk assessment for this complex cycle lock. In particular the interfaces to the cycle lock components or the cycle lock must be observed here. If due to this observation it is necessary to install further protective equipment for the complex cycle lock, this occurs in the responsibility of the manufacturer of complex cycle locks.

The cycle lock may only be operated with the accessories, which are designated and approved for this by the EBRO ARMATUREN GmbH.

The specifications in the Technical Data sub-chapter as well as in the original documentation from the supplier products in the attachment must be observed and complied with.

Another different or excessive usage is not seen as proper.

Only the operator of the cycle lock is responsible for any damage resulting from this. This also applies to independent changes to the cycle lock.

The proper usage includes compliance with the notes on safety, operation and maintenance and repair, which are described in this operating manual and in the documentation from the supplier products.

The following applies to cycle locks:

- the cycle lock is solely used to transport, dose or provide media that corresponds to the technical requirements from this operating manual.
- the cycle lock is only used to operate the media confirmed and approved by the EBRO ARMATUREN GmbH.
- the media must be visible from the order.
- any other usage of the cycle lock, for example, the processing of other media and the processing of unapproved media, is seen as improper.
- the usage of the cycle lock in areas with cycle lock hazards is permissible.
- is only to be used for the purposes confirmed by EBRO ARMATUREN GmbH and operated only under the usage conditions prescribed in this operating manual.

- is only to be operated with the settings and variations prescribed in this operating manual.

Independent constructional changes, attachments or changes to the cycle lock without written consent from the manufacturer, as well as changes and modifications in the electric system or the control and settings are forbidden or must be agreed upon in advance with the EBRO ARMATUREN GmbH.

---

HAZARD

Hazard through improper usage of the cycle lock



In the event of improper or illegal usage of the machine, people may be severely injured or killed. Furthermore, the cycle lock may also be damaged.

Only use cycle locks properly!

Do not make any changes to the cycle lock!

---

INFO

Observe all notes in this operating manual, in particular the safety notes. They must be read and observed before all activities on the cycle lock.



Any other usage, setting and variation compared to what is described in this operating manual is seen as illegal and as an improper use of the cycle lock!

---

HAZARD

Life hazard through the non-compliance with the guidelines in the explosive area.



Severe injuries or death through explosion or fire.

During the assembly and operation of the cycle lock, it must be made sure that the applicable guidelines, directives, etc. are complied with and observed so that sources of ignition are not created due to electrostatic charges!

Observe the guidelines and directives on the operator side!

## G02 Scope of delivery

The cycle lock was designed and created at EBRO ARMATUREN and is suitable for delivering and dosing suitable media from silos, containers, hoppers, etc.  
The cycle lock we deliver as an incomplete machine is designated for installation in a tubing system. It consists of:

- two fixtures (Pos. A).
- two mobile drives (Pos. B).
- a filling tube (Pos. C).
- optionally PLC control unit (Pos. D).
- optionally level sensor (installed in the filling tube)
- Operating and assembly manual.
- Conformity statement and sample permit.

Immediately after receiving the cycle lock, check to see if it agrees with your order and if all components are complete.

Report:

- Recognizable transportation damages immediately to the deliverer.
- Recognizable defects or incomplete orders immediately to the EBRO ARMATUREN GmbH.

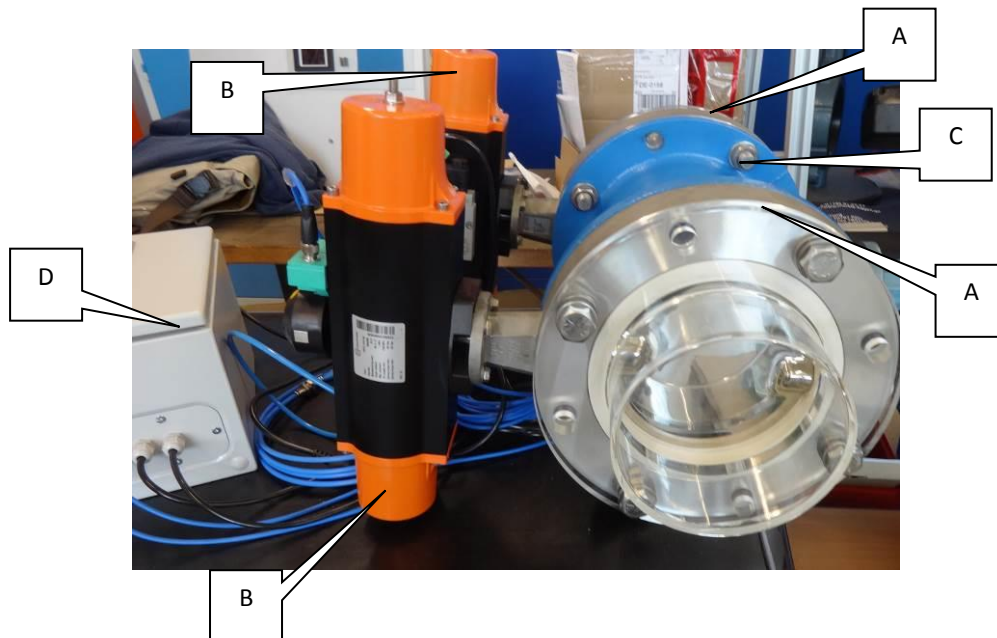

### G03 Description of the components

The cycle lock in the safety design consists of two fixtures (pos. A), two mobile drives (pos. B), a filling tube (pos. C) and a control (pos. D).

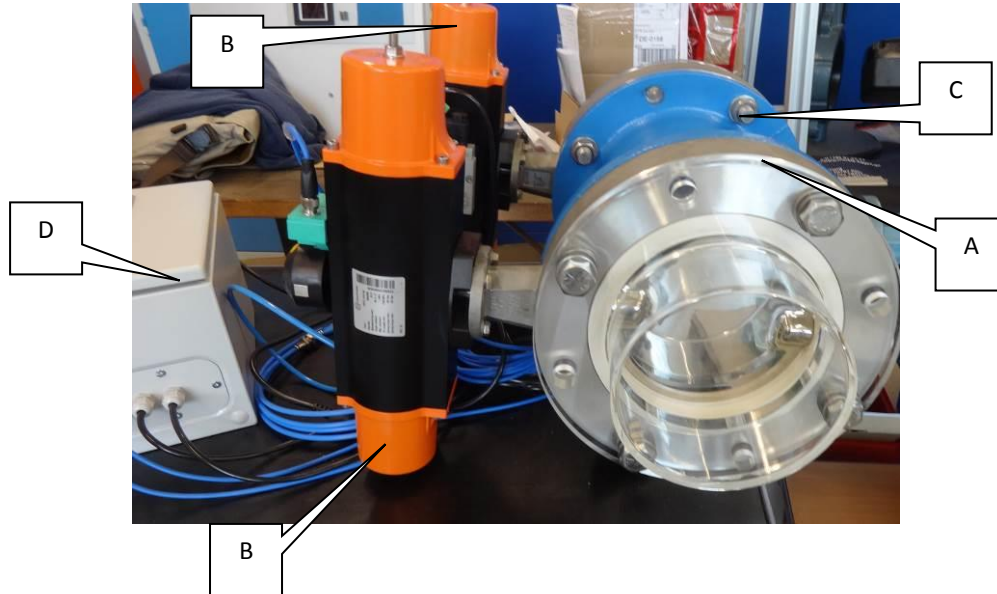

- Pos. A) Block fixture - any fixture from the EBRO portfolio may be used here if there is technical proof of the ignition safety and explosive resistance according to DIN EN 14460. The fixture can, for example, be a block flap, a spacer, a squeeze valve or a ball valve. The block fixture is screwed with the filling tube.
- Pos. B) Mobile drive - any pneumatic mobile drive from the EBRO portfolio can be used here. The pneumatic mobile drives are based on a conformity evaluation procedure in accordance with 94/9/EC, attachment VIII, module: Internal production Control. The drives are identified in accordance with 94/9/EC for usage in explosion areas (ATEX). The mobile drive is mounted on the block fixture.
- Pos. C) Filling tube - a standard filling tube or a filling tube according to the customer's request is used here. The filling tube may also, for example, have a conical shape. The volume of the filling tube is dependent on the height and diameter of the filling tube. The filling tube is designed analog to the fixture with an explosion resistance according to DIN EN 14460.
- Pos. D) PLC – consists of a control unit with the visualization through a touch panel. The operation and visualization are carried out through the control of the PLC. Here all process values and times can be set as desired. The PLC has a web visualization, which provides the entire scope of function of the touch panel, for example, in the customer network.

### G04 Functional process of the cycle lock

For the cycle lock in the safety version, the steps occur as follows:

#### 1. Basic setting from the cycle lock

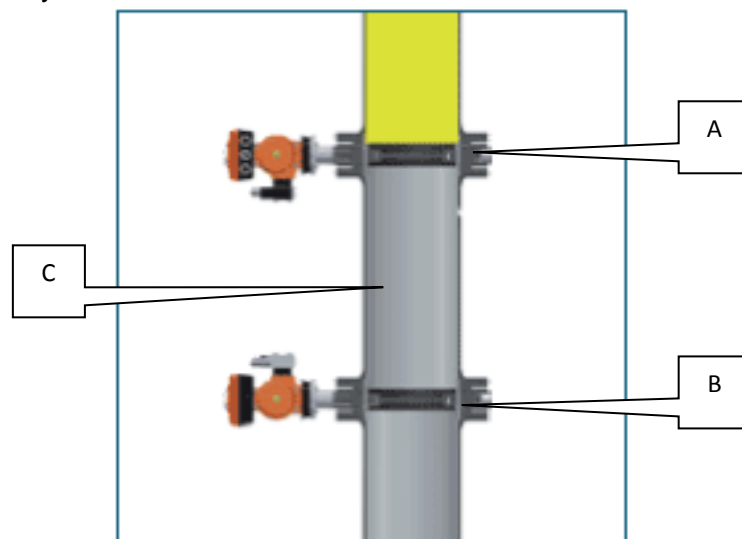

- Blocking of the medium in the tubing system through the incoming fixture (pos. A).
- Opening of the outgoing fixture (pos. B). This process is executed before every single sequence and makes sure that any remaining medium in the filling tube (pos. C) is delivered out of the filling tube.
- Close the outgoing fixture.

#### 2. Filling the filling tube

- Open the incoming fixture. Through this, the medium moves into the filling tube and is kept in the filling tube through the closed outgoing fixture. The filling time can be adjusted as desired. The fill quantity depends on the set time for filling, the form and size of the filling tube, the pressure and the medium.

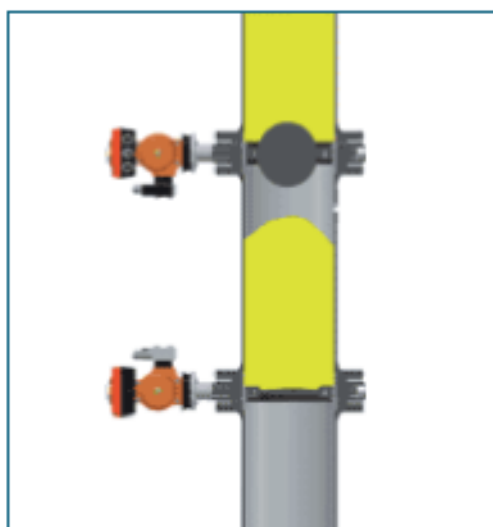

3. Intermediate position

- Close the incoming fixture after reaching the set time. The medium is kept in the filling tube until the outgoing fixture opens or the waiting time has expired.

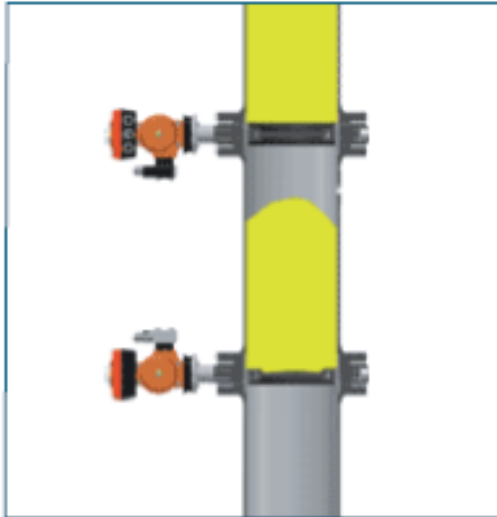

4. Emptying

- Open the outgoing fixture to empty the filling tube. Through this, the medium is transported from the filling tube to the continued process.
- Close the outgoing fixture. After this, the next sequence can be executed.

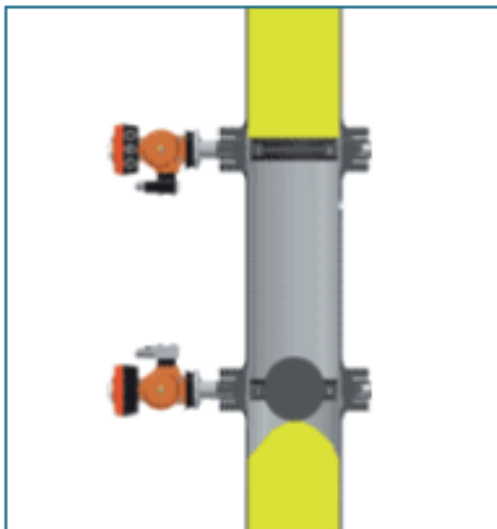



### G05 Functional process of the locking

The end position switches are designed as inductive proximity switches.  
Exemplary illustration:

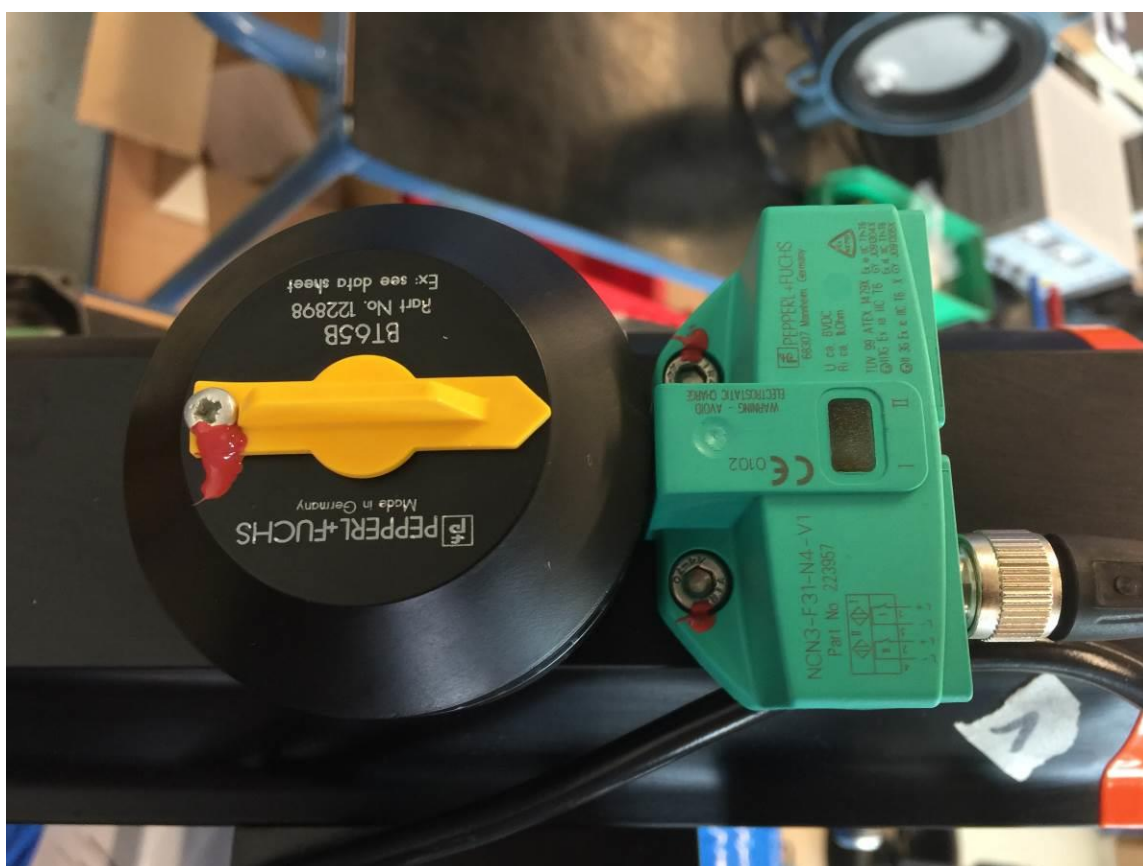



### **G06 Software technical locking**

Independent of the operating mode and the external signal states, all fixtures are locked with each other through locking components. Plus there is a dead time that delays the opening of a fixture after it has been successfully closed.

### **G07 Safety setting**

There is an emergency off command input. This signal is used internally to immediately stop all processes and shutting down of all outputs.

Since the actual EMERGENCY OFF function is realized through the SPS external safety relay and the outputs of the SPS only reset this safety relay, the control is not safety relevant.

## H) Operation and visualization

### H01 *General note on operation*

Before beginning operation, read the chapter *Safety Notes*. The listed safety notes must be followed and are valid for all sub-chapters. Also observe the information from the connected processing cycle lock, the tubing system and that of the programming.

---

**HAZARD****Risk of death through electrical voltage.**

Severe injuries or death through electric shock.

The connecting of the cycle lock may only be executed by an electrician.

Establish a freedom of voltage and secure the cycle lock against being turned on again.

**HAZARD****Hazard through uncontrolled starting pneumatic components.**

Severe injuries with incorrectly connected pneumatic components or for pneumatic components that start without being controlled.

The pneumatic components may only be connected by a specialist.

All components and connections must be examined before turning on the pneumatic system.

### H02 *Operating setup on the touch panel*

The cycle lock is equipped with a main operating console, which is located in a separate control box. This can be installed directly near the cycle lock or also at a short distance from the cycle lock. Furthermore, the control in a customer-side SPS can be integrated through binary signals or field buses. The operating console serves for the operation and setting of the parameters from the cycle lock. It is equipped with a touch panel. Through this, commands can be entered directly through the screen. Use the included stylus or your finger to touch the screen.

In order to be able to understand the operation of the cycle lock on the interface - operator and cycle lock - as easily as possible, the control is divided by a functional menu structure. Here you can change from the main view of the screen to the different menu levels by clicking on the desired menu points through the buttons. The selection options and assignments are displayed on the screen for you.

### H03 Main screen

In the upper left frame, you will find the operating mode selection.

If the cycle lock is in automatic mode, it can be remotely controlled through external commands. If "automatic" is deselected, it will be in manual mode.

The current status is displayed in the lower left frame.

The status is either green or red. Green means that the cycle lock is ready for operation or in operation. In clear text, "Ready" (ready for operation) or "In Progress" (the cycle lock is currently running either in manual or automatic mode) is found next to this.

If the status is red, a disruption is present. In this case, a switch button to get to the error message window will show up under the status message.

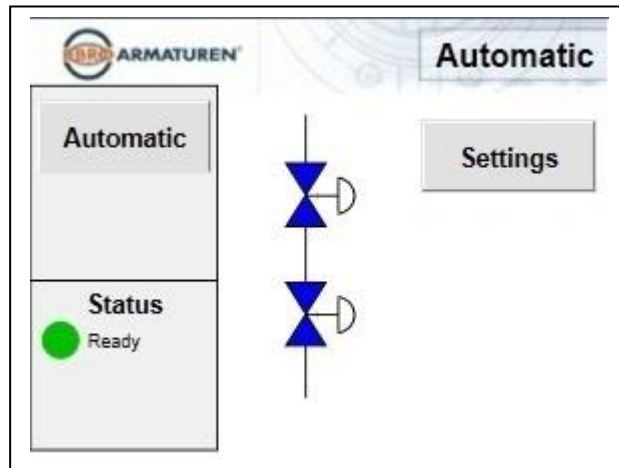

### H04 Set up screen

The access is password protected and the "automatic" operating mode must be disabled. By entering the correct password and selecting the "login" button, you can get to the overview by pressing "Next".

The following actions can be executed in the "Settings" program area:

- Manual operation (on site operation).
- Parameter settings (for example, activation times for all fixtures in the automatic mode).
- Observation of the process values.

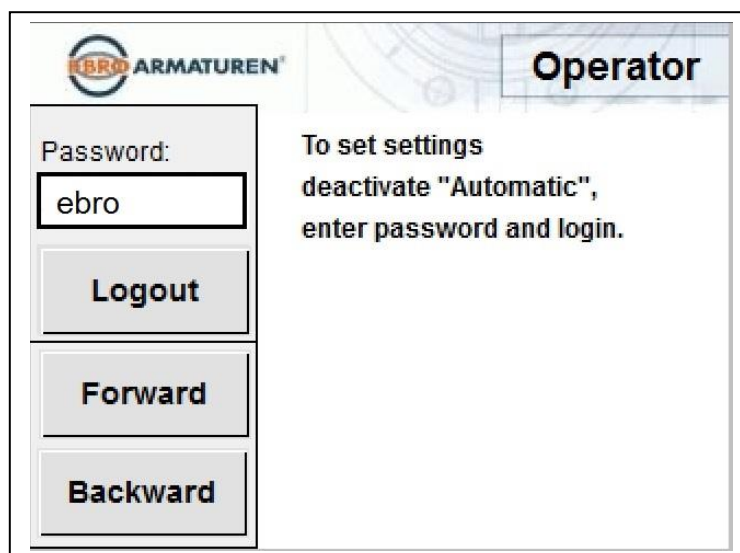
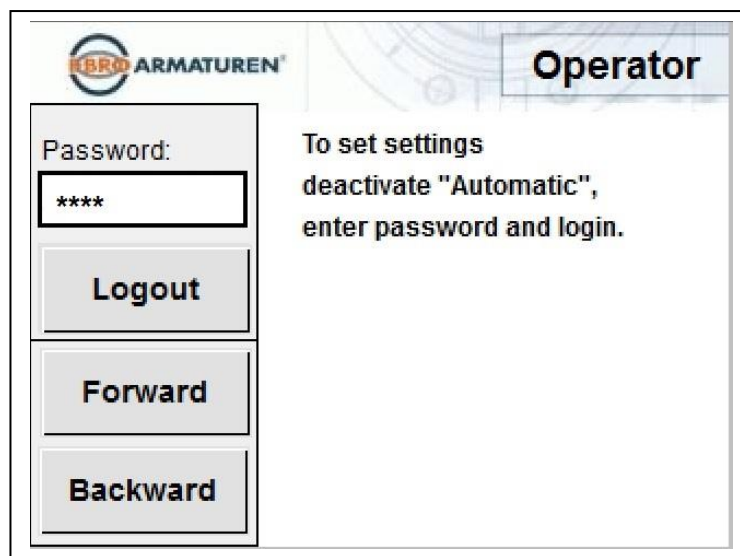

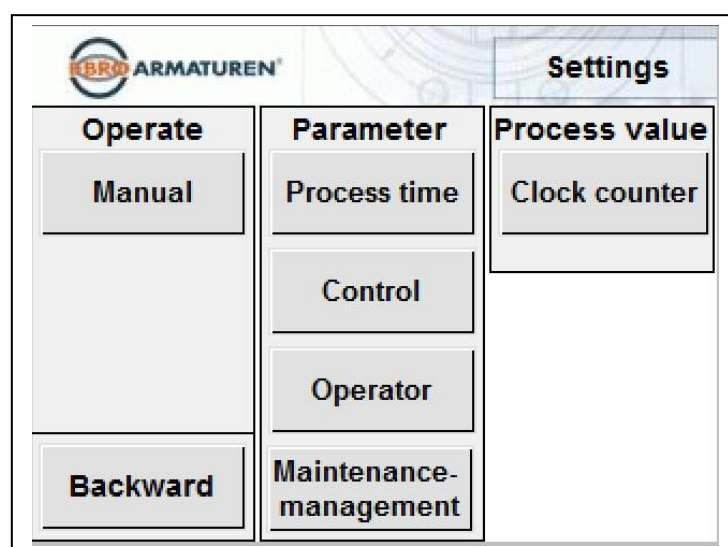
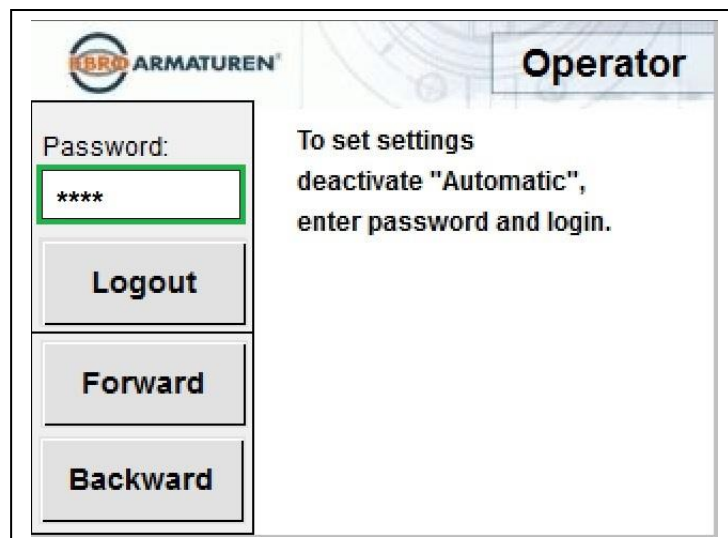

**H05 Manual screen**

In manual mode (on site operation), individual sequences can be executed or the cycle lock can be filled or emptied separately. In addition to this is a completely manual operation of the individual fixtures by making the selection in the image representation. The respective fixture is opened by clicking on it once. If the button is deselected, the fixture will close.

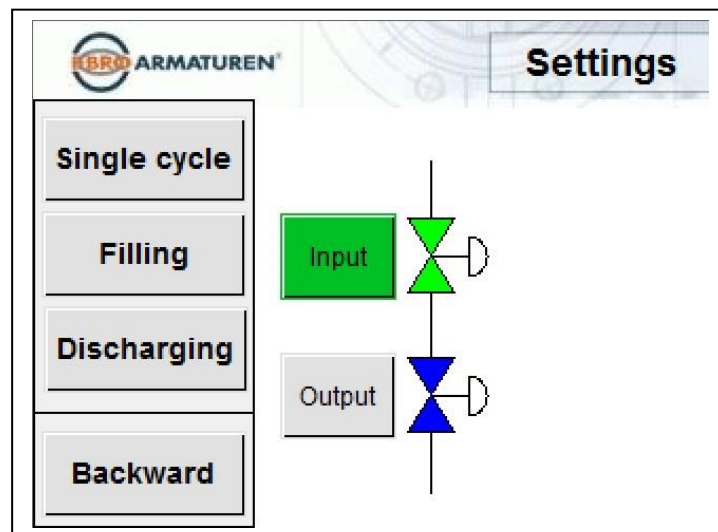
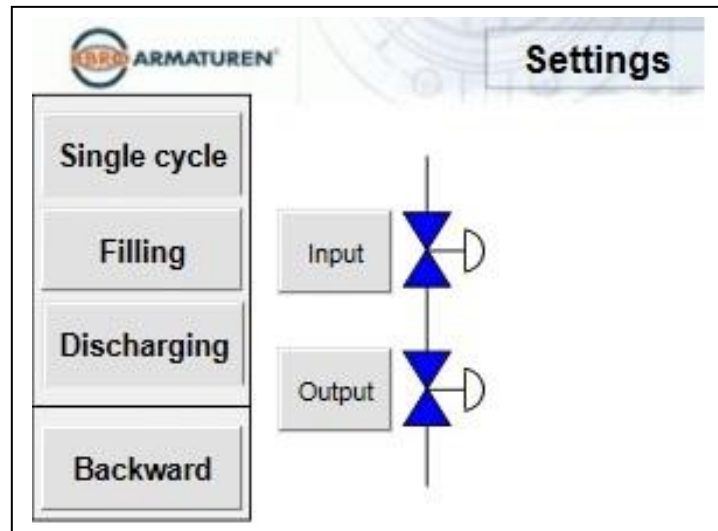

**H06 Process times screen**

Explanation:

Parameter	Description	Unit	Default
<i>Time filling</i>	Time of how long the input fixture is opened to fill the intermediate tube piece.	1,000 ... 100,000 ms	2,000 ms
<i>Idle time</i>	Idle time for the material in the intermediate tube piece before delivery.	0 ... 100,000 ms	400 ms
<i>Time discharging</i>	Time of how long the input fixture is opened to empty the intermediate tube piece.	1,000 ... 100,000 ms	2,000 ms
<i>Repetition time</i>	Repeat time from when the next cycle is to begin ( for continuous signal)	0 ... 100,000 ms	60,000 ms
<i>Total run time</i>	Sum of all process times listed above, including internal delay times.	ms	-

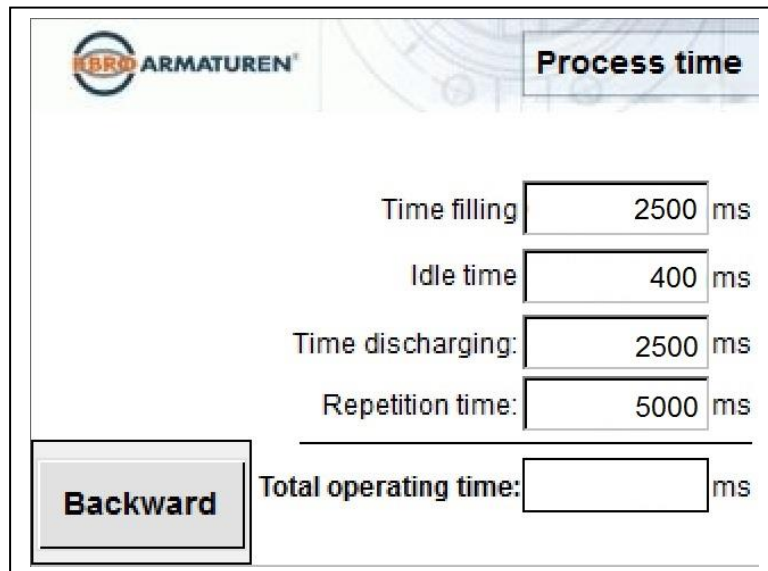

**EBRO ARMATUREN®** **Process time**

Time filling  ms

Idle time  ms

Time discharging:  ms

Repetition time:  ms

---

Total operating time:  ms





**H07 Control screen (Other value)**

Explanation:

Parameter	Description	Unit	Default
<i>Delay fault indication</i>	Delay time between the "normal" operating states and the classification of faulty states as an error.	0 ... 100,000 ms	2,000 ms
<i>Mutual locking</i>	Dead time between two activations of different fixtures.	1,000 ... 100,000 ms	2,000 ms
<i>Max. allowed runtime</i>	Upper limit for the duration of the individual cycles. This value is defined by the total process of the cycle lock and must be entered by the customer.	ms	-
<i>Runtime last cycle</i>	The duration of each cycle is measured in the control and results from the sum of all set process times (filling duration, waiting intermediate setting, etc.) and all other process values (activation duration of the drives, delays, etc.). If this measures value exceeds the "max. allowed runtime", the error "runtime exceeded" will appear.	ms	-

The screenshot shows the 'Other value' configuration screen. It features the EBRO ARMATUREN logo in the top left. The screen contains four input fields with their respective values and units: 'Delay fault indication' is set to 10000 ms, 'Mutual locking' is set to 400 ms, 'Max. allowed runtime' is set to 20000 ms, and 'Runtime last cycle' is currently empty. At the bottom of the screen, there are two buttons: 'Backward' and 'Info'.



**H08 Operator screen**

Explanation:

Parameter	Description	Unit	Default
<i>Autom. disconnect operator after</i>	Once the set time has been reached, the user will be logged off automatically. "Set up" can first be selected after logging in again.	0 ... ? ms	600,000 ms
<i>New password</i>	The current password is displayed in this field and cannot be changed.	text	ebro





**H09 Maintenance management screen**

Explanation:

Parameter	Description	Unit	Default
<i>Maximum cycles of the valves</i>	Due to wear to the sleeves, the maximum switch cycles of the fixtures are limited. This value is strongly dependent on the process (medium, pressure, etc.) and should be observed by the manufacturer as a recommendation.	number	Dependent on the fixture type
<i>Maximum delay time deviation</i>	The activation times (opening and closing times) are monitored from the switching of the signal output up to reaching the final position. Since two fixtures are available as a reference for each other, differences are evaluated in the activation times and a notification is emitted if the set "maximum delay time deviation" is exceeded.	0 ... 100,000 ms	2,000 ms

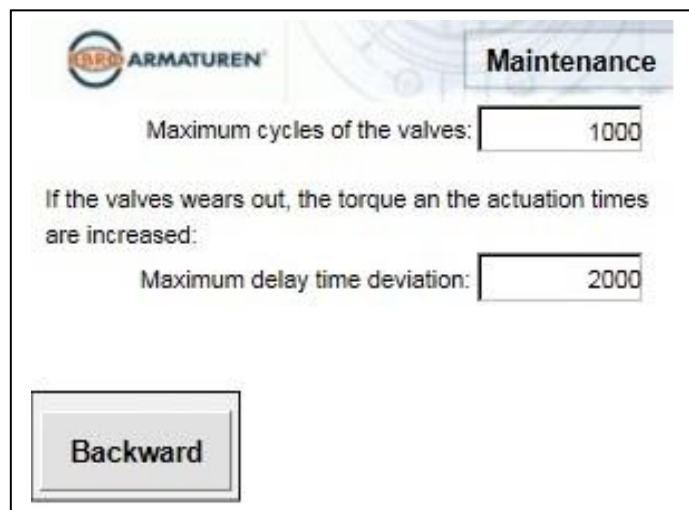

### H10 Clock counter screen

Explanation:

The clock counters are remanent and cannot be influenced by the user. The overview serves for the inspection of the operating history from the cycle lock.

Parameter	Description	Unit	Default
<i>Number of cycles</i>	Clock counter from completely executed lock runs	number	-
<i>Input-valve</i>	Clock counter from the inlet valve		
<i>Output-valve</i>	Clock counter from the outlet valve		

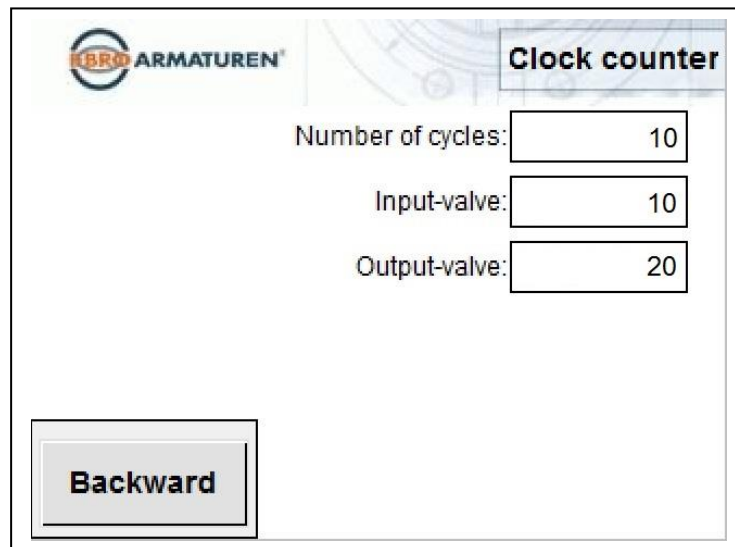

## I) Programming SPS

### I01 *Program organization*

There are two operating modes - automatic and manual.

A single sequence or permanent run can be selected in the automatic mode.

The program is organized as follows:

Templates	Description
Main	In Main, the operating mode selection and the error and notification handling are located.
Lock cycle	Main template for automatic mode. The individual steps worked through sequentially here.
Inputs_outputs	Assignment of the inputs and outputs as well as locking of the signals among each other. With a possible connection to a superior control unit, these commands (binary inputs or signals through a field bus) are executed in a self-retaining manner. The command signals from the visualization are also designed in a self-retaining manner.
Manual	All actions that are possible in the manual operation are organized here. This includes the execution of individual sequences (complete cycle), filling, emptying and the separate, time-independent controlling of all drives.
Organization	General program parts like time, creation of the sequence signal and user log in
Sequence counter	The lock cycles and any activation of the fixtures are counted here.
Runtime	The activation times are dependent on different factors of influence. The runtime from the last sequence cycle is measured in order to compare the runtime monitoring with the process data after every cycle. Additionally, the activation times from the drives (signal output until the final position is reached) are measured, which are also included in the runtime monitoring. A maximum runtime deviation can be set. This cannot be mixed up with the runtime monitoring. During the runtime monitoring for the max. permissible cycle time up to the output of an error, for example, in the event of a blockade, the runtime deviation measures the difference of the activation times from the input and output fixture in order to determine wear and stiffness early enough.
Fixture control	Function template for controlling and monitoring the drives.

**102 Software technical locking**

Independent of the operating mode and the external signal states, all fixtures are locked with each other through locking components. Plus there is a dead time that delays the opening of a fixture after it has been successfully closed.

**103 Access protection**

The automatic mode is freely accessible. The automatic operating mode must be disabled and a password correctly entered to select "Set up".

**104 Safety setting**

There is an emergency off command input. This signal is used internally to immediately stop all processes and shutting down of all outputs.

**105 External control**

External overview of control functions (binary inputs or different field buses).

Identification	Explanation
Automatic	<i>The cycle lock can only be operated by external commands in automatic mode. If the cycle lock is not in the automatic mode, it is in the manual operating status.</i>
Individual sequence	<i>With an increasing flank in the automatic mode, an individual sequence is executed. After this the cycle lock is back in the basic setting.</i>
Permanent run	<i>With an increasing flank in the automatic mode, a permanent run is executed. Initially, it is first emptied, then the lock process is executed in a cyclical manner until another signal flank ends the permanent run. The current cycle is executed until the end.</i>
Safety position (emergency off)	<i>Is handled internally like an emergency off signal. If the signal comes, the automatic mode is ended immediately, all outputs are turned off.</i>

## J) Setting and adjusting

### J01 *General settings*

The cycle lock must be set up for the media to be processed for operation.

However, maintenance and upkeep work may lead to the settings having to be reset.

Before beginning the setting work, read the *Safety* chapter.

The listed safety notes must be followed and are valid for all sub-chapters. Moreover, observe the operating instructions for the purchased parts.

You should empty the complete cycle lock for setting and maintenance work and remove all media from the connected tubing system.

The setting or adjusting must be approved by the operator and may only be executed by qualified staff.

**HAZARD**      **Risk of death through electrical voltage.**



Severe injuries or death through electric shock.

The connecting of the cycle lock may only be executed by an electrician.

Establish a freedom of voltage and secure the cycle lock against being turned on again.

**HAZARD**      **Hazard through uncontrolled starting pneumatic components.**



Severe injuries with incorrectly connected pneumatic components or for pneumatic components that start without being controlled.

The pneumatic components may only be connected by a specialist.

All components and connections must be examined before turning on the pneumatic system.

**CAUTION**      **Hazard through operating or hazardous substances or through media.**



Severe injuries or damage to the cycle lock.

The safety specifications from the operating and hazardous substances must be present and observed.

Use the personal protection equipment required in the safety specifications when handling the respective hazardous substance.

**CAUTION**      **Damage and disruptions on the cycle lock due to incorrect settings.**



Property damage to the cycle lock and, if applicable, low lifespan.

Execute setting work on the cycle lock properly!

Check settings



---

**NOTE**



Release cycle lock and secure against turning on again with a lock.

Release electrical components and cycle locks during all work, before maintenance, setting and upkeep and secure against turning back on.

Release the pressure for all work on pneumatic components and cycle locks and secure against pressure.

---

**HAZARD**



**Life hazard through the non-compliance with the guidelines in the explosive area.**

Severe injuries or death through explosion or fire.

During the assembly and operation of the cycle lock, it must be made sure that the applicable guidelines, directives, etc. are complied with and observed so that sources of ignition are not created due to electrostatic charges!

Observe the guidelines and directives on the operator side!

---



## **K) Maintenance and upkeep**

### ***K01 General maintenance and upkeep***

Before beginning all maintenance and upkeep work, read through the *Safety* chapter. When purchasing spare parts and wear parts, original parts from the EBRO ARMATUREN GmbH and the purchase parts from the manufacturer must be used. It is pointed out that spare parts not delivered from the corresponding manufacturer are not inspected and approved. The installation or usage of such parts may under circumstances cause negative constructional changes to the defined properties of the cycle lock and thereby impair the active or passive operating safety.

For damages that are created through the usage of non-original parts and accessories, the manufacturer has no liability.

Before beginning every shift, the cycle lock must be subject to a short inspection in order to recognize possible damages early on and be able to take required measures for disruption free production processes.

The work and activities on the cycle lock may only be executed by qualified staff, please also observe the *Qualified Staff* chapter for this.

The listed safety notes must be followed and are valid for all sub-chapters. Also observe the operating manual from the connected processing machine, the tubing system and that of the programming.

You should empty the complete cycle lock for setting and maintenance work and remove all media from the connected tubing system.

The maintenance must be approved by the operator and may only be executed by qualified staff.

**CAUTION**      **Damage and disruptions on the cycle lock due to incorrect maintenance.**



Property damage to the cycle lock and, if applicable, low lifespan.

Maintain and repair the cycle lock according to the defined interval!  
Observe shift operation!

**HAZARD**      **Risk of death through electrical voltage.**



Severe injuries or death through electric shock.

The connecting of the cycle lock may only be executed by an electrician.

Establish a freedom of voltage and secure the cycle lock against being turned on again.

**HAZARD**      **Hazard through uncontrolled starting pneumatic components.**



Severe injuries with incorrectly connected pneumatic components or for pneumatic components that start without being controlled.

The pneumatic components may only be connected by a specialist.

All components and connections must be examined before turning on the pneumatic system.



**CAUTION**

**Hazard through operating or hazardous substances or through media.**



Severe injuries or damage to the cycle lock.

The safety specifications from the operating and hazardous substances must be present and observed.

Use the personal protection equipment required in the safety specifications when handling the respective hazardous substance.

**NOTE**



Release cycle lock and secure against turning on again with a lock.

Release electrical components and cycle locks for all work, before maintenance, during adjustment and maintenance and secure against turning on again.

Release the pressure for all work on pneumatic components and cycle locks and secure against pressure.

**HAZARD**



**Life hazard through the non-compliance with the guidelines in the explosive area.**

Severe injuries or death through explosion or fire.

During the assembly and operation of the cycle lock, it must be made sure that the applicable guidelines, directives, etc. are complied with and observed so that sources of ignition are not created due to electrostatic charges!

Observe the guidelines and directives on the operator side!

See chapter A10 for maintenance!



**K02 Maintenance intervals**

Element	Maintenance activity	Maintenance intervals			Information
		Before every shift	Daily	Semi-annually	
Total cycle lock		•			Changes in the operating behavior, in particular those that impair the safety, must be reported immediately and repaired!
Seal from the cycle lock and the flange connections			•		Daily, external visual inspection must be executed Immediately report and repair leaks! Intervals for internal leak check and/or replacement of seal elements in accordance with the operating manual from the fixture types being used.
Total cycle lock	Cleaning			•	All contaminations must be removed at least every 6 months!
Drives	Control			•	All drives must be subject to a visual inspection at least every 6 months!
Fixtures	Control			•	All drives must be subject to a visual inspection at least every 6 months!



### ***K03 Cleaning of the cycle lock before installation***

All internal areas of the fixtures must be free of contamination, in particular there may not be any hard or sharp particles here. This also applies to the tube sections to be connected on the construction side. The tube sections and the flanges must be clean and not have any damages.

In particular, remember that the cover in the casing from the fixture may not come into contact with lubricants, cleaning materials or other substances that do not have proven suitability or are approved by the EBRO ARMATUREN GmbH.

Unsuitable cleaning agents or substances may lead to contamination, swelling or damage to the fixture.

---

#### **CAUTION Leaking through contamination.**



Contamination in fixtures, flanges and construction-side tube sections must be removed.

Contamination that is not removed may lead to damage to the seal surfaces, this in turn leads to leaking.

Make sure that the contamination is removed in a proper manner!

---

### ***K04 General cleaning of the cycle lock***

When operating the cycle lock, a mixture of oil, dust and other foreign objects is occasionally created. The operation and functionality of the cycle lock may be disrupted by these deposits.

In order to avoid these disruptions, you must comply with the maintenance intervals and the cycle lock must be cleaned externally at least every 6 months.

---

#### **HAZARD Hazard through uncontrollably moving components.**



Severe injuries or death when working on running cycle locks.

Before all cleaning work, the cycle lock must be released of all pressure and secured against being turned on again unexpectedly.

Do not execute cleaning work during running operation.

---

#### **CAUTION Hazard through incorrect or aggressive cleaning agent.**



Injuries or damages to the cycle lock.

The safety specifications for the cleaning agent must be present and observed.

Only use a dry cloth and, if applicable, conventional cleaners.

---

Any layers of dust on the components from the cycle lock may decrease the heat exchange of the cycle lock with the surrounding air. This may lead to a heat backup. In order to avoid impermissible temperature increase above the maximum surface temperature, deposits or layers of dust must be removed if present.

Dust deposits must be vacuumed away before the layer thickness reaches 5mm.

**HAZARD**



**Life hazard through increased surface temperature in the explosive area.**

Severe injuries or death through explosion or fire.

When operating the cycle lock, it must be made sure that the media or dust deposits do not lead to an increase in the surface temperature. Observe the technical data for this.

Remove dust deposits from the cycle lock!

**K05 Maintenance of the drives**

The drives are free of maintenance, because the cylinders are equipped with lifespan lubrication. Nevertheless, the drives should be subject to a visual inspection semi-annually and, if applicable, cleaned with a towel.

Pay attention to the maintenance specifications from the construction side compressed air supply. The compressed air used must be filtered with a filter with a 40 µm mesh size in order to protect the magnet valve. The compressed air must be dried and should be slightly greased with switch cycles of  $\geq 4$  x/min.

In order to avoid these disruptions, you must comply with the maintenance intervals and the drives must be cleaned externally at least every 6 months.

**HAZARD**



**Deathly hazard through components or high temperatures from the compressed air in the explosive area.**

Severe injuries or death through explosion or fire.

When operating the cycle lock, it must be made sure that the compressed air does not represent an explosion hazard, whether it is through components or high temperatures in the compressed air.

**K06 Maintenance of the fixture**

The fixtures themselves are maintenance free. Nevertheless, the fixtures should be subject to a visual inspection semi-annually and, if applicable, cleaned with a towel.

During the visual inspection, please also pay attention to the flange connections and screws for the construction side tubing system. If applicable, leaks may be created here, which must be immediately reported and repaired.

In order to avoid these disruptions, you must comply with the maintenance intervals and the fixture must be cleaned externally at least every 6 months.

Furthermore, the flange connections should be inspected manually at least once a year and tightened with a torque wrench. Observe the specified torque of the screws.



## L) Disruptions, causes and repair

### L01 *General disruptions*

Before beginning the troubleshooting, read the chapter *Safety Notes*. The listed safety notes must be followed and are valid for all sub-chapters. Also observe the information from the connected processing cycle lock, the tubing system and that of the programming.

---

**HAZARD**

**Risk of death through electrical voltage.**



Severe injuries or death through electric shock.

The connecting of the cycle lock may only be executed by an electrician.

Establish a freedom of voltage and secure the cycle lock against being turned on again.

---

**HAZARD**

**Hazard through uncontrolled starting pneumatic components.**



Severe injuries with incorrectly connected pneumatic components or for pneumatic components that start without being controlled.

The pneumatic components may only be connected by a specialist.

All components and connections must be examined before turning on the pneumatic system.

---

**CAUTION**

**Hazard through operating or hazardous substances or through media.**



Severe injuries or damage to the cycle lock.

The safety specifications from the operating and hazardous substances must be present and observed.

Use the personal protection equipment required in the safety specifications when handling the respective hazardous substance.

---

**NOTE**



Release cycle lock and secure against turning on again with a lock.

Release electrical components and cycle locks for all work, before maintenance, during adjustment and maintenance and secure against turning on again.

Release the pressure for all work on pneumatic components and cycle locks and secure against pressure.

---

**HAZARD**



**Life hazard through the non-compliance with the guidelines in the explosive area.**

Severe injuries or death through explosion or fire.

During the assembly and operation of the cycle lock, it must be made sure that the applicable guidelines, directives, etc. are complied with and observed so that sources of ignition are not created due to electrostatic charges!

Observe the guidelines and directives on the operator side!

**L02 Error display screen**

Errors are signaled through a blinking of the current status in red. By selecting the "notifications" field, you can end up in the overview of the error notifications.

All error notifications result in the current program being stopped and a moving to the safety positions. Once the cause of the error has been repaired, the cycle lock can be reset through the "ACK" button.

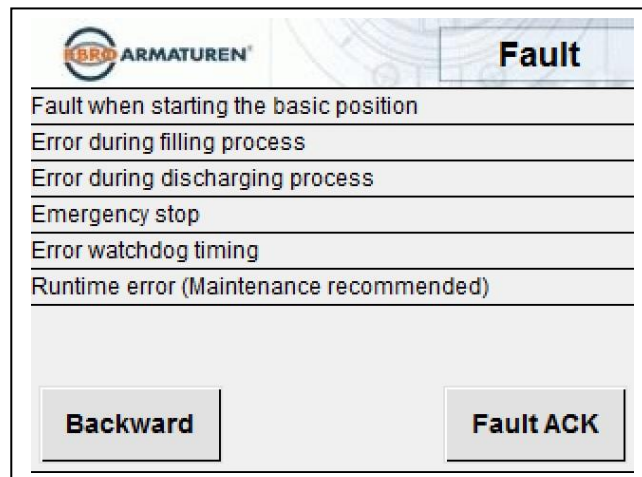



### L03 Errors – Cause – Repair

Disruptions that affect the safety relevant part must be repaired by the manufacturer. These may include:

Error	Cause	Repair
<i>Safety relay reports "error", possible causes:</i>		
	Safety relay reports "error", possible causes	Restart system, check cabling and switching
	Emergency off error	External switching of emergency off - check clamps
<i>Miscellaneous errors, for example, no response from the fixtures</i>		
	Voltage reset Examination of external signals	Inform manufacturer

General errors that occur in the optional control and do not affect the safety relevant part:

Error	Cause	Repair
<i>Leak on the flange connection to the tubing</i>		
	In the area of the flange connections due to an incorrectly mounted connecting screw or due to damages to the seal areas, media escapes between the fixtures of the cycle lock and the tubing system.	Seal flange connection between casing and tubing. Observe the instructions in the operating manual for the tubing and installation note for the corresponding fixture. If the leak cannot be repaired by tightening the flange, it must be guaranteed that the tubing flanges are aligned and parallel to each other. And/or replace the cover from the casing.
<i>Leak on the shaft seal</i>		
	Leaking of the shaft seal.	If the shaft seal is leaking, a repair is necessary. Inform manufacturer





<i>Leak in the passage seal (disc / sleeve sealing)</i>		
	Leaking in the passage seal.	Check if the fixture is 100% closed with complete actuating torque. If the fixture is still leaking in a closed position, open and close the fixture multiple times under pressure. If the fixture is still leaking, a repair is necessary. The casing covering (sleeve) must be replaced. Inform manufacturer
<i>A drive from the cycle lock does not work</i>		
	The voltage supply to the magnetic valve is disrupted.	Inform manufacturer
	No supply of the drive with a control medium. Supply is disrupted.	Restore supply with control medium.
	Control pressure on the drive is too low.	Set control pressure.
	Magnetic valve is defective.	Inform manufacturer
	Drive is completely defective and no longer works correctly.	Inform manufacturer
<i>Drive can no longer be moved to the final position</i>		
	Settings on the drive no longer fit or were changed.	Reset or renew drive.
<i>Fixture can no longer be moved to the final position</i>		
	Settings on the drive no longer fit or were changed.	Reset or renew drive. Inform manufacturer
<i>Emergency off</i>		
	An external emergency off command is signaled.	Check emergency off button. Once the operating state has been renewed, the control can be reset through the "ACK" button.
<i>Disruption while starting the basic setting</i>		
	The fixture settings are examined at the beginning of every new lock cycle. If a fixture is not in the closed position, the cycle lock will try to close this. If the final position notification is not active within the time frame of the error message (parameter "delay error message"), the cycle will be canceled, the error message emitted, automatic mode	Examination of the fixture settings, function of the end switch, signal wire and the SPS inputs. In manual mode, the fixtures may be opened and closed for testing purposes.



<i>Error during filling process</i>		
	In automatic mode, an error occurred while filling the cycle lock. The final position switches are not in the correct logical order, depending on the defined time frames (parameter "fill permanently" and "delay error message")	Examination of the fixture settings, function of the end switch, signal wire and the SPS inputs. In manual mode, the fixtures may be opened and closed for testing purposes.
<i>Error during emptying process</i>		
	In automatic mode, an error occurred while emptying the cycle lock. The final position switches are not in the correct logical order, depending on the defined time frames (parameter "empty permanently" and "delay error message")	Examination of the fixture settings, function of the end switch, signal wire and the SPS inputs. In manual mode, the fixtures may be opened and closed for testing purposes.
<i>Error watchdog timing</i>		
	Through the "max. permissible runtime" parameter, an upper limit can be set for the duration of the individual lock cycles. This is normally defined through the entire process of the cycle lock. The duration is measured in the control and results from the sum of all set process times (filling duration, waiting intermediate setting, etc.) and all other process values (activation duration of the drives, delays, etc.). If this measures value exceeds the "max. permissible runtime", the error "runtime exceeded" will appear.	If this message appears with a change to the process parameters, there is most likely stiffness in the fixtures or an error in the sensors (end switch, wire, SPS). The error can be reset by acknowledging it. If the cause is not repaired, the cycle lock will report this error message again during the next cycle.
<i>Runtime error (maintenance recommended)</i>		
	Message - no error The activation times (opening and closing times) are monitored from the switching of the signal output up to reaching the final position. Since two fixtures are available as a reference for each other, differences are evaluated in the activation times and a notification is emitted if the set "maximum delay time deviation" is exceeded.	The fixture sleeve could be worn.



## M) Disposal

### M01 Environment protection

Contribute to environment protection by recycling valuable raw materials and thereby protecting resources.

We also point out the respective disposal guidelines for the countries.

What must be disposed of?	Material	How should it be disposed?
Transportation material Packaging	Pallets Paper and cartons Plastics	Return to the manufacturer or courier For recyclable paper Plastic recycling
Cleaning rags Oil and grease	Fabric, oil and grease	Oil and waste containing grease
Components	Control Electronic devices and components Metal Plastics	Add to electronic garbage Add to electronic garbage Metal recycling Add to plastic recycling

**CAUTION Hazard through operating or hazardous substances.**



Severe injuries or severe environmental damage.

The safety specifications from the operating and hazardous substances must be present and observed.

Use the personal protection equipment required in the safety specifications when handling the respective hazardous substance.

For all work on and with the cycle lock, the legal obligations to avoid waste and for the proper usage and disposal must be complied with according to the safety specifications!

In particular during installation, repair and maintenance work, substances that pose water hazards, like lubricants and oils, may not be exposed to the ground or end up in the sewage system! These substances must be stored, transported, collected and disposed of in suitable containers!



## **N) Spare parts**

### ***N01 General spare parts***

When purchasing spare parts and wear parts, original parts from the EBRO ARMATUREN GmbH and the purchase parts from the manufacturer must be used. It is pointed out that spare parts not delivered from the corresponding manufacturer are not inspected and approved. The installation or usage of such parts may under circumstances cause negative constructional changes to the defined properties of the cycle lock and thereby impair the active or passive operating safety.

For damages that are created through the usage of non-original parts and accessories, the manufacturer has no liability.

### ***N02 Spare parts order***

The following information must be provided for every spare parts order:

- Type.
- Order number.
- Part no. (parts catalog).
- Identification no. or drawing no. (parts catalog).

If these 4 parts are not complied with, a quick processing of the ordered spare part cannot be guaranteed.



## O) Technical data

For further technical data, please refer to the documentation of the individual components of the cycle lock.



## P) Index

Accident prevention guidelines	20	Media temperature	35
Additions	17	Medium	10
Assembly	39	Mobile drives	62
Assembly work	22	Note symbols	9
Burning hazard	26	Operating personnel	10
Cleaning agents	22	Operating voltage	24
Cold burns	27	Operation	68
Compressed air components	23	Operator	12
Compressed air wire	50	Original fuses	24
Control diagram	52	Pipe system	11
Control medium	50	Products	10
Control unit	62	Protective rights	12
Counter-flange	40	Proximity switch	66
Crane	37	Qualified staff	14
Current strength	24	Restructuring	17
Cycle lock	10	Ring loops	38
Degree of protection	35	Safety specifications	25
Disassembly	54	Scope of delivery	62
Environment temperature	35	Screw connections	21
Factory equipment	21	Screws	21
Fall safety mechanisms	22	Setting work	81
Filling tube	62	Spare parts	83, 95
Fixtures	62	Standing spaces	22
Flange	40	Step	64
Folding panel	40	Storage	36
Forklift	37	Switch cabinet	24
Frequency	24	System	10
Functional disruptions	21	Temperatures	35
Hazard symbols	8	Tightening torque	21
Identification	16	Transportation	36
Liability	12	Troubleshooting	88
Lifting equipment	37	Tube adapter	43
Locking	66	Usage area	35
Machine	10	Voltage	24
Maintenance	83	Weight	36
Media	10	Workplaces	39