

# Operating and installation instructions

## Stop valve with gland seal

### STOBU® PN16-40

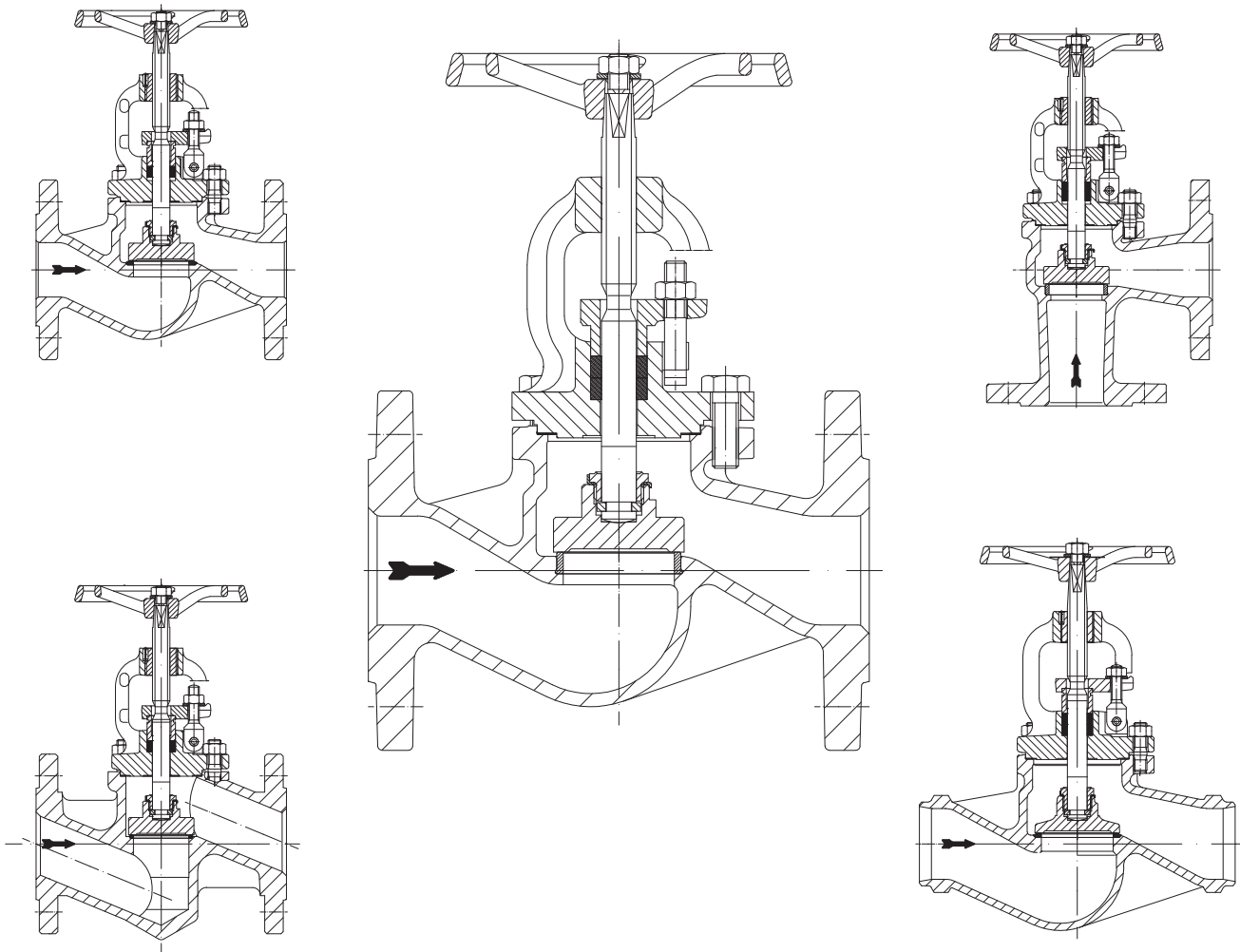

### Contents

<b>1.0 General information on operating instructions</b> .....	<b>2-2</b>	5.4 Installing valves with limit switches .....	2-8
<b>2.0 Notes on possible dangers</b> .....	<b>2-2</b>	<b>6.0 Putting the valve into operation</b> .....	<b>2-8</b>
2.1 Significance of symbols .....	2-2	<b>7.0 Care and maintenance</b> .....	<b>2-9</b>
2.2 Explanatory notes on safety information .....	2-2	<b>8.0 Troubleshooting</b> .....	<b>2-10</b>
<b>3.0 Storage and transport</b> .....	<b>2-2</b>	<b>9.0 Troubleshooting table</b> .....	<b>2-11</b>
<b>4.0 Description</b> .....	<b>2-3</b>	<b>10.0 Dismantling the valve or the top part</b> ..	<b>2-12</b>
4.1 Scope of applications .....	2-3	<b>11.0 Warranty / Guarantee</b> .....	<b>2-12</b>
4.2 Operating principles .....	2-3		
4.3 Diagram .....	2-4		
4.4 Technical data - remarks .....	2-5		
4.5 Marking .....	2-5		
<b>5.0 Installation</b> .....	<b>2-5</b>		
5.1 General notes on installation .....	2-5		
5.2 Installing valves with butt weld ends .....	2-6		
5.3 Installing valves with balancing plugs .....	2-7		

## 1.0 General information on operating instructions

These operating instructions provide information on mounting and maintaining the fittings. Please contact the supplier or the manufacturer in case of problems which cannot be solved by reference to the operating instructions.

They are binding on the transport, storage, installation, start-up, operation, maintenance and repair.

The notes and warnings must be observed and adhered to.

- Handling and all work must be carried out by expert personnel or all activities must be supervised and checked.

It is the owner's responsibility to define areas of responsibility and competence and to monitor the personnel.

- In addition, current regional safety requirements must be applied and observed when taking the fittings out of service as well as when maintaining and repairing them.

The manufacturer reserves the right to introduce technical modifications at any time.

These Operating Instructions comply with the requirements of EU Directives.

## 2.0 Notes on possible dangers

### 2.1 Significance of symbols



Warning of general danger.

### 2.2 Explanatory notes on safety information

In these Operating and Installation Instructions dangers, risks and items of safety information are highlighted to attract special attention.

Information marked with the above symbol and "**ATTENTION!**" describe practices, a failure to comply with which can result in serious injury or danger of death for users or third parties or in material damage to the system or the environment. It is vital to comply with these practices and to monitor compliance.

All other information not specifically emphasised such as transport, installation, operating and maintenance instructions as well as technical data (in the operating instructions, product documentation and on the device itself) must also be complied with to the fullest extent in order to avoid faults which in turn can cause serious injury to persons or damage to property.

## 3.0 Storage and transport

	<p><b>ATTENTION !</b></p> <ul style="list-style-type: none"><li>- <i>Protect against external force (like impact, vibration, etc.).</i></li><li>- <i>Valve mountings such as actuators, handwheels, hoods must not be used to take external forces, e.g. they are not designed for use as climbing aids, or as connecting points for lifting gear.</i></li><li>- <i>Suitable materials handling and lifting equipment should be used.</i></li></ul> <p><i>See catalog sheet for weights.</i></p>
---	--

- At -20°C to +65°C.

- The paint is a base coat to protect against corrosion during transportation and storage. Do not damage paint protection.

## 4.0 Description

### 4.1 Scope of applications

Valves are used for „shut-off and/or throttling of media“.



#### **ATTENTION !**

- Refer to the data sheet for applications, limits on use and possibilities.
- Certain media require or preclude the use of special materials.
- The valves are designed for standard operating conditions. If conditions exceed these requirements, e.g. aggressive or abrasive media, the operator should state the higher requirements when ordering.
- Valves made from grey cast iron are not authorised for use in systems subject to TRD 110.

The information complies to the Pressure Equipment Directive 97/23/EC.

It is the responsibility of the machine planner to ensure compliance.

The special markings on the valve must be taken into account.

Refer to the catalogue sheet to see which materials are used in standard versions.

Please contact the supplier or the manufacturer if you have any questions.

### 4.2 Operating principles

The valve is closed by turning the hand wheel clockwise (valve plug/seating function).



#### **ATTENTION !**

*Do not use tools to increase the torque on the hand wheel.*

The valve spindle is sealed by a bellow and an outer safety stuffing box.

Tighten the stuffing box if required.

### 4.3 Diagram

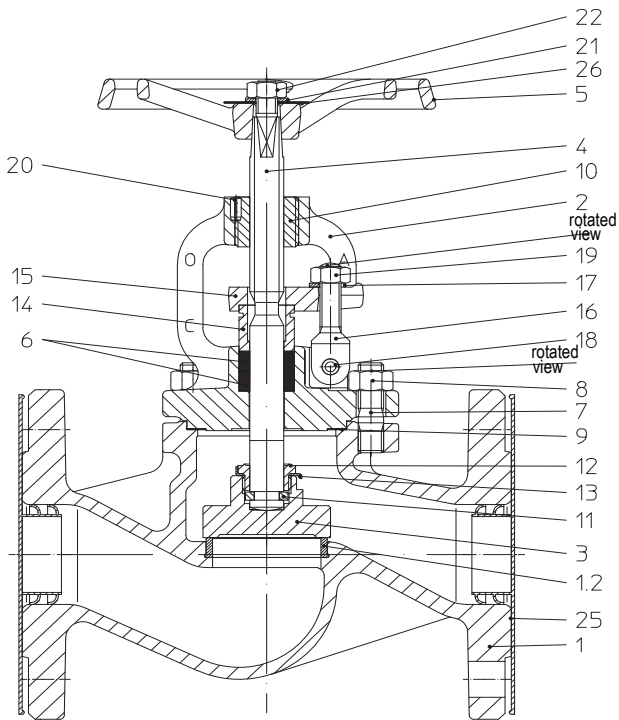

fig. 1: STOBU straight through 1.0619+N

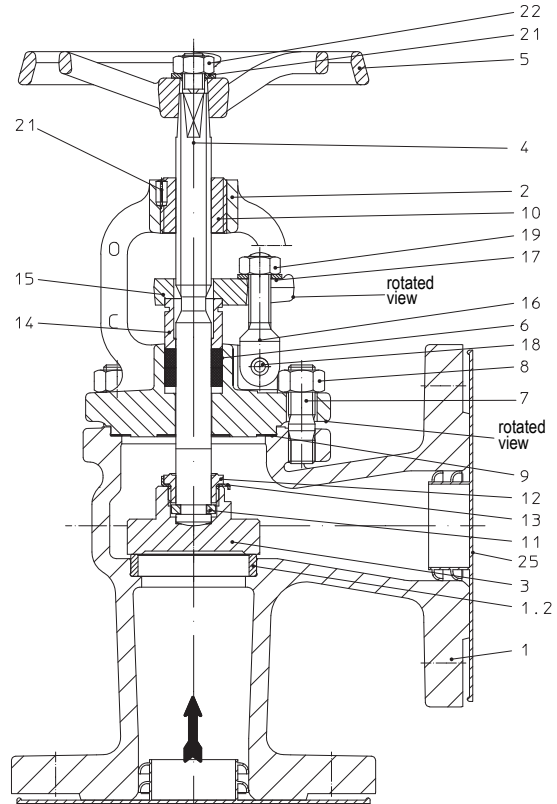

fig. 2: STOBU angle pattern 1.0619+N

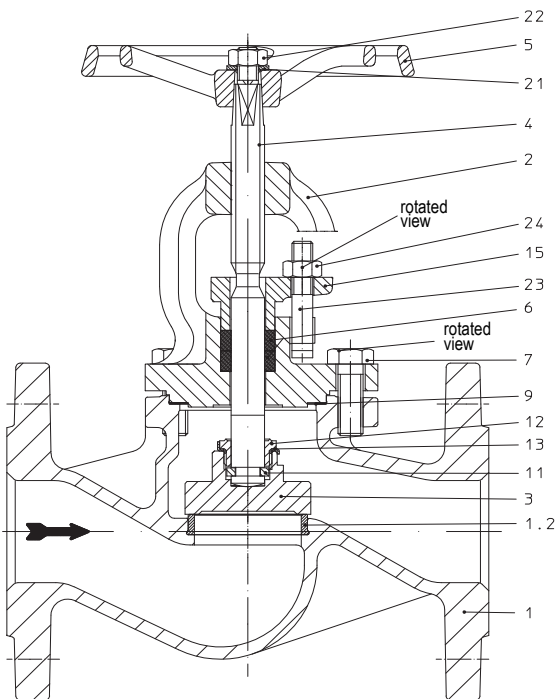

fig. 3: STOBU straight through  
 EN-JL1040/JS1049

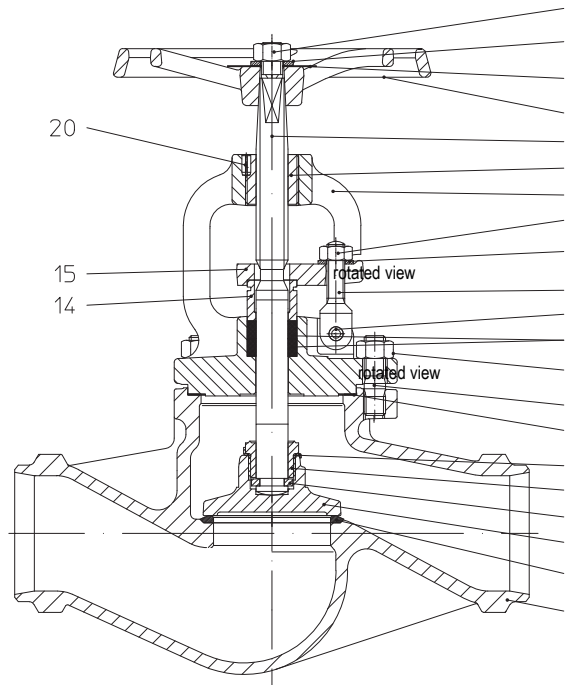

fig. 4: STOBU-straight through  
 butt weld ends 1.0619+N

Refer to the data sheet for information about materials with designations and figure numbers.

## 4.4 Technical data - remarks

for

- Principal dimensions
- Pressure-temperature-ratings
- Valves with butt weld ends, etc. refer to datasheet.

## 4.5 Marking

Details of the CE-marking on the valve:

 CE-marking

0525 Notified body



Manufacturer

Address of manufacturer:

Typ Type

refer to item 11.0 Warranty / Guarantee

Bj. Year of manufacture

According to the Pressure Equipment Directive table 6, annex II, valves without safety function are only allowed to bear the CE-marking DN32 onwards.

## 5.0 Installation

### 5.1 General notes on installation

The following points should be taken into account besides the general principles governing installation work:



#### **ATTENTION !**

- Remove flange covers if present.
- The interior of valve and pipeline must be free from foreign particles.
- Note installation position with reference to flow, see mark on valve.
- Steam line systems should be designed to prevent water accumulation.
- Lay pipelines so that damaging transverse, bending and torsional forces are avoided.
- Protect valves from dirt during construction work.
- Connection flanges must mate exactly.
- Connecting bolts for pipe flanges should be mounted preferably from the counter flange side (hexagon nuts from the valve side).  
At DN15-32: If valves should be mounted directly to valves, the upper flange connecting bolts should be preferably executed with studs and hexagon nuts on both sides.
- Valve mountings such as actuators, handwheels, hoods must not be used to take external forces, e.g. they are not designed for use as climbing aids, or as connecting points for lifting gear.
- Suitable materials handling and lifting equipment should be used.  
See data sheet for weights.

- Valves can be installed with the spindle pointing in any direction, but the preferred spindle position is vertical.
- Valves should be installed upside down only, if the medium being handled is clean.
- Keep the thread and shaft of the spindle free from paint.
- Centre gaskets between the flanges.
- Lockable stop valves must be installed in such a way that the spindle is vertical and the flow agent enters under the taper. If the valves are installed in pipelines in positions other than specified, they must be fitted with a closing spring.
- Design with loose plug  
*A plug damper should be used in critical applications, immediately downstream of pumps, compressors, etc., where severe turbulence and pulsating pressure surges may occur.*  
*Through the damper function of the loose plug, the negative influence of pressure shocks and high turbulences, are not transferred onto the valve.*

- Planners / construction companies or operators are responsible for positioning and installing products.
- The valves are designed for application, not influenced from weather.
- For application outside or in adverse environments like corrosion-promoting conditions (sea water, chemical vapours, etc.), special constructions or protective measures are recommended.

## 5.2 Installing valves with butt weld ends

Please note that only qualified persons using appropriate equipment and working in accordance with technical rules are allowed to install fittings by welding.

The responsibility for this lies with the system owner.

Refer to the data sheet for information about the shape of the butt weld ends.

The valves must be welded in closed position.

### 5.3 Installing valves with balancing plugs



**ATTENTION !**  
ARI stop valves must be equipped with pressure balancing plugs if the differential pressures listed in the table below are exceeded in the closed state.  
Valves with pressure balancing plugs should be installed so that the pressure of the medium acts on the plug (pos. 3) and the stem is vertically upright.

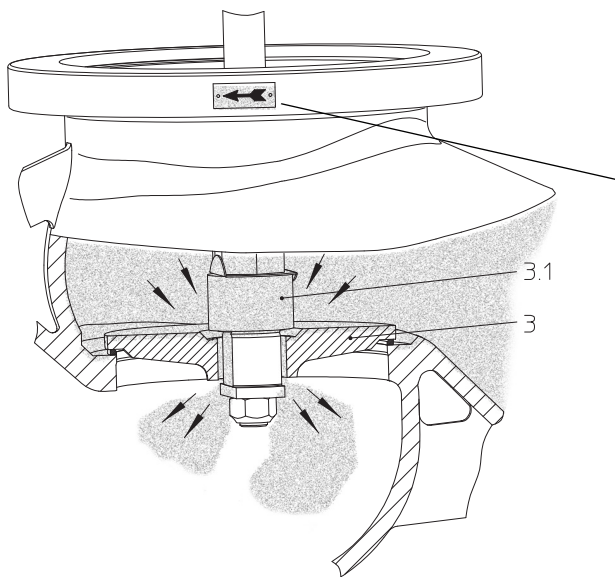



**ATTENTION !**  
Note direction of flow.

fig. 5

Working principles:

When the valve is closed, anticlockwise rotation of the hand wheel lifts the pilot plug (pos. 3.1) off the larger balancing plug (pos. 3). This allows the medium to pass through the plug and equalizes the pressure of the medium under the plug (pos. 3). After the pressures have been equalized within the values stated in the table below, the valve can be opened by turning the valve further.

Balancing plug	DN	125	150	200	250	300	350	400	500
Pressure difference	$\Delta P$	25 bar	21 bar	14 bar	9 bar	6 bar	4,5 bar	3,5 bar	1,5 bar

- Pressure balancing plugs are fully effective only in closed line section.
- The pressures of the medium on either side of the plug cannot be equalized if the medium is discharged into "open air".
- If adequate pressure equalisation cannot be achieved using a pressure balancing plug, other design solutions must be used instead (e.g. a bypass line).

## 5.4 Installing valves with limit switches

The valves with limit switches must be connected up as shown in the plans of the plant on the basis of their working principles.

## 6.0 Putting the valve into operation



### **ATTENTION !**

- *Before putting the valve into operation, check material, pressure, temperature and direction of flow.*
- *Regional safety instructions must be adhered to.*
- *Residues in piping and valves (dirt, weld beads, etc.) inevitably lead to leakage.*
- *Touching the valve when it is operating at high (> 50 °C) or low (< 0 °C) media temperatures can cause injury.*

*Affix warning notice or protective insulation as appropriate.*

*Before putting a new plant into operation or restarting a plant after repairs or modification, always make sure that:*

- *All works has been completed.*
- *The valve is in the correct position for its function.*
- *Safety devices have been attached.*



## 7.0 Care and maintenance

Maintenance and maintenance-intervals have to be defined by the operator according to the requirements.

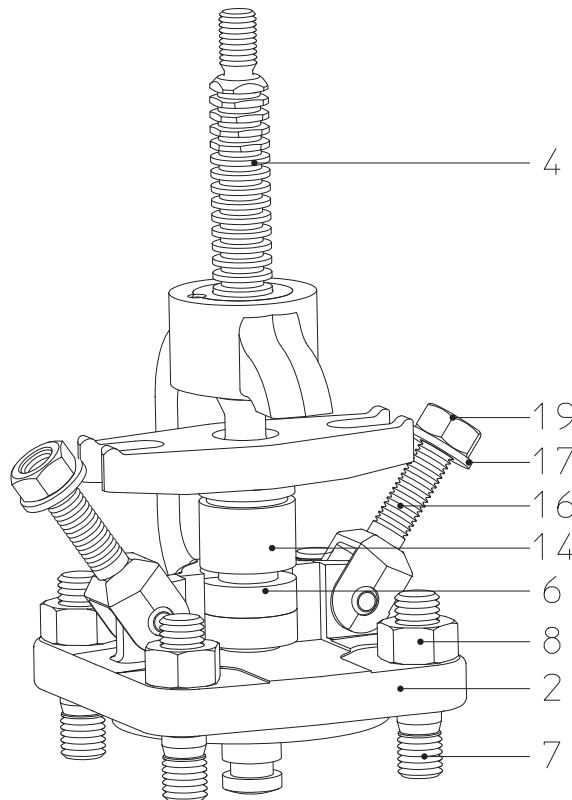

fig. 6: Pattern with hinged bolts

- Observe safety instructions!
- Keep the spindle well greased!
- Lubricant: e.g. Klüberpaste HEL 46-450 (at valves for oxygen: Klüberalfa YV93-302)  
to order at: Klüber Lubrication München KG, Postfach 701047, D-81310 München  
or a lubricant which is suitable for the application.



**ATTENTION !**

*Pay attention, that the lubricant is suitable for the media.*

- If the valve spindle (pos. 4) leaks, gradually tighten the stuffing box seal (pos. 6) evenly in increments by means of the hex. nuts (pos. 19) until leaking stops.



**ATTENTION !**

- *Retighten the stuffing box packing if required and re-pack it in good time.*
- *For safety reasons we recommend that valves only be repacked when depressurised.*
- ***Refer to point 10.0 and 11.0 before dismantling the valve.***

- Replace stuffing box packings only after the system has cooled down and the pressure in the plant has been relieved.  
In the case of corrosive or aggressive mediums, drain and ventilate the valve before replacing the packing.

- Valve service life can be improved by leakage checks.

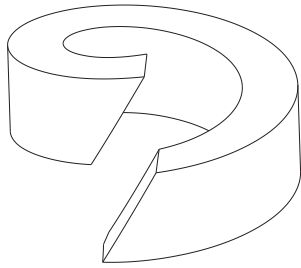

fig. 7: Split packing ring

- When cutting the new packing from the roll, make sure that the ends are cut with a slant (see fig. 7).

Mounting of the bonnet:

- Before reassembling the unit, remember that the bearing surface must be cleaned and a new gasket (pos. 9) must be inserted.
- Set the cover in place
- Tighten the hexagon nuts (hexagon screws for valves of cast iron) evenly crosswise.
- Tightening torque's for hexagon nuts / screws:

DN	hexagon nuts / hexagon screws	Torque (Nm)
15- 32	M 10	15-30
40- 65	M 12	35-50
80-100	M 16	75-100
125-150	M 16	80-120
200	M 20	150-200
250-400	M 24	340-410
500	M 27	340-410

## 8.0 Troubleshooting

In the event of malfunction or faulty operating performance check that the installation and adjustment work has been carried out and completed in accordance with these Operating Instructions.



### **ATTENTION !**

It is essential that the safety regulations are observed when identifying faults.

If malfunctions cannot be eliminated with the help of the following table "9.0 Troubleshooting table", the supplier or manufacturer should be consulted.

## 9.0 Troubleshooting table



**ATTENTION !**  
*- read point 10.0 and 11.0 prior to dismantling and repair work!*  
*- read point 6.0 before restarting the plant !*

Fault	Possible cause	Corrective measures
No flow	Valve closed.	Open valve.
	Flange covers not removed. (pos. 25; fig. 1-2)	Remove flange covers. (pos. 25; fig. 1-2)
Little flow	Valve not sufficiently open.	Open valve.
	Dirt sieve clogged.	Clean / replace sieve.
	Piping system clogged.	Check piping system.
Valve difficult to move or cannot be opened	Spindle dry (pos.4; fig. 6)	Grease spindle (pos. 4) (fig. 6) (Lubricant: see page 9)
	Stuffing box too tight (pos. 6; fig. 1-4)	Slacken hex. nuts of stuffing box gland (pos. 15) slightly, but not sufficiently to cause leakage (fig. 1-4)
	Wrong direction of rotation	Turn in correct direction (anticlockwise to open valve).
Valve spindle leaking	Stuffing box gland (pos. 15) slack (fig. 1-4).	Tighten stuffing box gland (pos. 15) until leakage stops. -Hex. nut (fig. 1-4).
		If necessary, renew packing in stuffing box seal (pos. 6). Observe warnings (fig. 6)!
Leakage across valve seat.	Valve not properly closed.	Pull hand wheel tight without tools.
	Seat (pos. 1.2) / plug (pos. 3) damaged by foreign particles. (fig. 1-4).	Replaced valve, consult supplier/man- ufacturer.
	Pressure difference too high.	Use a valve with balancing plug (see point 5.3).
	Medium contaminated (suspended solids).	Clean valve. Install dirt screen upstream of valve.
Valve with throttling plug + position indicator + locking device cannot be opened.	Locking device has been tightened.	Release locking device.
Rattling / banging of the plug design with „loose plug“	Nominal diameter of the valve in compliance to the flow rate is <u>to big</u>  - high flow turbulences; - the valve with loose plug is mounted directly by a centrifuged pump; - behind pressure reduction stations; - behind pipe elbows; - in compact plants; - expansion joints are missing; - the pump is not mounted on a damper; - there is no flow stabilizing pipe length; - there is no start-up bypass line	Choose smaller nominal diameter
		Use a plug damper execution: see medium
		Alter the system Use a plug damper execution: see medium
Flange broken between valve and piping.	Bolts tightened unevenly. Mating flanges not properly aligned.	Re-align piping and fit new valve!

## 10.0 Dismantling the valve or the top part



### **ATTENTION !**

*The following points must be observed:*

- *Pressureless pipe system.*
- *Medium must be cool.*
- *Plant must be drained.*
- *Purge piping systems in case of caustic, inflammable, aggressive or toxic media.*

## 11.0 Warranty / Guarantee

The extent and period of warranty cover are specified in the "Standard Terms and Conditions of Albert Richter GmbH & Co. KG" valid at the time of delivery or, by way of departure, in the contract of sale itself.

We guarantee freedom of faults in compliance with state-of-the-art technology and the confirmed application.

No warranty claims can be made for any damage caused as the result of incorrect handling or disregard of operating and installation instructions, datasheets and relevant regulations.

This warranty also does not cover any damage which occurs during operation under conditions deviating from those laid down by specifications or other agreements.

Justified complaints will be eliminated by repair carried out by us or by a specialist appointed by us.

No claims will be accepted beyond the scope of this warranty. The right to replacement delivery is excluded.

The warranty shall not cover maintenance work, installation of external parts, design modifications or natural wear.

Any damage incurred during transport should not be reported to us but *rather* to the competent cargo-handling depot, the railway company or carrier company immediately or else claims for replacements from these companies will be invalidated.



**Technology for the Future.**

**GERMAN QUALITY VALVES**

ARI-Armaturen Albert Richter GmbH & Co. KG, D-33756 Schloß Holte-Stukenbrock

Telephone (+49 5207) 994-0 Telefax (+49 5207) 994-158 or 159

Internet: <http://www.ari-armaturen.com> E-mail: [info.vertrieb@ari-armaturen.com](mailto:info.vertrieb@ari-armaturen.com)