

## SERIES BV BT ANSI RANGE

Series BT are trunnion type, featured by the upper and lower ball guidance, quick closing 90° rotary ball valves, bidirectional, with tightness achieved by friction of the ball blind ends to the seats, devised for stopping the flow of the service fluid when necessary and not being suitable for regulation purposes. Valves can be operated by manual gear by handwheel (valve closes by turning the hand lever clockwise) or a choice of quarter turn electric, pneumatic or hydraulic actuators. They have a robust construction to offer reliable performance in standard services.

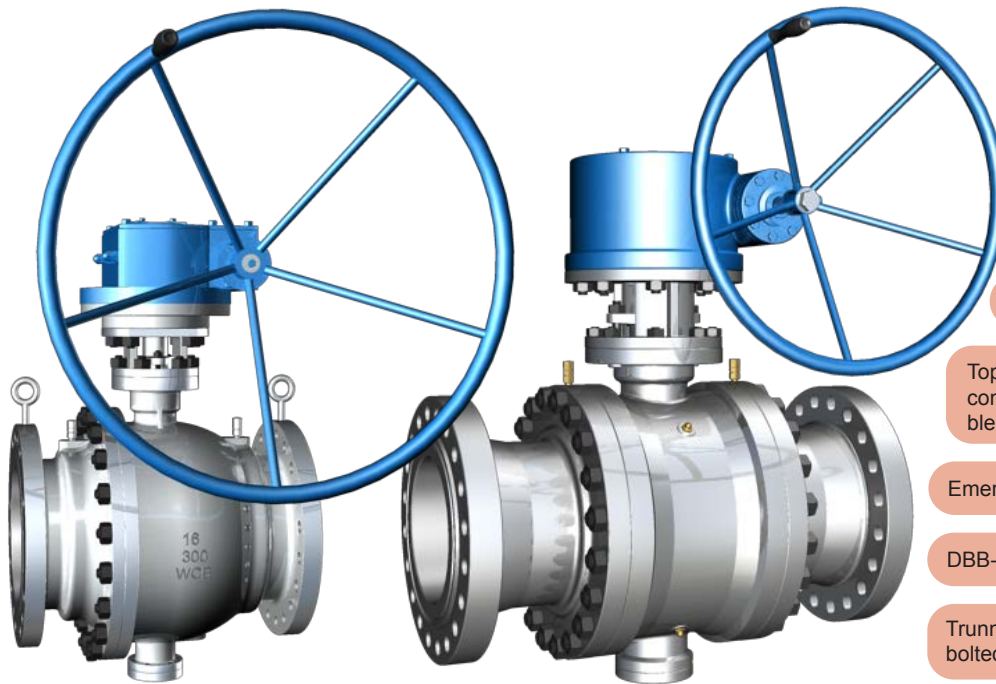

Fire safe design

Anti-static feature

Blow out proof stem

Self-relieving seat

Lifting lugs and supporting feet

Top flange drilled to ISO 5211. A complete range of brackets available for easy and quick automation

Emergency Sealant Injection System

DBB-Double bleed and block function

Trunnion ball, full bore, side entry, split bolted body (two-pieces, three-pieces)

Nameplate incl. batch no. for full traceability

### Main Features / Reference Standards

Design: API 6D  
 Pressure Rating: 150/300/600/900/1500/2500#  
 Face to face length: API 6D  
 Valve end connections: Flanged RF or RTJ to ASME B16.5 (size ≤ 24") / ASME B16.47 (size > 24")  
 Welded BW to ASME B16.25  
 Fire safe design: API 6FA  
 Bidirectional design  
 Marking: MSS SP-25  
 Inspections & Tests: API 598  
 Primer painted grey color similar to RAL 7037 for protection during storage and transport (carbon steel body/bonnet)  
 Product compliant with Directive 2014/68/EU on Pressure Equipment (PED) and Machinery Directive 2006/42/EC for European Union territory

### Main Duties / Limits of use

Fluids compatible with materials of construction. Questions referring to chemical resistance, please consult us  
 Pressure / Temperature Rating to ASME B16.34. See section "Engineering & Performance Data"  
 For products compliant with Directive 2014/68/EU, observe also limits acc. to Annex II tables 6 & 8 (gases & liquids group 1\*) and tables 7 & 9 (gases & liquids group 2\*) up to category III  
 \*Classification of fluids (group 1 or 2) acc. to Directive 2014/68/EU, Article 13

### Options

Different material combinations, different valve connections, worm gear, actuators, limit switches, cryogenic design, 3-Way T or L type, DPE-Double piston effect function, jacketed body, execution for aggressive atmosphere, underground application structure, manufacturing to NACE MR0175, etc. Please consult us

Main Parts and Materials

SERIES BV BT ANSI RANGE  
Class 150&300 NPS2-5"

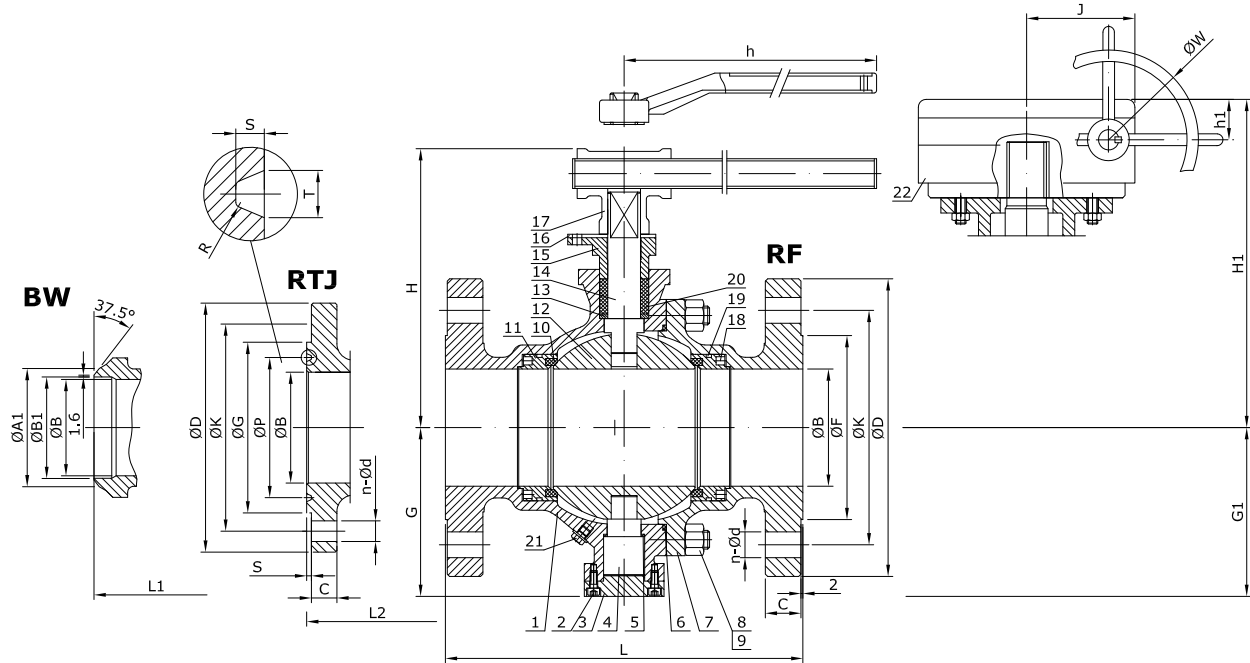

Nº	Part name	A216 WCB (BTA02_)	A216 WCB	A352 LCB	A352 LCB	A351 CF8 (BT12_)	A351 CF8M (BT10_)	A351 CF3 (BT11_)	A351 CF3M (BT17_)
1	Body	A216 WCB		A352 LCB		A351 CF8	A351 CF8M	A351 CF3	A351 CF3M
2	Screw	A193 B7	A193 B7M	A320 L7	A320 L7	A193 B8	A193 B8M	A193 B8M	
3	Bottom Cover	ASTM A105		A350 LF2		A182 F304	A182 F316	A182 F304L	A182 F316L
4	Trunnion	A182 F6a	17-4PH	A182 F304	A182 F316	A182 F304	A182 F316	A182 F304L	A182 F316L
5	Gasket	A276 410	A276 316	A276 304	A276 316	A276 304	A276 316	A276 316	
6	Body Gasket	SS304 + Graphite	SS316 + Graphite	SS304 + Graphite	SS316 + Graphite	SS304 + Graphite	SS316 + Graphite	SS304 + Graphite	SS316 + Graphite
7	Body Cap	A216 WCB		A352 LCB		A351 CF8	A351 CF8M	A351 CF3	A351 CF3M
8	Body Bolt	A193 B7	A193 B7M	A320 L7		A193 B8	A193 B8M	A193 B8M	
9	Body Nut	A194 2H	A194 2HM	A194 4		A194 8	A194 8M	A194 8M	
10	Seat	RPTFE		RPTFE		RPTFE		RPTFE	
11	Seat Retainer	ASTM A105	ASTM A105N	A350 LF2		A182 F304	A182 F316	A182 F304L	A182 F316L
12	Ball	A105.ENP	A105N.ENP	A182 F304	A182 F316	A182 F304	A182 F316	A182 F304L	A182 F316L
13	Packing Gasket	A276 410	A276 316	A276 304	A276 316	A276 304	A276 316	A276 316	
14	Stem	A182 F6a	17-4PH	A182 F304	A182 F316	A182 F304	A182 F316	A182 F304L	A182 F316L
15	Gland Flange	A216 WCB		A352 LCB		A351 CF8		A351 CF3	
16	Positioner Plate	AISI 1035		AISI 1035		St. Steel		St. Steel	
17	Lever	A216 WCB		A216 WCB		A216 WCB+Epoxy Coated	A216 WCB+Epoxy Coated	A216 WCB+Epoxy Coated	A216 WCB+Epoxy Coated
18	Seat Spring	17-7PH		17-7PH		Inconel X-750		Inconel X-750	
19	O Ring	VITON		VITON		VITON		VITON	
20	Packing	Flexible Graphite		Flexible Graphite		PTFE		PTFE	
21	Drain Plug	AISI 1035	A182 F316	A182 F304	A182 F316	A182 F304	A182 F316	A182 F304L	A182 F316L
22	Worm Gear	Assembly		Assembly		Assembly		Assembly	



Main Parts and Materials

SERIES BV BT ANSI RANGE  
Class 150&300 NPS18-36"

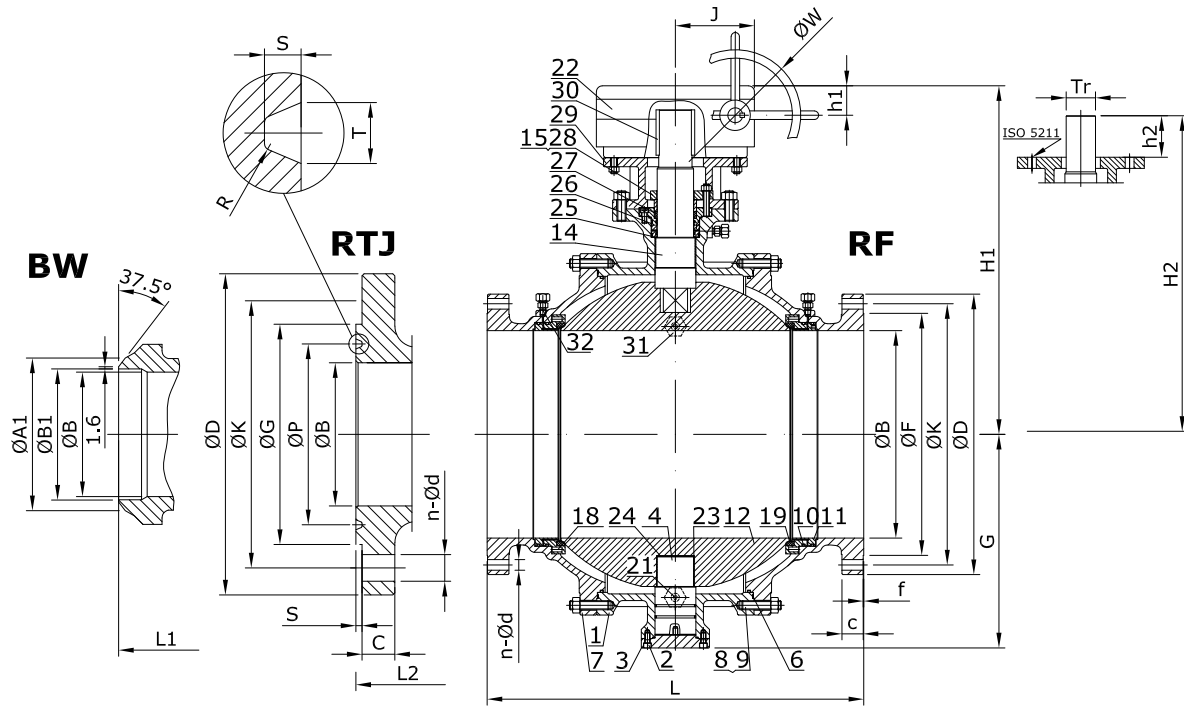

Nº	Part name	A216 WCB (BTA02_)	A216 WCB/ NACE (BTA02_)	A352 LCB/ SS304 (BTA82_)	A352 LCB/ SS316 (BTA83_)	A351 CF8 (BTI2_)	A351 CF8M (BTI0_)	A351 CF3 (BTI1_)	A351 CF3M (BTI7_)
1	Body	A216 WCB		A352 LCB		A351 CF8	A351 CF8M	A351 CF3	A351 CF3M
2	Screw	A193 B7	A193 B7M	A320 L7		A193 B8	A193 B8M	A193 B8M	
3	Bottom Cover	ASTM A105	ASTM A105N	A350 LF2		A182 F304	A182 F316	A182 F304L	A182 F316L
4	Trunnion	A182 F6a	17-4PH	A182 F304	A182 F316	A182 F304	A182 F316	A182 F304L	A182 F316L
6	Body Gasket	SS304 + Graphite	SS316 + Graphite	SS304 + Graphite	SS316 + Graphite	SS304 + Graphite	SS316 + Graphite	SS304 + Graphite	SS316 + Graphite
7	Body Cap	A216 WCB		A352 LCB		A351 CF8	A351 CF8M	A351 CF3	A351 CF3M
8	Body Bolt	A193 B7	A193 B7M	A320 L7		A193 B8	A193 B8M	A193 B8M	
9	Body Nut	A194 2H	A194 2HM	A194 4		A194 8	A194 8M	A194 8M	
10	Seat	RPTFE		RPTFE		RPTFE		RPTFE	
11	Seat Retainer	ASTM A105	ASTM A105N	A350 LF2		A182 F304	A182 F316	A182 F304L	A182 F316L
12	Ball	A105.ENP	A105N.ENP	A182 F304	A182 F316	A182 F304	A182 F316	A182 F304L	A182 F316L
14	Stem	A182 F6a	17-4PH	A182 F304	A182 F316	A182 F304	A182 F316	A182 F304L	A182 F316L
15	Gland Flange	A216 WCB		A352 LCB		A351 CF8	A351 CF8M	A351 CF3	A351 CF3M
18	Seat Spring	17-7PH		17-7PH		Inconel X-750		Inconel X-750	
19	O Ring	VITON		VITON		VITON		VITON	
21	Drain Plug	AISI 1035	A182 F316	A182 F304	A182 F316	A182 F304	A182 F316	A182 F304L	A182 F316L
22	Worm Gear	Assembly		Assembly		Assembly		Assembly	
23	Slide Bearing	SS304+PTFE	SS316+PTFE	SS304+PTFE	SS316+PTFE	SS304+PTFE	SS316+PTFE	SS304+PTFE	SS316+PTFE
24	Thrust Bearing	SS304+PTFE	SS316+PTFE	SS304+PTFE	SS316+PTFE	SS304+PTFE	SS316+PTFE	SS304+PTFE	SS316+PTFE
25	Seal Ring	ASTM A105	ASTM A105N	A350 LF2		A182 F304	A182 F316	A182 F304L	A182 F316L
26	Top cover	A216 WCB		A352 LCB		A351 CF8	A351 CF8M	A351 CF3	A351 CF3M
27	Packing	Flexible Graphite		Flexible Graphite		PTFE		PTFE	
28	Packing Gland	A182 F6a	A182 F316	A182 F304	A182 F316	A182 F304	A182 F316	A182 F304L	A182 F316L
29	Yoke	A216 WCB		A216 WCB		A351 CF8		A351 CF8	
30	Key	AISI 1035		AISI 1035		A276 304		A276 304	
31	Relief Valve	Assembly		Assembly		Assembly		Assembly	
32	Grease Injector	Assembly		Assembly		Assembly		Assembly	

Information / restriction of technical rules need to be observed!  
Installation, Operating and Maintenance Manual can be downloaded at [www.comeval.es](http://www.comeval.es)

The engineer, designing a system or a plant, is responsible for the selection of the correct valve  
Product suitability must be verified, contact manufacturer for information

Main Valve Parameters - Class 150

SERIES BV BT ANSI RANGE

Nominal Size		inch	2"	2-1/2"	3"	4"	5"	6"	8"	10"	12"	14"
DN			50	65	80	100	125	150	200	250	300	350
End connection	RF	L	178	190	203	229	-	394	457	533	610	686
		ØB	51	65,375	76	102	128,25	152	203	254	305	337
		ØD	150	180	190	230	255	280	345	405	485	535
		ØK	120,7	139,7	152,4	190,5	215,9	241,3	298,5	362	431,8	476,3
		ØF	92,1	104,8	127	157,2	185,7	215,9	269,9	323,8	381	412,8
		C	14,3	15,9	17,5	22,3	22,3	23,9	27	28,6	30,2	33,4
		f	2	2	2	2	2	2	2	2	2	2
	n-Ød	4 - 3/4	4 - 3/4	4 - 3/4	8 - 3/4	8 - 7/8	8 - 7/8	8 - 7/8	12 - 1	12 - 1	12 - 1 1/8	
	BW	L1	216	241	282	305	-	457	521	559	635	762
		Schedule No.(1)	40	-	40	40	-	40	40	40	STD	STD
		ØB	51	65,375	76	102	128,25	152	203	254	305	337
		ØA1	60,3	-	91	117	-	172	223	278	329	362
		ØB1	52,48	-	78	102	-	154	203	254,5	305	336,5
	RTJ	L2	191	203	216	242	-	407	470	546	623	699
		ØB	51	65,375	76	102	128,25	152	203	254	305	337
		ØD	150	180	190	230	255	280	345	405	485	535
		ØK	120,7	139,7	152,4	190,5	215,9	241,3	298,5	362	431,8	476,3
		ØG	102	121	133	171	194	219	273	330	406	425
		ØP	82,55	101,6	114,3	149,23	171,45	193,68	247,65	304,8	381	396,88
		C	17,5	20,7	22,3	22,3	22,3	23,9	27	28,6	30,2	33,4
		n-Ød	4 - 3/4	4 - 3/4	4 - 3/4	8 - 3/4	8 - 7/8	8 - 7/8	8 - 7/8	12 - 1	12 - 1	12 - 1 1/8
		T	8,74	8,74	8,74	8,74	8,74	8,74	8,74	8,74	8,74	8,74
		S	6,35	6,35	6,35	6,35	6,35	6,35	6,35	6,35	6,35	6,35
		R	0,8	0,8	0,8	0,8	0,8	0,8	0,8	0,8	0,8	0,8
Top works/Operation		Lever	H	157	189	212	230	-	-	-	-	-
	G		85	113	133	144	-	-	-	-	-	-
	h		240	332	400	500	-	-	-	-	-	-
	Gear with handwheel	H1	238	262	280	295	365	416	482	545	618	651
		G	85	113	133	144	178	203	250	294	343	383
		h1	39	39	39	39	44	48	53	68	70	70
		J	76	88	96	96	107	115	139	170	192	192
		ØW	160	206	240	240	263	280	300	350	400	400
	With ISO 5211 mounting pad	H2	198	222	240	261	331	383	440	489	575	610
		G	85	113	133	144	178	203	250	294	343	383
		h2	30	33	35	40	49	55	55	69	85	87
		ISO	F07	F10	F10	F10	F12	F12	F14	F16	F20	F20
		Tr	20	24	24	28	35	35	40	48	60	60
		Torque (Nm) (2)	23	44	59	114	263	373	636	1000	1591	2364
		Kvs-value	-	-	-	-	-	-	-	-	-	-
Approx. Weight RF (3)	21	30	36	58	86	106	159	292	478	630		
Approx. Weight BW	18	25	31	50	75	93	137	263	434	574		

(1) Other schedule nos. on request  
 (2) Torque includes 30% of safety factor  
 (3) RTJ weight increases approx. by 10%

Dimensions in mm (except for bolt holes - Ød -, which are in inch units) subject to manufacturing tolerance  
 Kvs-values in m³/h / Torques in Nm / Weights in kg  
 For more information about flanged and welded ends refer to page 16

Main Valve Parameters - Class 150

SERIES BV BT ANSI RANGE

Nominal Size		inch	16"	18"	20"	24"	26"	28"	30"	32"	36"
DN		400	450	500	600	650	700	750	800	800	900
End connection	RF	L	762	864	914	1067	-	-	-	-	-
		ØB	387	438	489	591	633	684	735	779	874
		ØD	595	635	700	815	870	925	985	1060	1170
		ØK	539,8	577,9	635	749,3	806,4	863,6	914,4	977,9	1085,8
		ØF	469,9	533,4	584,2	692,2	749	800	857	914	1022
		C	35	38,1	41,3	46,1	66,7	69,9	73,1	79,4	88,9
		f	2	2	2	2	2	2	2	2	2
	n-Ød	16 - 1 1/8	16 - 1 1/4	20 - 1 1/4	20 - 1 3/8	24 - 1 3/8	28 - 1 3/8	28 - 1 3/8	28 - 1 3/8	28 - 1 5/8	32 - 1 5/8
	BW	L1	838	914	991	1143	1245	1346	1397	1524	1727
		Schedule No.(1)	STD	STD	STD	STD	20	20	20	20	20
		ØB	387	438	489	591	633	684	735	779	874
		ØA1	413	464	516	619	670	721	772	825	927
		ØB1	387,5	438	489	590,5	635	686	736,5	787,5	889
	RTJ	L2	775	877	927	1080	-	-	-	-	-
		ØB	387	438	489	591	633	684	735	779	874
		ØD	595	635	700	815	870	925	985	1060	1170
		ØK	539,8	577,9	635	749,3	806,4	863,6	914,4	977,9	1085,8
		ØG	483	546	597	711	810	861	917	984	1092
		ØP	454,03	517,53	558,8	673,1	749,3	800,1	857,25	914,4	1022,35
		C	35	38,1	41,3	46,1	66,7	69,9	73,1	79,4	88,9
		n-Ød	16 - 1 1/8	16 - 1 1/4	20 - 1 1/4	20 - 1 3/8	24 - 1 3/8	28 - 1 3/8	28 - 1 3/8	28 - 1 5/8	32 - 1 5/8
		T	8,74	8,74	8,74	8,74	19,84	19,84	19,84	23,01	23,01
		S	6,35	6,35	6,35	6,35	12,7	12,7	12,7	14,27	14,27
		R	0,8	0,8	0,8	0,8	1,5	1,5	1,5	1,5	1,5
	Top works/Operation	Lever	H	-	-	-	-	-	-	-	-
			G	-	-	-	-	-	-	-	-
			h	-	-	-	-	-	-	-	-
		Gear with handwheel	H1	764	900	941	1055	1097	1180	1233	1325
G			440	465	500	611	663	706	754	795	870
h1			80	50	50	60	60	60	60	65	65
J			224	305	305	380	380	384	384	516	516
ØW			500	500	500	500	500	600	600	600	600
With ISO 5211 mounting pad		H2	716	803	840	950	1007	1073	1150	1230	1340
		G	440	465	500	611	663	706	754	795	870
		h2	106	100	100	139	145	158	180	200	230
		ISO	F25	F30	F30	F35	F35	F40	F40	F48	F48
		Tr	70	80	80	90	100	110	120	130	140
		Torque (Nm) (2)	3545	5636	6818	9545	10970	13182	17960	19091	-
Kvs-value		-	-	-	-	-	-	-	-	-	
Approx. Weight RF (3)		895	1190	1405	2576	3305	3960	4902	6170	7690	
Approx. Weight BW		825	1113	1313	2434	3133	3738	4663	5864	7250	

(1) Other schedule nos. on request  
 (2) Torque includes 30% of safety factor  
 (3) RTJ weight increases approx. by 10%

Dimensions in mm (except for bolt holes - Ød -, which are in inch units) subject to manufacturing tolerance  
 Kvs-values in m³/h / Torques in Nm / Weights in kg  
 For more information about flanged and welded ends refer to page 16



Main Valve Parameters - Class 300

SERIES BV BT ANSI RANGE

Nominal Size		inch	2"	2-1/2"	3"	4"	5"	6"	8"	10"	12"	
DN			50	65	80	100	125	150	200	250	300	
End connection	RF	L	216	241	282	305		403	502	568	648	
		ØB	51	65,375	76	102	128,25	152	203	254	305	
		ØD	165	190	210	255	280	320	380	445	520	
		ØK	127	149,2	168,3	200	235	269,9	330,2	387,4	450,8	
		ØF	92,1	104,8	127	157,2	185,7	215,9	269,9	323,8	381	
		C	20,7	23,9	27	30,2	33,4	35	39,7	46,1	49,3	
		f	2	2	2	2	2	2	2	2	2	
		n-Ød	8 - 3/4	8 - 7/8	8 - 7/8	8 - 7/8	8 - 7/8	8 - 7/8	12 - 7/8	12 - 1	16 - 1 1/8	16 - 1 1/4
	BW	L1	216	241	282	305	-	457	521	559	635	
		Schedule No.(1)	40	-	40	40	-	40	40	40	STD	
		ØB	51	65,375	76	102	128,25	152	203	254	305	
		ØA1	60,3	-	91	117	-	172	223	278	329	
		ØB1	52,48	-	78	102	-	154	203	254,5	305	
	RTJ	L2	232	257	298	321	16	419	518	584	664	
		ØB	51	65,375	76	102	128,25	152	203	254	305	
		ØD	165	190	210	255	280	320	380	445	520	
		ØK	127	149,2	168,3	200	235	269,9	330,2	387,4	450,8	
		ØG	108	127	146	175	210	241	302	356	413	
		ØP	82,55	101,6	123,83	149,23	180,98	211,12	269,88	323,85	981	
		C	20,7	23,9	27	30,2	33,4	35	39,7	46,1	49,3	
		n-Ød	8 - 3/4	8 - 7/8	8 - 7/8	8 - 7/8	8 - 7/8	8 - 7/8	12 - 7/8	12 - 1	16 - 1 1/8	16 - 1 1/4
		T	11,91	11,91	11,91	11,91	11,91	11,91	11,91	11,91	11,91	11,91
		S	7,92	7,92	7,92	7,92	7,92	7,92	7,92	7,92	7,92	7,92
	R	0,8	0,8	0,8	0,8	0,8	0,8	0,8	0,8	0,8	0,8	
	Top works/Operation	Lever	H	157	189	212	230	-	-	-	-	-
			G	85	113	133	144	-	-	-	-	-
			h	240	332	400	500	-	-	-	-	-
		Gear with handwheel	H1	238	262	280	295	365	416	482	545	618
G			85	113	133	144	178	203	250	294	343	
h1			39	39	39	39	44	48	53	68	70	
J			76	88	96	96	107	115	139	170	192	
ØW			160	206	240	240	263	280	300	350	400	
With ISO 5211 mounting pad		H2	198	222	240	261	331	383	440	489	575	
		G	85	113	133	144	178	203	250	294	343	
		h2	30	33	35	40	49	55	55	69	85	
		ISO	F07	F10	F10	F10	F12	F12	F14	F16	F20	
		Tr	20	24	24	28	35	35	40	48	60	
		Torque (Nm) (2)	55	107	145	255	605	864	1409	1818	3000	
Kvs-value		-	-	-	-	-	-	-	-	-		
Approx. Weight RF (3)		26	39	49	76	108	131	219	412	610		
Approx. Weight BW		21	32	41	63	89	108	183	363	536		

(1) Other schedule nos. on request  
 (2) Torque includes 30% of safety factor  
 (3) RTJ weight increases approx. by 10%

Dimensions in mm (except for bolt holes - Ød -, which are in inch units) subject to manufacturing tolerance  
 Kvs-values in m³/h / Torques in Nm / Weights in kg  
 For more information about flanged and welded ends refer to page 16

Main Valve Parameters - Class 300

SERIES BV BT ANSI RANGE

Nominal Size		inch	14"	16"	18"	20"	24"	26"	28"	30"	32"	
DN			350	400	450	500	600	650	700	750	800	
End connection	RF	L	762	838	914	991	1143	1245	1346	1397	1524	
		ØB	337	387	432	483	584	633	684	735	779	
		ØD	585	650	710	775	915	970	1035	1090	1150	
		ØK	514,4	571,5	628,6	685,8	812,8	876,3	939,8	997	1054,1	
		ØF	412,8	469,9	533,4	584,2	692,2	749	800	857	914	
		C	52,4	55,6	58,8	62	68,3	77,8	84,2	90,5	96,9	
		f	2	2	2	2	2	2	2	2	2	
		n-Ød	20 - 1 1/4	20 - 1 3/8	24 - 1 3/8	24 - 1 3/8	24 - 1 5/8	28 - 1 3/4	28 - 1 3/4	28 - 1 7/8	28 - 2	
	BW	L1	762	838	914	991	1143	1245	1346	1397	1524	
		Schedule No.(1)	STD	STD	STD	STD	STD	20	20	20	20	
		ØB	337	387	432	483	584	633	684	735	779	
		ØA1	362	413	464	516	619	670	721	772	825	
		ØB1	336,5	387,5	438	489	590,5	635	686	736,5	787,5	
	RTJ	L2	778	854	930	1010	1165	1273	1371	1422	1552	
		ØB	337	387	432	483	584	633	684	735	779	
		ØD	585	650	710	775	915	970	1035	1090	1150	
		ØK	514,4	571,5	628,6	685,8	812,8	876,3	939,8	997	1054,1	
		ØG	457	508	575	635	749	810	861	917	984	
		ØP	419,1	469,9	533,4	584,2	692,15	749,3	800,1	857,25	914,4	
		C	52,4	55,6	58,8	62	68,3	77,8	84,2	90,5	96,9	
		n-Ød	20 - 1 1/4	20 - 1 3/8	24 - 1 3/8	24 - 1 3/8	24 - 1 5/8	28 - 1 3/4	28 - 1 3/4	28 - 1 7/8	28 - 2	
		T	11,91	11,91	11,91	13,49	16,66	19,84	19,84	19,84	23,01	
		S	7,92	7,92	7,92	9,53	11,13	12,7	12,7	12,7	14,27	
	R	0,8	0,8	0,8	1,5	1,5	1,5	1,5	1,5	1,5		
	Top works/Operation	Lever	H	-	-	-	-	-	-	-	-	-
			G	-	-	-	-	-	-	-	-	-
			h	-	-	-	-	-	-	-	-	-
		Gear with handwheel	H1	651	764	900	941	1055	1097	1180	1233	1325
G			383	440	465	500	611	663	706	754	795	
h1			70	80	50	50	60	60	60	60	65	
J			192	224	305	305	380	380	384	384	516	
ØW			400	500	500	500	500	500	600	600	600	
With ISO 5211 mounting pad		H2	610	716	803	840	950	1007	1073	1150	1230	
		G	383	440	465	500	611	663	706	754	795	
		h2	87	106	100	100	139	145	158	180	200	
		ISO	F20	F25	F30	F30	F35	F35	F40	F40	F48	
		Tr	60	70	80	80	90	100	110	120	130	
		Torque (Nm) (2)	4545	6818	10727	13091	17818	20509	25636	26795	27091	
	Kvs-value	-	-	-	-	-	-	-	-	-		
Approx. Weight RF (3)	809	1260	1510	1690	3175	4390	6210	7590	9300			
Approx. Weight BW	708	1127	1344	1485	2879	4044	5802	7103	8738			

(1) Other schedule nos. on request  
 (2) Torque includes 30% of safety factor  
 (3) RTJ weight increases approx. by 10%

Dimensions in mm (except for bolt holes - Ød -, which are in inch units) subject to manufacturing tolerance  
 Kvs-values in m³/h / Torques in Nm / Weights in kg  
 For more information about flanged and welded ends refer to page 16



Main Parts and Materials

SERIES BV BT ANSI RANGE  
Class 600 NPS2-4"

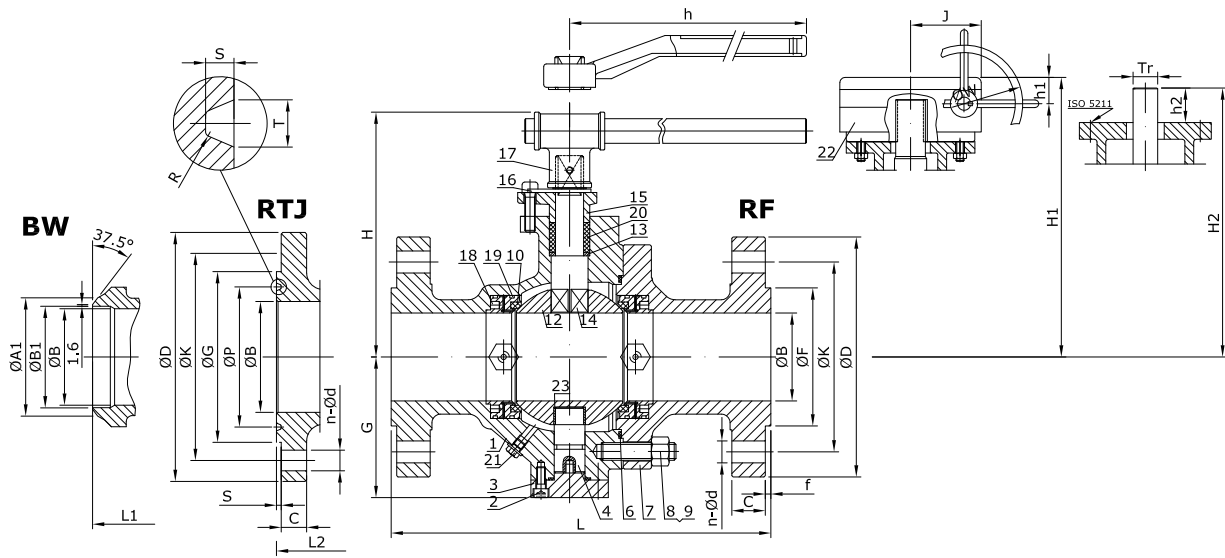

Nº	Part name	A216 WCB (BTA02_)	A216 WCB/ NACE (BTA02_)	A352 LCB/ SS304 (BTA82_)	A352 LCB/ SS316 (BTA83_)	A351 CF8 (BTI2_)	A351 CF8M (BTI0_)	A351 CF3 (BTI1_)	A351 CF3M (BTI7_)
1	Body	A216 WCB		A352 LCB		A351 CF8	A351 CF8M	A351 CF3	A351 CF3M
2	Screw	A193 B7	A193 B7M	A320 L7		A193 B8	A193 B8M	A193 B8M	A193 B8M
3	Bottom Cover	ASTM A105	ASTM A105N	A350 LF2		A182 F304	A182 F316	A182 F304L	A182 F316L
4	Trunnion	A182 F6a	17-4PH	A182 F304	A182 F316	A182 F304	A182 F316	A182 F304L	A182 F316L
6	Body Gasket	SS304 + Graphite	SS316 + Graphite	SS304 + Graphite	SS316 + Graphite	SS304 + Graphite	SS316 + Graphite	SS304 + Graphite	SS316 + Graphite
7	Body Cap	A216 WCB		A352 LCB		A351 CF8	A351 CF8M	A351 CF3	A351 CF3M
8	Body Bolt	A193 B7	A193 B7M	A320 L7		A193 B8	A193 B8M	A193 B8M	A193 B8M
9	Body Nut	A194 2H	A194 2HM	A194 4		A194 8	A194 8M	A194 8M	A194 8M
10	Seat	DEVLON		DEVLON		PEEK		PEEK	
11	Seat Retainer	ASTM A105	ASTM A105N	A350 LF2	A350 LF2	A182 F304	A182 F316	A182 F304L	A182 F316L
12	Ball	A105.ENP	A105N.ENP	A182 F304	A182 F316	A182 F304	A182 F316	A182 F304L	A182 F316L
13	Packing Gasket	A276 410	A276 316	A276 304	A276 316	A276 304	A276 316	A276 316	
14	Stem	A182 F6a	17-4PH	A182 F304	A182 F316	A182 F304	A182 F316	A182 F304L	A182 F316L
15	Gland Flange	A216 WCB		A352 LCB		A351 CF8	A351 CF8M	A351 CF3	A351 CF3M
16	Positioner Plate	AISI 1035		AISI 1035		Stainless Steel		Stainless Steel	
17	Lever	A216 WCB		A216 WCB		A216 WCB+Epoxy Coated			
18	Seat Spring	17-7PH		17-7PH		Inconel X-750		Inconel X-750	
19	O Ring	VITON		VITON		VITON		VITON	
20	Packing	Flexible Graphite		Flexible Graphite		PTFE		PTFE	
21	Drain Plug	AISI 1035	A182 F316	A182 F304	A182 F316	A182 F304	A182 F316	A182 F304L	A182 F316L
22	Worm Gear	Assembly		Assembly		Assembly		Assembly	
23	Slide Bearing	SS304+PTFE	SS316+PTFE	SS304+PTFE	SS316+PTFE	SS304(316)+PTFE		SS304(316)+PTFE	

Information / restriction of technical rules need to be observed!  
Installation, Operating and Maintenance Manual can be downloaded at [www.comeval.es](http://www.comeval.es)

The engineer, designing a system or a plant, is responsible for the selection of the correct valve  
Product suitability must be verified, contact manufacturer for information



Main Parts and Materials

SERIES BV BT ANSI RANGE  
Class 600 NPS10-12"

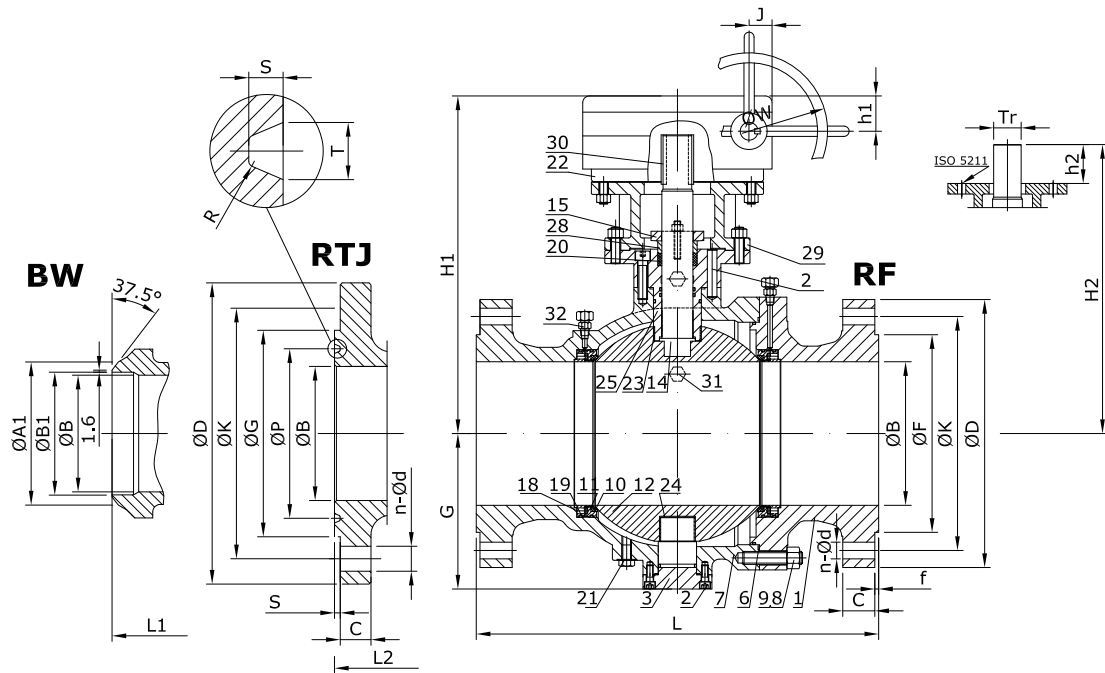

Nº	Part name	A216 WCB (BTA02_)	A216 WCB/ NACE (BTA02_)	A352 LCB/ SS304 (BTA82_)	A352 LCB/ SS316 (BTA83_)	A351 CF8 (BT12_)	A351 CF8M (BT10_)	A351 CF3 (BT11_)	A351 CF3M (BT17_)
1	Body	A216 WCB		A352 LCB		A351 CF8	A351 CF8M	A351 CF3	A351 CF3M
2	Screw	A193 B7	A193 B7M	A320 L7		A193 B8	A193 B8M	A193 B8M	
3	Bottom Cover	ASTM A105	ASTM A105N	A350 LF2		A182 F304	A182 F316	A182 F304L	A182 F316L
4	Trunnion	A182 F6a	17-4PH	A182 F304	A182 F316	A182 F304	A182 F316	A182 F304L	A182 F316L
6	Body Gasket	SS304 + Graphite	SS316 + Graphite	SS304 + Graphite	SS316 + Graphite	SS304 + Graphite	SS316 + Graphite	SS304 + Graphite	SS316 + Graphite
7	Body Cap	A216 WCB		A352 LCB		A351 CF8	A351 CF8M	A351 CF3	A351 CF3M
8	Body Bolt	A193 B7	A193 B7M	A320 L7		A193 B8	A193 B8M	A193 B8M	
9	Body Nut	A194 2H	A194 2HM	A194 4		A194 8	A194 8M	A194 8M	
10	Seat	DEVLON		DEVLON		PEEK		PEEK	
11	Seat Retainer	ASTM A105	ASTM A105N	A350 LF2		A182 F304	A182 F316	A182 F304L	A182 F316L
12	Ball	A105.ENP	A105N.ENP	A182 F304	A182 F316	A182 F304	A182 F316	A182 F304L	A182 F316L
14	Stem	A182 F6a	17-4PH	A182 F304	A182 F316	A182 F304	A182 F316	A182 F304L	A182 F316L
15	Gland Flange	A216 WCB		A352 LCB		A351 CF8	A351 CF8M	A351 CF3	A351 CF3M
18	Seat Spring	17-7PH		17-7PH		Inconel X-750		Inconel X-750	
19	O Ring	VITON		VITON		VITON		VITON	
20	Packing	Flexible Graphite		Flexible Graphite		PTFE		PTFE	
21	Drain Plug	AISI 1035	A182 F316	A182 F304	A182 F316	A182 F304	A182 F316	A182 F304L	A182 F316L
22	Worm Gear	Assembly		Assembly		Assembly		Assembly	
23	Slide Bearing	SS304 + PTFE	SS316 + PTFE	SS304 + PTFE	SS316 + PTFE	SS304 + PTFE	SS316 + PTFE	SS304 + PTFE	SS316 + PTFE
24	Thrust Bearing	SS304 + PTFE	SS316 + PTFE	SS304 + PTFE	SS316 + PTFE	SS304 + PTFE	SS316 + PTFE	SS304 + PTFE	SS316 + PTFE
25	Seal Ring	ASTM A105	ASTM A105N	A350 LF2		A182 F304	A182 F316	A182 F304L	A182 F316L
28	Packing Gland	A182 F6a	A182 F316	A182 F304	A182 F316	A182 F304	A182 F316	A182 F304L	A182 F316L
29	Yoke	A216 WCB		A216 WCB		A351 CF8		A351 CF8	
30	Key	AISI 1035		AISI 1035		A276 304		A276 304	
31	Relief Valve	Assembly		Assembly		Assembly		Assembly	
32	Grease Injector	Assembly		Assembly		Assembly		Assembly	

Information / restriction of technical rules need to be observed!  
Installation, Operating and Maintenance Manual can be downloaded at [www.comeval.es](http://www.comeval.es)

The engineer, designing a system or a plant, is responsible for the selection of the correct valve  
Product suitability must be verified, contact manufacturer for information

Main Parts and Materials

SERIES BV BT ANSI RANGE  
Class 600 NPS14-18"

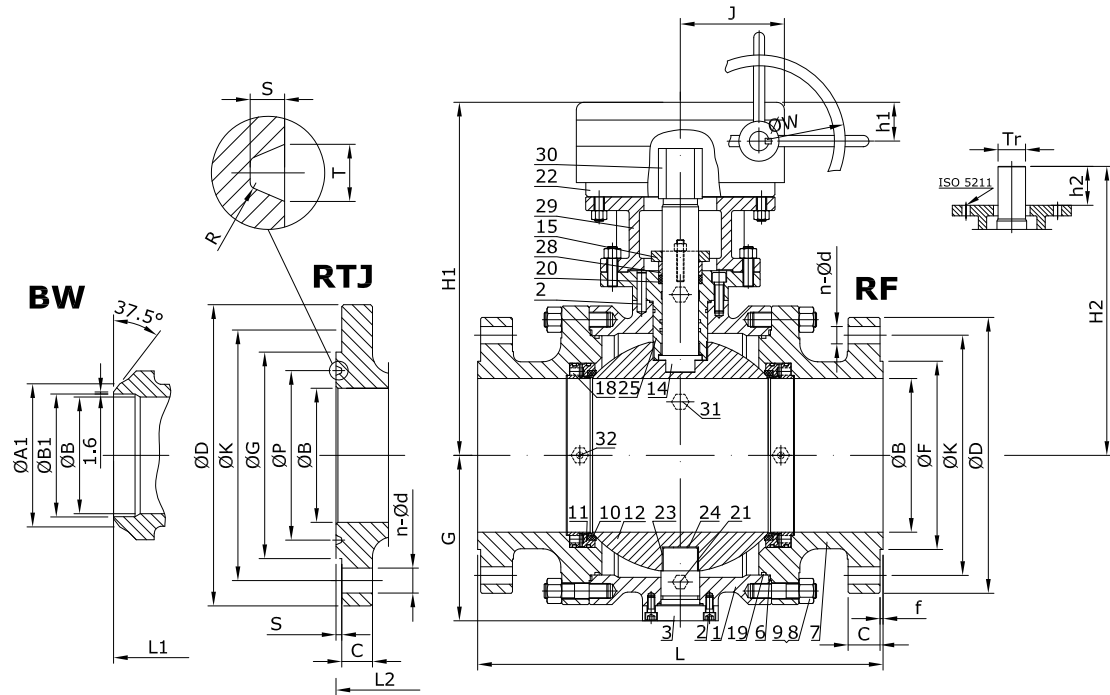

N°	Part name	A216 WCB (BTA02_)	A216 WCB/ NACE (BTA02_)	A352 LCB/ SS304 (BTA82_)	A352 LCB/ SS316 (BTA83_)	A351 CF8 (BT12_)	A351 CF8M (BT10_)	A351 CF3 (BT11_)	A351 CF3M (BT17_)
1	Body	A216 WCB		A352 LCB		A351 CF8	A351 CF8M	A351 CF3	A351 CF3M
2	Screw	A193 B7	A193 B7M	A320 L7		A193 B8	A193 B8M	A193 B8M	
3	Bottom Cover	ASTM A105	ASTM A105N	A350 LF2		A182 F304	A182 F316	A182 F304L	A182 F316L
4	Trunnion	A182 F6a	17-4PH	A182 F304	A182 F316	A182 F304	A182 F316	A182 F304L	A182 F316L
6	Body Gasket	SS304 + Graphite	SS316 + Graphite	SS304 + Graphite	SS316 + Graphite	SS304 + Graphite	SS316 + Graphite	SS304 + Graphite	SS316 + Graphite
7	Body Cap	A216 WCB		A352 LCB		A351 CF8	A351 CF8M	A351 CF3	A351 CF3M
8	Body Bolt	A193 B7	A193 B7M	A320 L7		A193 B8	A193 B8M	A193 B8M	
9	Body Nut	A194 2H	A194 2HM	A194 4		A194 8	A194 8M	A194 8M	
10	Seat	DEVLON		DEVLON		PEEK	PEEK		
11	Seat Retainer	ASTM A105	ASTM A105N	A350 LF2		A182 F304	A182 F316	A182 F304L	A182 F316L
12	Ball	A105.ENP	A105N.ENP	A182 F304	A182 F316	A182 F304	A182 F316	A182 F304L	A182 F316L
14	Stem	A182 F6a	17-4PH	A182 F304	A182 F316	A182 F304	A182 F316	A182 F304L	A182 F316L
15	Gland Flange	A216 WCB		A352 LCB		A351 CF8	A351 CF8M	A351 CF3	A351 CF3M
18	Seat Spring	17-7PH		17-7PH		Inconel X-750		Inconel X-750	
19	O Ring	VITON		VITON		VITON		VITON	
20	Packing	Flexible Graphite		Flexible Graphite		PTFE		PTFE	
21	Drain Plug	AISI 1035	A182 F316	A182 F304	A182 F316	A182 F304	A182 F316	A182 F304L	A182 F316L
22	Worm Gear	Assembly		Assembly		Assembly	Assembly		
23	Slide Bearing	SS304 + PTFE	SS316 + PTFE	SS304 + PTFE	SS316 + PTFE	SS304 + PTFE	SS316 + PTFE	SS304 + PTFE	SS316 + PTFE
24	Thrust Bearing	SS304 + PTFE	SS316 + PTFE	SS304 + PTFE	SS316 + PTFE	SS304 + PTFE	SS316 + PTFE	SS304 + PTFE	SS316 + PTFE
25	Seal Ring	ASTM A105	ASTM A105N	A350 LF2		A182 F304	A182 F316	A182 F304L	A182 F316L
28	Packing Gland	A182 F6a	A182 F316	A182 F304	A182 F316	A182 F304	A182 F316	A182 F304L	A182 F316L
29	Yoke	A216 WCB		A216 WCB		A351 CF8		A351 CF8	
30	Key	AISI 1035		AISI 1035		A276 304		A276 304	
31	Relief Valve	Assembly		Assembly		Assembly		Assembly	
32	Grease Injector	Assembly		Assembly		Assembly		Assembly	

Information / restriction of technical rules need to be observed!  
Installation, Operating and Maintenance Manual can be downloaded at [www.comeval.es](http://www.comeval.es)

The engineer, designing a system or a plant, is responsible for the selection of the correct valve  
Product suitability must be verified, contact manufacturer for information

Main Parts and Materials

SERIES BV BT ANSI RANGE  
Class 600 NPS20-28"

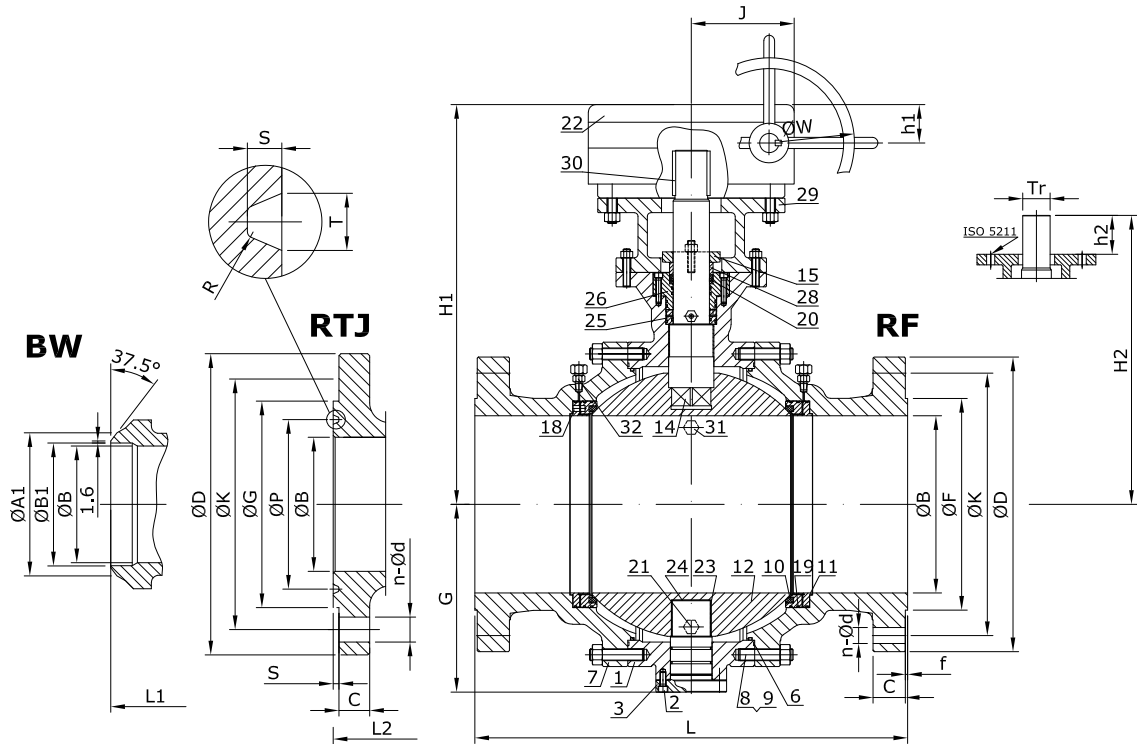

N°	Part name	A216 WCB (BTA02_)	A216 WCB/ NACE (BTA02_)	A352 LCB/ SS304 (BTA82_)	A352 LCB/ SS316 (BTA83_)	A351 CF8 (BT12_)	A351 CF8M (BT10_)	A351 CF3 (BT11_)	A351 CF3M (BT17_)
1	Body	A216 WCB		A352 LCB		A351 CF8	A351 CF8M	A351 CF3	A351 CF3M
2	Screw	A193 B7	A193 B7M	A320 L7		A193 B8	A193 B8M	A193 B8M	
3	Bottom Cover	ASTM A105	ASTM A105N	A350 LF2		A182 F304	A182 F316	A182 F304L	A182 F316L
4	Trunnion	A182 F6a	17-4PH	A182 F304	A182 F316	A182 F304	A182 F316	A182 F304L	A182 F316L
6	Body Gasket	SS304 + Graphite	SS316 + Graphite	SS304 + Graphite	SS316 + Graphite	SS304 + Graphite	SS316 + Graphite	SS304 + Graphite	SS316 + Graphite
7	Body Cap	A216 WCB		A352 LCB		A351 CF8	A351 CF8M	A351 CF3	A351 CF3M
8	Body Bolt	A193 B7	A193 B7M	A320 L7		A193 B8	A193 B8M	A193 B8M	
9	Body Nut	A194 2H	A194 2HM	A194 4		A194 8	A194 8M	A194 8M	
10	Seat	DEVLON		DEVLON		PEEK		PEEK	
11	Seat Retainer	ASTM A105	ASTM A105N	A350 LF2		A182 F304	A182 F316	A182 F304L	A182 F316L
12	Ball	A105.ENP	A105N.ENP	A182 F304	A182 F316	A182 F304	A182 F316	A182 F304L	A182 F316L
14	Stem	A182 F6a	17-4PH	A182 F304	A182 F316	A182 F304	A182 F316	A182 F304L	A182 F316L
15	Gland Flange	A216 WCB		A352 LCB		A351 CF8	A351 CF8M	A351 CF3	A351 CF3M
18	Seat Spring	17-7PH		17-7PH		Inconel X-750		Inconel X-750	
19	O Ring	VITON		VITON		VITON		VITON	
20	Packing	Flexible Graphite		Flexible Graphite		PTFE		PTFE	
21	Drain Plug	AISI 1035	A182 F316	A182 F304	A182 F316	A182 F304	A182 F316	A182 F304L	A182 F316L
22	Worm Gear	Assembly		Assembly		Assembly		Assembly	
23	Slide Bearing	SS304 + PTFE	SS316 + PTFE	SS304 + PTFE	SS316 + PTFE	SS304 + PTFE	SS316 + PTFE	SS304 + PTFE	SS316 + PTFE
24	Thrust Bearing	SS304 + PTFE	SS316 + PTFE	SS304 + PTFE	SS316 + PTFE	SS304 + PTFE	SS316 + PTFE	SS304 + PTFE	SS316 + PTFE
25	Seal Ring	ASTM A105	ASTM A105N	A350 LF2		A182 F304	A182 F316	A182 F304L	A182 F316L
26	Top cover	A216 WCB		A352 LCB		A351 CF8	A351 CF8M	A351 CF3	A351 CF3M
28	Packing Gland	A182 F6a	A182 F316	A182 F304	A182 F316	A182 F304	A182 F316	A182 F304L	A182 F316L
29	Yoke	A216 WCB		A216 WCB		A351 CF8		A351 CF8	
30	Key	AISI 1035		AISI 1035		A276 304		A276 304	
31	Relief Valve	Assembly		Assembly		Assembly		Assembly	
32	Grease Injector	Assembly		Assembly		Assembly		Assembly	

Information / restriction of technical rules need to be observed!  
Installation, Operating and Maintenance Manual can be downloaded at [www.comeval.es](http://www.comeval.es)

The engineer, designing a system or a plant, is responsible for the selection of the correct valve  
Product suitability must be verified, contact manufacturer for information

Main Valve Parameters - Class 600

SERIES BV BT ANSI RANGE

Nominal Size		inch	2"	2-1/2"	3"	4"	5"	6"	8"	10"
DN			50	65	80	100	125	150	200	250
End connection	RF	L	292	330	356	432		559	660	787
		ØB	51	65,375	76	102	128,25	152	200	248
		ØD	165	190	210	275	330	355	420	510
		ØK	127	149,2	168,3	215,9	266,7	292,1	349,2	431,8
		ØF	92,1	104,8	127	157,2	185,7	215,9	269,9	323,8
		C	25,4	28,6	31,8	38,1	44,5	47,7	55,6	63,5
		f	7	7	7	7	7	7	7	7
		n-Ød	8 - 3/4	8 - 7/8	8 - 7/8	8 - 1	8 - 1 1/8	12 - 1 1/8	12 - 1/4	16 - 1 3/8
	BW	L1	292	330	356	432		559	660	787
		Schedule No.(1)	80	-	80	80	-	80	80	80
		ØB	51	65,375	76	102	128,25	152	200	248
		ØA1	60,3	-	91	117	-	172	223	278
		ØB1	49,22	-	73,5	97	-	146,5	193,5	243
	RTJ	L2	295	333	359	435	3	562	663	790
		ØB	51	65,375	76	102	128,25	152	200	248
		ØD	165	190	210	275	330	355	420	510
		ØK	127	149,2	168,3	215,9	266,7	292,1	349,2	431,8
		ØG	108	127	146	175	210	241	302	356
		ØP	82,55	101,6	123,83	149,23	180,98	211,12	269,88	323,85
		C	25,4	28,6	31,8	38,1	44,5	47,7	55,6	63,5
		n-Ød	8 - 3/4	8 - 7/8	8 - 7/8	8 - 1	8 - 1 1/8	12 - 1 1/8	12 - 1/4	16 - 1 3/8
		T	11,91	11,91	11,91	11,91	11,91	11,91	11,91	11,91
		S	7,92	7,92	7,92	7,92	7,92	7,92	7,92	7,92
		R	0,8	0,8	0,8	0,8	0,8	0,8	0,8	0,8
Top works/Operation	Lever	H	186	207	222	279	-	-	-	-
		G	101	117	129	160	-	-	-	-
		h	400	458	500	600	-	-	-	-
	Gear with handwheel	H1	260	277	290	353	424	476	555	618
		G	101	117	129	160	188	208	242	277
		h1	40	40	40	48	60	68	30	40
		J	96	96	96	115	147	170	215	237
		ØW	240	240	240	280	320	350	320	350
	With ISO 5211 mounting pad	H2	221	241	256	310	376	425	475	530
		G	101	117	129	160	188	208	242	277
		h2	35	38	40	45	62	74	75	80
		ISO	F10	F10	F10	F12	F16	F16	F16	F20
		Tr	24	26	26	30	40	40	45	50
		Torque (Nm) (2)	173	314	418	700	1333	1800	2982	4773
Kvs-value		-	-	-	-	-	-	-	-	
Approx. Weight RF (3)		35	55	70	98	189	257	460	672	
Approx. Weight BW		28	45	57	75	154	213	396	569	

(1) Other schedule nos. on request  
 (2) Torque includes 30% of safety factor  
 (3) RTJ weight increases approx. by 10%

Dimensions in mm (except for bolt holes - Ød -, which are in inch units) subject to manufacturing tolerance  
 Kvs-values in m³/h / Torques in Nm / Weights in kg  
 For more information about flanged and welded ends refer to page 16

Main Valve Parameters - Class 600

SERIES BV BT ANSI RANGE

Nominal Size		inch	12"	14"	16"	18"	20"	24"	26"	28"	
DN			300	350	400	450	500	600	650	700	
End connection	RF	L	838	889	991	1092	1194	1397	1448	1549	
		ØB	299	327	375	419	464	559	603	648	
		ØD	560	605	685	745	815	940	1015	1075	
		ØK	489	527	603,2	654	723,9	838,2	914,4	965,2	
		ØF	381	412,8	469,9	533,4	584,2	692,2	749	800	
		C	66,7	69,9	76,2	82,6	88,9	101,6	108	111,2	
		f	7	7	7	7	7	7	7	7	
		n-Ød	20 - 1 3/8	20 - 1 1/2	20 - 1 5/8	20 - 1 3/4	24 - 1 3/4	24 - 2	28 - 2	28 - 2 1/8	
	BW	L1	838	889	991	1092	1194	1397	1448	1549	
		Schedule No.(1)	80	80	80	80	80	80	-	-	
		ØB	299	327	375	419	464	559	603	648	
		ØA1	329	362	413	464	516	619	-	-	
		ØB1	289	317,5	363,5	409,5	455,5	547,5	-	-	
	RTJ	L2	841	892	994	1095	1200	1407	1461	1562	
		ØB	299	327	375	419	464	559	603	648	
		ØD	560	605	685	745	815	940	1015	1075	
		ØK	489	527	603,2	654	723,9	838,2	914,4	965,2	
		ØG	413	457	508	575	635	749	810	861	
		ØP	981	419,1	469,9	533,4	584,2	692,15	749,3	800,1	
		C	66,7	69,9	76,2	82,6	88,9	101,6	108	111,2	
		n-Ød	20 - 1 3/8	20 - 1 1/2	20 - 1 5/8	20 - 1 3/4	24 - 1 3/4	24 - 2	28 - 2	28 - 2 1/8	
		T	11,91	11,91	11,91	11,91	13,49	16,66	19,84	19,84	
		S	7,92	7,92	7,92	7,92	9,53	11,13	12,7	12,7	
	R	0,8	0,8	0,8	0,8	1,5	1,5	1,5	1,5		
	Top works/Operation	Lever	H	-	-	-	-	-	-	-	-
			G	-	-	-	-	-	-	-	-
			h	-	-	-	-	-	-	-	-
		Gear with handwheel	H1	735	764	810	995	1055	1125	1155	1285
G			325	363	415	480	518	661	685	764	
h1			45	50	50	60	60	60	60	65	
J			275	305	305	380	380	384	384	516	
ØW			400	500	500	500	500	600	600	600	
With ISO 5211 mounting pad		H2	626	673	730	885	945	1040	1090	1203	
		G	325	363	415	480	518	661	685	764	
		h2	90	110	125	135	135	180	195	210	
		ISO	F25	F30	F30	F35	F35	F40	F40	F48	
		Tr	60	75	85	90	90	120	130	140	
		Torque (Nm) (2)	6545	8964	13182	17818	26364	38636	43960	52727	
Kvs-value		-	-	-	-	-	-	-	-		
Approx. Weight RF (3)		980	1330	1895	2513	3085	5610	7570	10190		
Approx. Weight BW		858	1150	1667	2225	2731	5172	6995	9544		

(1) Other schedule nos. on request  
 (2) Torque includes 30% of safety factor  
 (3) RTJ weight increases approx. by 10%

Dimensions in mm (except for bolt holes - Ød -, which are in inch units) subject to manufacturing tolerance  
 Kvs-values in m³/h / Torques in Nm / Weights in kg  
 For more information about flanged and welded ends refer to page 16



Main Parts and Materials

SERIES BV BT ANSI RANGE  
Class 900 NPS2-4"

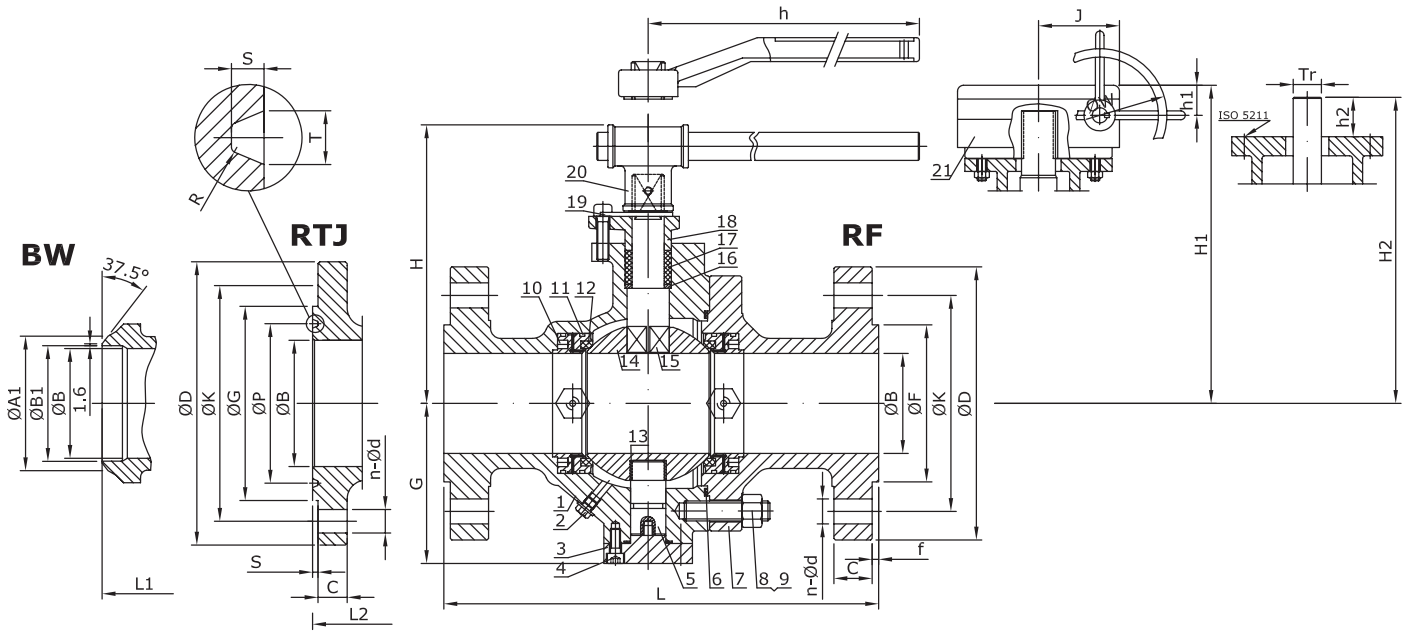

Nº	Part name	A216 WCB (BTA02_)	A216 WCB/ NACE (BTA02_)	A352 LCB/ SS304 (BTA82_)	A352 LCB/ SS316 (BTA83_)	A351 CF8 (BTI2_)	A351 CF8M (BTI0_)	A351 CF3 (BTI1_)	A351 CF3M (BTI7_)
1	Body	A216 WCB		A352 LCB		A351 CF8	A351 CF8M	A351 CF3	A351 CF3M
2	Drain Plug	AISI 1035	A182 F316	A182 F304	A182 F316	A182 F304	A182 F316	A182 F304L	A182 F316L
3	Bottom Cover	A105	A105N	A350 LF2		A182 F304	A182 F316	A182 F304L	A182 F316L
4	Screw	A193 B7	A193 B7M	A320 L7		A193 B8	A193 B8M	A193 B8M	
5	Trunnion	A182 F6a	17-4PH	A182 F304	A182 F316	A182 F304	A182 F316	A182 F304L	A182 F316L
6	Body Gasket	SS304+ Graphite	SS316+ Graphite	SS304+ Graphite	SS316+ Graphite	SS304+ Graphite	SS316+ Graphite	SS304+ Graphite	SS316+ Graphite
7	Body Cap	A216 WCB		A352 LCB		A351 CF8	A351 CF8M	A351 CF3	A351 CF3M
8	Body Bolt	A193 B7	A193 B7M	A320 L7	A320 L7	A193 B8	A193 B8M	A193 B8M	
9	Body Nut/	A194 2H	A194 2HM	A194 4	A194 4	A194 8	A194 8M	A194 8M	
10	Seat Spring	17-7PH		17-7PH		Inconel X-750		Inconel X-750	
11	O Ring	VITON		VITON		VITON		VITON	
12	Seat	DEVLON		DEVLON		PEEK		PEEK	
13	Slide Bearing	SS304+PTFE	SS316+PTFE	SS304+PTFE	SS316+PTFE	SS304+PTFE	SS316+PTFE	SS304+PTFE	SS316+PTFE
14	Ball	A105.ENP	A105N.ENP	A182 F304	A182 F316	A182 F304	A182 F316	A182 F304L	A182 F316L
15	Stem	A182 F6a	17-4PH	A182 F304	A182 F316	A182 F304	A182 F316	A182 F304L	A182 F316L
16	Packing Gasket	A276 410	A276 316	A276 304	A276 316	A276 304	A276 316	A276 316	A276 316
17	Packing	Flexible Graphite		Flexible Graphite		PTFE		PTFE	
18	Gland Flange	A216 WCB		A352 LCB		A351 CF8	A351 CF8M	A351 CF3	A351 CF3M
19	Positioner	AISI 1035		AISI 1035		Stainless Steel		Stainless Steel	
20	Lever	A216 WCB		A216 WCB		A216 WCB+Epoxy Coated		A216 WCB+Epoxy Coated	
21	Worm Gear	Assembly		Assembly		Assembly		Assembly	

Main Parts and Materials

SERIES BV BT ANSI RANGE  
Class 900 NPS6"

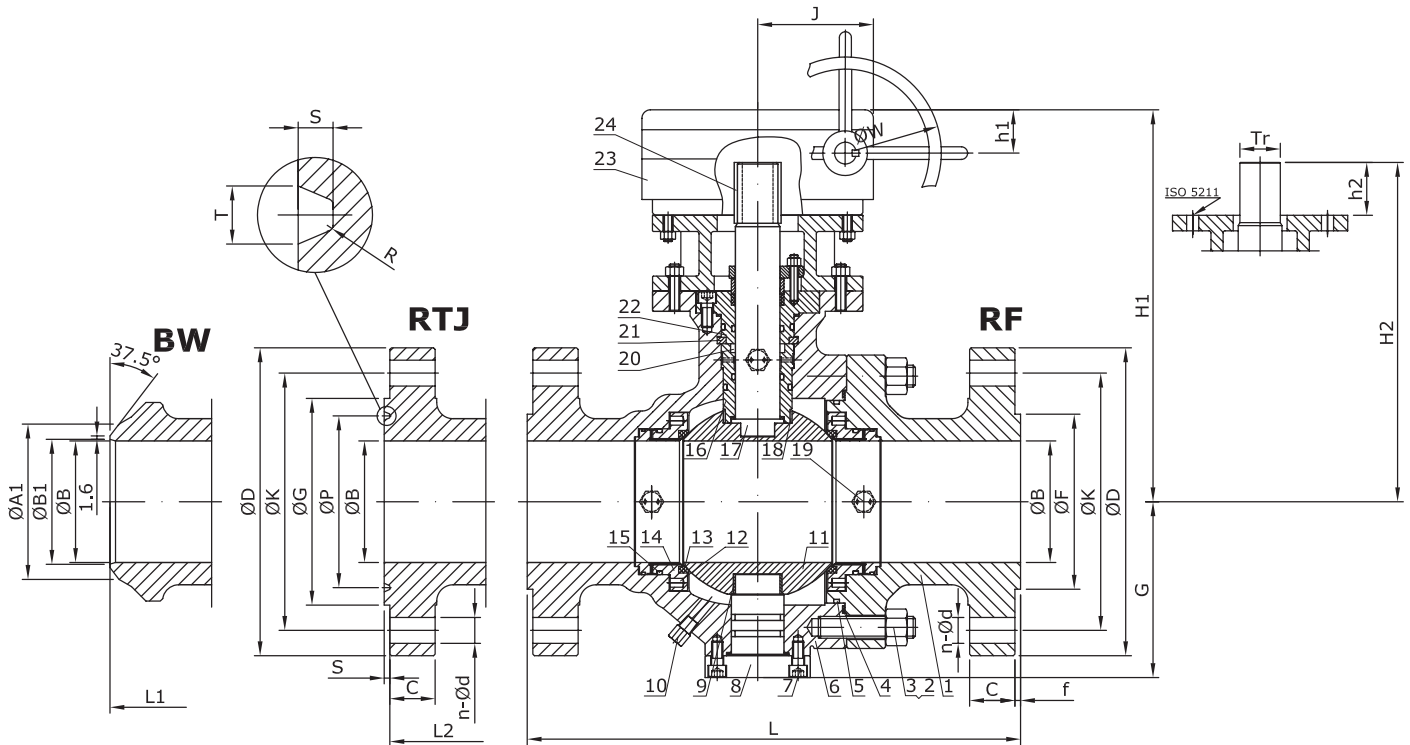

Nº	Part name	A216 WCB (BTA02_)	A216 WCB/ NACE (BTA02_)	A352 LCB/ SS304 (BTA82_)	A352 LCB/ SS316 (BTA83_)	A351 CF8 (BT12_)	A351 CF8M (BT10_)	A351 CF3 (BT11_)	A351 CF3M (BT17_)
1	Body Cap	A216 WCB		A352 LCB		A351 CF8	A351 CF8M	A351 CF3	A351 CF3M
2	Body Bolt	A193 B7	A193 B7M	A320 L7		A193 B8	A193 B8M	A193 B8M	
3	Body Nut	A194 2H	A194 2HM	A194 4		A194 8	A194 8M	A194 8M	
4	Body Gasket	SS304+ Graphite	SS316+ Graphite	SS304+ Graphite	SS316+ Graphite	SS304+ Graphite	SS316+ Graphite	SS304+ Graphite	SS316+ Graphite
5	O Ring	VITON			VITON			VITON	
6	Body	A216 WCB		A352 LCB		A351 CF8	A351 CF8M	A351 CF3	A351 CF3M
7	Screw	A193 B7	A193 B7M	A320 L7		A193 B8	A193 B8M	A193 B8M	
8	Bottom Cover	A105	A105N	A350 LF2		A182 F304	A182 F316	A182 F304L	A182 F316L
9	Slide Bearing	SS304+PTFE	SS316+PTFE	SS304+PTFE	SS316+PTFE	SS304+PTFE	SS316+PTFE	SS304+PTFE	SS316+PTFE
10	Drain Plug	AISI 1035	A182 F316	A182 F304	A182 F316	A182 F304	A182 F316	A182 F304L	A182 F316L
11	Ball	A105.ENP	A105N.ENP	A182 F304	A182 F316	A182 F304	A182 F316	A182 F304L	A182 F316L
12	Seat Spring	17-7PH		17-7PH		Inconel X-750		Inconel X-750	
13	Seat	DEVLON			DEVLON		PEEK		PEEK
14	Seat Retainer	A105	A105N	A350 LF2		A182 F304	A182 F316	A182 F304L	A182 F316L
15	O Ring	VITON			VITON		VITON		VITON
16	Seal Ring	A105	A105N	A350 LF2		A182 F304	A182 F316	A182 F304L	A182 F316L
17	Stem	A182 F6a	17-4PH	A182 F304	Nitronic 50	A182 F304	Nitronic 50	A182 F304L	Nitronic 50
18	Slide Bearing	SS304+PTFE	SS316+PTFE	SS304+PTFE	SS316+PTFE	SS304+PTFE	SS316+PTFE	SS304+PTFE	SS316+PTFE
19	Grease Injector	Assembly		Assembly		Assembly		Assembly	
20	Gasket	A276 410	A276 316	A276 304	A276 316	A276 304	A276 316	A276 316	A276 316
21	Split Ring	A105	A105N	A350 LF2		A182 F304	A182 F316	A182 F304L	A182 F316L
22	Top cover	A216 WCB		A352 LCB		A351 CF8	A351 CF8M	A351 CF3	A351 CF3M
23	Worm Gear	Assembly			Assembly		Assembly		Assembly
24	Key	AISI 1035		AISI 1035		A276 304		A276 304	

Information / restriction of technical rules need to be observed!  
Installation, Operating and Maintenance Manual can be downloaded at [www.comeval.es](http://www.comeval.es)

The engineer, designing a system or a plant, is responsible for the selection of the correct valve  
Product suitability must be verified, contact manufacturer for information

Main Parts and Materials

SERIES BV BT ANSI RANGE  
Class 900 NPS8-24"

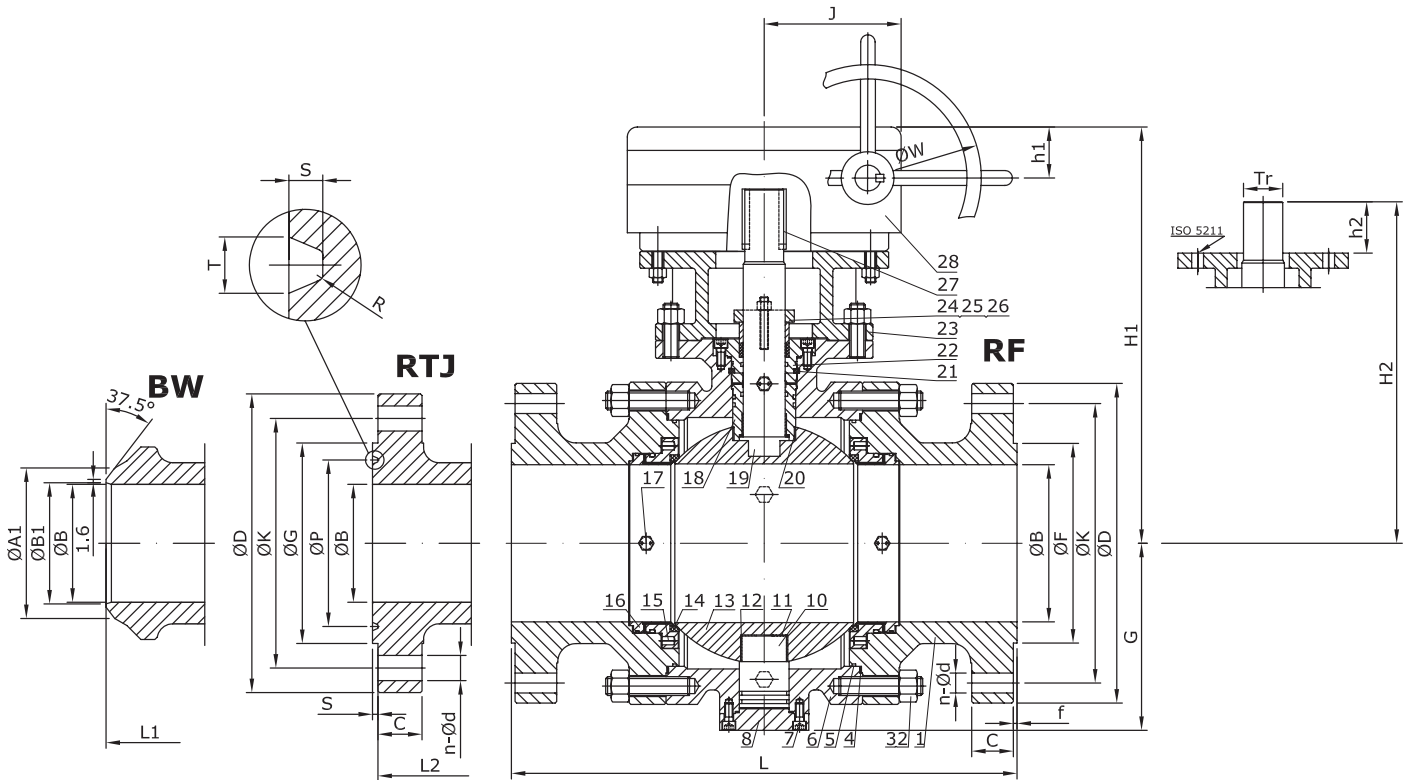

N°	Part name	A216 WCB (BTA02_)	A216 WCB/ NACE (BTA02_)	A352 LCB/ SS304 (BTA82_)	A352 LCB/ SS316 (BTA83_)	A351 CF8 (BT12_)	A351 CF8M (BT10_)	A351 CF3 (BT11_)	A351 CF3M (BT17_)
1	Body Cap	A216 WCB		A352 LCB		A351 CF8	A351 CF8M	A351 CF3	A351 CF3M
2	Body Bolt	A193 B7	A193 B7M	A320 L7		A193 B8	A193 B8M	A193 B8M	
3	Body Nut	A194 2H	A194 2HM	A194 4		A194 8	A194 8M	A194 8M	
4	Body Gasket	SS304+ Graphite	SS316+ Graphite	SS304+ Graphite	SS316+ Graphite	SS304+ Graphite	SS316+ Graphite	SS304+ Graphite	SS316+ Graphite
5	O Ring	VITON		VITON		VITON		VITON	
6	Body	A216 WCB		A352 LCB		A351 CF8	A351 CF8M	A351 CF3	A351 CF3M
7	Screw	A193 B7	A193 B7M	A320 L7		A193 B8	A193 B8M	A193 B8M	
8	Bottom Cover	A105	A105N	A350 LF2		A182 F304	A182 F316	A182 F304L	A182 F316L
9	Drain Plug	AISI 1035	A182 F316	A182 F304	A182 F316	A182 F304	A182 F316	A182 F304L	A182 F316L
10	Trunnion	A182 F6a	17-4PH	A182 F304	A182 F316	A182 F304	A182 F316	A182 F304L	A182 F316L
11	Thrust Bearing	SS304+PTFE	SS316+PTFE	SS304+PTFE	SS316+PTFE	SS304+PTFE	SS316+PTFE	SS304+PTFE	SS316+PTFE
12	Slide Bearing	SS304+PTFE	SS316+PTFE	SS304+PTFE	SS316+PTFE	SS304+PTFE	SS316+PTFE	SS304+PTFE	SS316+PTFE
13	Ball	A105.ENP	A105N.ENP	A182 F304	A182 F316	A182 F304	A182 F316	A182 F304L	A182 F316L
14	Seat	DEVLON		DEVLON		PEEK		PEEK	
15	Seat Spring	17-7PH		17-7PH		Inconel X-750		Inconel X-750	
16	Seat Retainer	A105	A105N	A350 LF2		A182 F304	A182 F316	A182 F304L	A182 F316L
17	Grease Injector	Assembly		Assembly		Assembly		Assembly	
18	Seal Ring	A105	A105N	A350 LF2		A182 F304	A182 F316	A182 F304L	A182 F316L
19	Stem	A182 F6a	17-4PH	A182 F304	Nitronic 50	A182 F304	Nitronic 50	A182 F304L	Nitronic 50
20	Slide Bearing	SS304+PTFE	SS316+PTFE	SS304+PTFE	SS316+PTFE	SS304+PTFE	SS316+PTFE	SS304+PTFE	SS316+PTFE
21	Split Ring	A105	A105N	A350 LF2		A182 F304	A182 F316	A182 F304L	A182 F316L
22	Top cover	A216 WCB		A352 LCB		A351 CF8	A351 CF8M	A351 CF3	A351 CF3M
23	Yoke	A216 WCB		A216 WCB		A351 CF8		A351 CF8	
24	Packing	Flexible Graphite		Flexible Graphite		PTFE		PTFE	
25	Packing Gland	A182 F6a	A182 F316	A182 F304	A182 F316	A182 F304	A182 F316	A182 F304L	A182 F316L
26	Gland Flange	A216 WCB		A352 LCB		A351 CF8	A351 CF8M	A351 CF3	A351 CF3M
27	Key	AISI 1035		AISI 1035		A276 304		A276 304	
28	Worm Gear	Assembly		Assembly		Assembly		Assembly	

Information / restriction of technical rules need to be observed!  
Installation, Operating and Maintenance Manual can be downloaded at [www.comeval.es](http://www.comeval.es)

The engineer, designing a system or a plant, is responsible for the selection of the correct valve  
Product suitability must be verified, contact manufacturer for information

Main Valve Parameters - Class 900

Nominal Size		inch	2"	2-1/2"	3"	4"	5"	6"	8"	
		DN	50	65	80	100	125	150	200	
End connection	RF	L	368	419	381	457		610	737	
		ØB	48	62,375	73	98	123,2	146	191	
		ØD	215	245	240	290	350	380	470	
		ØK	165,1	190,5	190,5	235	279,4	317,5	393,7	
		ØF	92,1	104,8	127	157,2	185,7	215,9	269,9	
		C	38,1	41,3	38,1	44,5	50,8	55,6	63,5	
		f	7	7	7	7	7	7	7	
		n-Ød	8 - 7/8	8 - 1	8 - 7/8	8 - 1 1/8	8 - 1 1/4	12 - 1 1/8	12 - 1 3/8	
	BW	L1	368	419	381	457		610	737	
		Schedule No.(1)	160	-	160	120	-	120	100	
		ØB	48	62,375	73	98	123,2	146	191	
		ØA1	60,3	-	91	117	-	172	223	
		ØB1	38,16	-	66,5	92	-	140	189	
	RTJ	L2	371	422	384	460	3	613	740	
		ØB	48	62,375	73	98	123,2	146	191	
		ØD	215	245	240	290	350	380	470	
		ØK	165,1	190,5	190,5	235	279,4	317,5	393,7	
		ØG	124	137	156	181	216	241	308	
		ØP	95,25	107,95	123,83	149,23	180,98	211,12	269,88	
		C	38,1	41,3	38,1	44,5	50,8	55,6	63,5	
		n-Ød	8 - 7/8	8 - 1	8 - 7/8	8 - 1 1/8	8 - 1 1/4	12 - 1 1/8	12 - 1 3/8	
		T	11,91	11,91	11,91	11,91	11,91	11,91	11,91	
		S	7,92	7,92	7,92	7,92	7,92	7,92	7,92	
		R	0,8	0,8	0,8	0,8	0,8	0,8	0,8	
		Top works/Operation	Lever	H	191	207	232	-	-	-
	G			107	117	137	-	-	-	-
	h			400	458	500	-	-	-	-
	Gear with handwheel		H1	265	277	304	377	424	559	661
G			107	117	137	160	188	217	275	
h1			40	40	40	53	60	80	45	
J			96	96	96	139	147	224	275	
ØW			240	240	240	300	320	500	400	
With ISO 5211 mounting pad	H2		226	241	270	337	376	480	577	
	G		107	117	137	160	188	217	275	
	h2		35	38	40	57	62	75	115	
	ISO		F10	F10	F10	F14	F16	F25	F25	
	Tr		24	26	28	32	40	50	70	
	Torque (Nm) (2)		213	314	732	866	1333	2335	3792	
	Kvs-value		-	-	-	-	-	-	-	
Approx. Weight RF (3)	42	55	97	150	189	330	590			
Approx. Weight BW	28	45	80	122	154	270	488			

(1) Other schedule nos. on request  
 (2) Torque includes 30% of safety factor  
 (3) RTJ weight increases approx. by 10%

Dimensions in mm (except for bolt holes - Ød -, which are in inch units) subject to manufacturing tolerance  
 Kvs-values in m³/h / Torques in Nm / Weights in kg  
 For more information about flanged and welded ends refer to page 16

Main Valve Parameters - Class 900

SERIES BV BT ANSI RANGE

Nominal Size		inch	10"	12"	14"	16"	18"	20"	24"	
DN			250	300	350	400	450	500	600	
End connection	RF	L	838	965	1029	1130	1219	1321	1549	
		ØB	238	282	311	356	400	445	533	
		ØD	545	610	640	705	785	855	1040	
		ØK	469,9	533,4	558,8	616	685,8	749,3	901,7	
		ØF	323,8	381	412,8	469,9	533,4	584,2	692,2	
		C	69,9	79,4	85,8	88,9	101,6	108	139,7	
		f	7	7	7	7	7	7	7	
		n-Ød	16 - 1 3/8	20 - 1 3/8	20 - 1 1/2	20 - 1 5/8	20 - 1 7/8	20 - 2	20 - 2 1/2	
	BW	L1	838	965	1029	1130	1219	1321	1549	
		Schedule No.(1)	100	100	100	100	100	100	100	
		ØB	238	282	311	356	400	445	533	
		ØA1	278	329	362	413	464	516	619	
		ØB1	236,5	281	308	354	398,5	443	532	
	RTJ	L2	841	968	1039	1140	1232	1334	1568	
		ØB	238	282	311	356	400	445	533	
		ØD	545	610	640	705	785	855	1040	
		ØK	469,9	533,4	558,8	616	685,8	749,3	901,7	
		ØG	362	419	467	524	594	648	772	
		ØP	323,85	381	419,1	469,9	533,4	584,2	692,15	
		C	69,9	79,4	85,8	88,9	101,6	108	139,7	
		n-Ød	16 - 1 3/8	20 - 1 3/8	20 - 1 1/2	20 - 1 5/8	20 - 1 7/8	20 - 2	20 - 2 1/2	
		T	11,91	11,91	16,66	16,66	19,84	19,84	26,97	
		S	7,92	7,92	11,13	11,13	12,7	12,7	15,88	
	R	0,8	0,8	1,5	1,5	1,5	1,5	2,4		
	Top works/Operation	Lever	H	-	-	-	-	-	-	-
			G	-	-	-	-	-	-	-
			h	-	-	-	-	-	-	-
		Gear with handwheel	H1	715	755	847	892	968	1023	1149
G			317	357	400	445	510	533	625	
h1			50	50	60	60	60	60	60	
J			305	305	380	380	380	384	384	
ØW			500	500	500	500	500	600	600	
With ISO 5211 mounting pad		H2	619	672	747	797	872	900	1080	
		G	317	357	400	445	510	533	625	
		h2	115	120	145	150	150	165	195	
		ISO	F30	F30	F35	F35	F35	F40	F40	
		Tr	70	75	90	105	115	115	130	
		Torque (Nm) (2)	5713	6756	10777	16707	23223	35369	52377	
		Kvs-value	-	-	-	-	-	-	-	
Approx. Weight RF (3)	812	1370	1680	2310	3140	3690	6494			
Approx. Weight BW	670	1174	1457	2041	2780	3242	5678			

(1) Other schedule nos. on request  
 (2) Torque includes 30% of safety factor  
 (3) RTJ weight increases approx. by 10%

Dimensions in mm (except for bolt holes - Ød -, which are in inch units) subject to manufacturing tolerance  
 Kvs-values in m³/h / Torques in Nm / Weights in kg  
 For more information about flanged and welded ends refer to page 16



Main Parts and Materials

SERIES BV B9 ANSI RANGE  
Class 1500 NPS6-16"

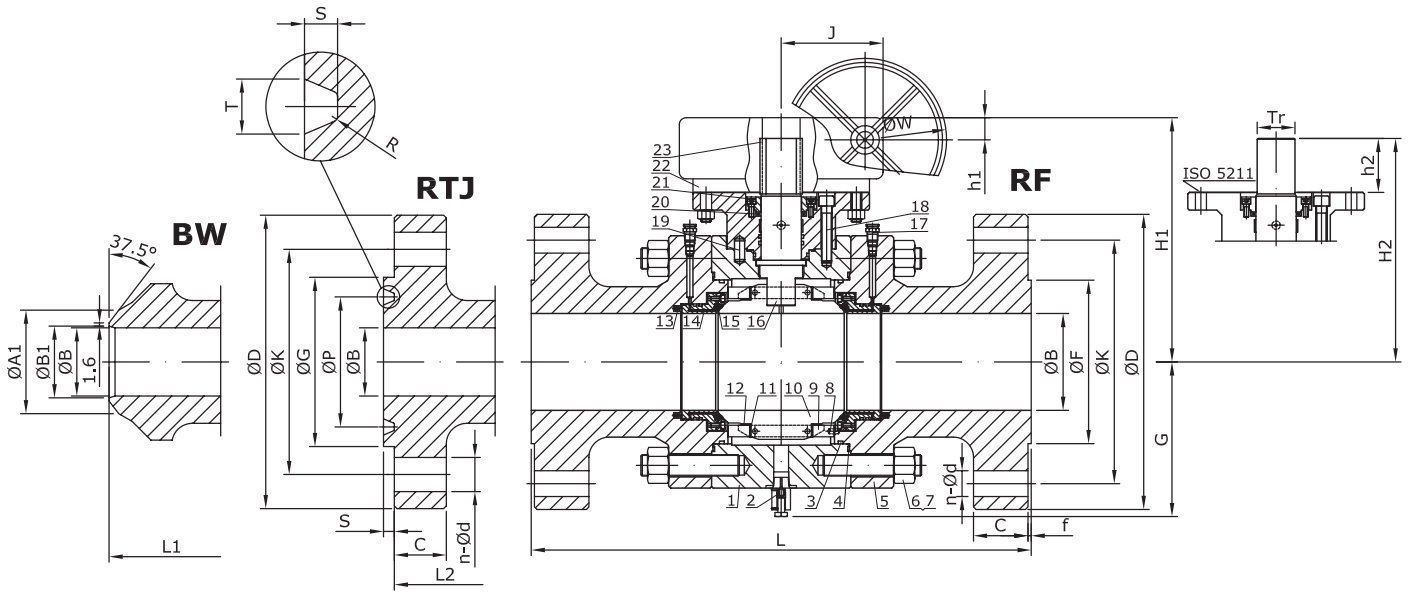

Nº	Part name	A105 (B9A02_)	A105/NACE (B9A02_)	A350 LF2/ SS304 (B9A1_)	A350 LF2/ SS316 (B9A1_)	A182 F304 (B9I1_)	A182 F316 (B9I3_)	A182 F304L (B9I9_)	A182 F316 (B9J1_)
1	Body	ASTM A105	ASTM A105N	A350 LF2		A182 F304	A182 F316	A182 F304L	A182 F316L
2	Drain Plug	AISI 1035	A182 F316	A182 F304	A182 F316	A182 F304	A182 F316	A182 F304L	A182 F316L
3	O Ring	VITON			VITON		VITON		VITON
4	Body Gasket	SS304+ Graphite	SS316+ Graphite	SS304+ Graphite	SS316+ Graphite	SS304+ Graphite	SS316+ Graphite	SS304+ Graphite	SS316+ Graphite
5	Body Cap	ASTM A105	ASTM A105N	A350 LF2		A182 F304	A182 F316	A182 F304L	A182 F316L
6	Body Bolt	A193 B7	A193 B7M	A320 L7		A193 B8	A193 B8M	A193 B8M	
7	Body Nut	A194 2H	A194 2HM	A194 4		A194 8	A194 8M	A194 8M	
8	Screw	A193 B7	A193 B7M	A320 L7		A193 B8	A193 B8M	A193 B8M	
9	Ball Supporter	ASTM A105	ASTM A105N	A350 LF2		A182 F304	A182 F316	A182 F304L	A182 F316L
10	Ball	A105.ENP	A105N.ENP	A182 F304	A182 F316	A182 F304	A182 F316	A182 F304L	A182 F316L
11	Slide Bearing	SS304+PTFE	SS316+PTFE	SS304+PTFE	SS316+PTFE	SS304+PTFE	SS316+PTFE	SS304+PTFE	SS316+PTFE
12	Thrust Bearing	SS304+PTFE	SS316+PTFE	SS304+PTFE	SS316+PTFE	SS304+PTFE	SS316+PTFE	SS304+PTFE	SS316+PTFE
13	Seat Spring	17-7PH		17-7PH		Inconel X-750		Inconel X-750	
14	Seat Retainer	ASTM A105	ASTM A105N	A350 LF2		A182 F304	A182 F316	A182 F304L	A182 F316L
15	Seat	DEVLON			DEVLON		PEEK		PEEK
16	Stem	A182 F6a	17-4PH	A182 F304	Nitronic 50	A182 F304	Nitronic 50	A182 F304L	Nitronic 50
17	Grease Injector	Assembly			Assembly		Assembly		Assembly
18	Screw	A193 B7	A193 B7M	A320 L7		A193 B8	A193 B8M	A193 B8M	
19	Screw	A193 B7	A193 B7M	A320 L7		A193 B8	A193 B8M	A193 B8M	
20	Packing	Flexible Graphite			Flexible Graphite		PTFE		PTFE
21	Gland Flange	ASTM A105	ASTM A105N	A350 LF2		A182 F304	A182 F316	A182 F304L	A182 F316L
22	Worm Gear	Assembly			Assembly		Assembly		Assembly
23	Key	AISI 1035			AISI 1035		A276 304		A276 304



Main Valve Parameters - Class 1500

Nominal Size		inch	2"	2-1/2"	3"	4"	5"	6"	8"	10"	12"	14"	16"	
DN			50	65	80	100	125	150	200	250	300	350	400	
End connection	RF	L	368	419	470	546		705	832	991	1130	1257	1384	
		ØB	48	60,65	70	92	115,1	136	178	222	263	289	330	
		ØD	215	245	265	310	375	395	485	585	675	750	825	
		ØK	165,1	190,5	203,2	241,3	292,1	317,5	393,7	482,6	571,5	635	704,8	
		ØF	92,1	104,8	127	157,2	185,7	215,9	269,9	323,8	381	412,8	469,9	
		C	38,1	41,3	47,7	54	73,1	82,6	92,1	108	123,9	133,4	146,1	
		f	7	7	7	7	7	7	7	7	7	7	7	7
	n-Ød	8 - 7/8	8 - 1	8 - 1 1/4	8 - 1 3/8	8 - 1 5/8	12 - 1 1/2	12 - 1 3/4	12 - 2	16 - 2 1/8	16 - 2 3/8	16 - 2 5/8		
	BW	L1	368	419	470	546		705	832	991	1130	1257	1384	
		Schedule No.(1)	160	-	160	120	-	120	120	120	120	120	120	
		ØB	48	60,65	70	92	115,1	136	178	222	263	289	330	
		ØA1	60,3	-	91	117	-	172	223	278	329	362	413	
		ØB1	38,16	-	66,5	92	-	140	182,5	230	273	300	344,5	
	RTJ	L2	371	422	473	549	3	711	842	1001	1146	1276	1406	
		ØB	48	60,65	70	92	115,1	136	178	222	263	289	330	
		ØD	215	245	265	310	375	395	485	585	675	750	825	
		ØK	165,1	190,5	203,2	241,3	292,1	317,5	393,7	482,6	571,5	635	704,8	
		ØG	124	137	168	194	229	248	318	371	438	489	546	
		ØP	95,25	107,95	136,53	161,93	193,68	211,14	269,88	323,85	381	419,1	469,9	
		C	38,1	41,3	47,7	54	73,1	82,6	92,1	108	123,9	133,4	146,1	
		n-Ød	8 - 7/8	8 - 1	8 - 1 1/4	8 - 1 3/8	8 - 1 5/8	12 - 1 1/2	12 - 1 3/4	12 - 2	16 - 2 1/8	16 - 2 3/8	16 - 2 5/8	
		T	11,91	11,91	11,91	11,91	11,91	13,49	16,66	16,66	23,01	26,97	30,18	
		S	7,92	7,92	7,92	7,92	7,92	9,53	11,13	11,13	14,27	15,88	17,48	
		R	0,8	0,8	0,8	0,8	0,8	1,5	1,5	1,5	1,5	2,4	2,4	
	Top works/Operation	Lever	H	222	-	-	-	-	-	-	-	-	-	-
			G	101	-	-	-	-	-	-	-	-	-	-
			h	600	-	-	-	-	-	-	-	-	-	-
		Gear with handwheel	H1	221	424	260	362	424	430	540	570	747	762	786
G			101	188	135	179	188	216	295	326	420	438	465	
h1			48	60	48	70	60	45	50	50	60	60	60	
J			115	147	115	192	147	275	305	305	380	380	380	
ØW			280	320	280	400	320	400	500	500	500	500	500	
With ISO 5211 mounting pad		H2	178	376	226	304	376	352	443	470	637	650	695	
		G	101	188	135	179	188	216	295	326	420	438	465	
		h2	45	62	55	70	62	90	110	110	135	150	150	
		ISO	F12	F16	F12	F20	F16	F25	F30	F30	F35	F35	F35	
		Tr	30	40	32	45	40	60	75	75	90	115	115	
		Torque (Nm) (2)	339	1333	1201	1385	1333	3995	6274	9610	11336	18078	28165	
		Kvs-value	-	-	-	-	-	-	-	-	-	-	-	-
Approx. Weight RF (3)	72	189	125	207	189	480	815	1315	2090	3976	5560			
Approx. Weight BW	58	154	99	171	154	396	672	1070	1726	3465	4880			

(1) Other schedule nos. on request  
 (2) Torque includes 30% of safety factor  
 (3) RTJ weight increases approx. by 10%

Dimensions in mm (except for bolt holes - Ød -, which are in inch units) subject to manufacturing tolerance  
 Kvs-values in m³/h / Torques in Nm / Weights in kg  
 For more information about flanged and welded ends refer to page 16

Main Parts and Materials

SERIES BV B9 ANSI RANGE  
Class 2500 NPS2-4"

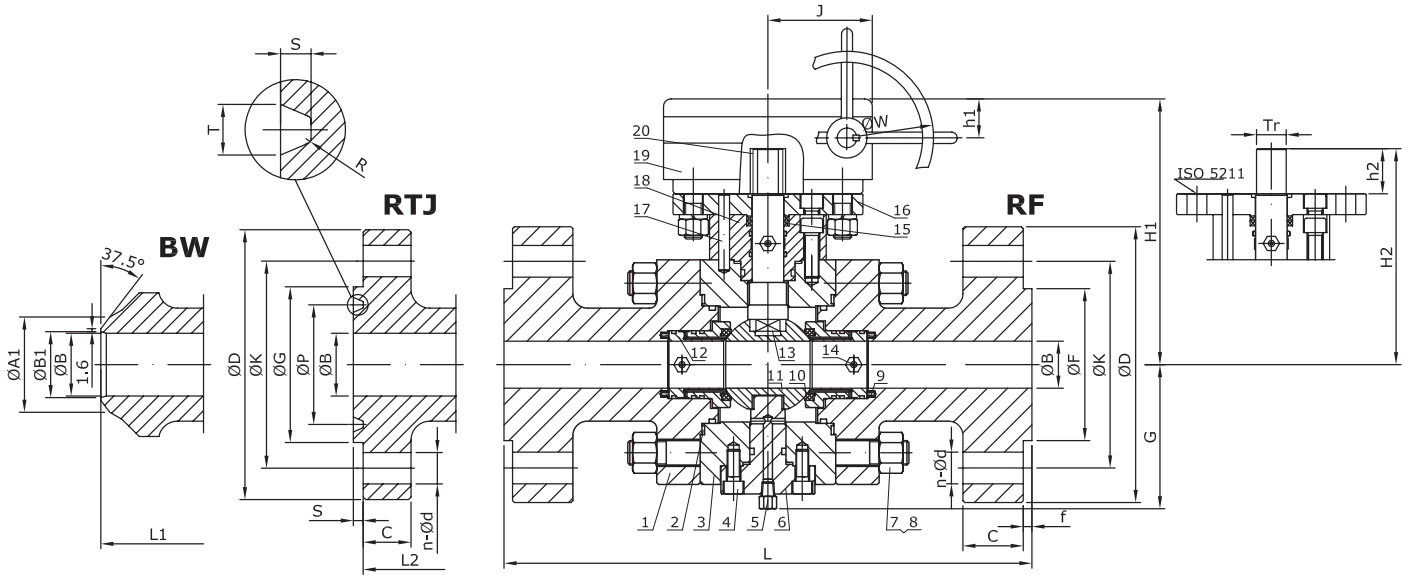

N°	Part name	A105 (B9A02_)	A105/NACE (B9A02_)	A350 LF2/ SS304 (B9A1_)	A350 LF2/ SS316 (B9A1_)	A182 F304 (B9I1_)	A182 F316 (B9I3_)	A182 F304L (B9I9_)	A182 F316 (B9J1_)
1	Body Cap	ASTM A105	ASTM A105N	A350 LF2		A182 F304	A182 F316	A182 F304L	A182 F316L
2	Body Gasket	SS304+ Graphite	SS316+ Graphite	SS304+ Graphite	SS316+ Graphite	SS304+ Graphite	SS316+ Graphite	SS304+ Graphite	SS316+ Graphite
3	Body	ASTM A105	ASTM A105N	A350 LF2		A182 F304	A182 F316	A182 F304L	A182 F316L
4	Screw	A193 B7	A193 B7M	A320 L7		A193 B8	A193 B8M	A193 B8M	
5	Drain Plug	AISI 1035	A182 F316	A182 F304	A182 F316	A182 F304	A182 F316	A182 F304L	A182 F316L
6	Bottom Cover	ASTM A105	ASTM A105N	A350 LF2		A182 F304	A182 F316	A182 F304L	A182 F316L
7	Body Bolt	A193 B7	A193 B7M	A320 L7		A193 B8	A193 B8M	A193 B8M	
8	Body Nut	A194 2H	A194 2HM	A194 4		A194 8	A194 8M	A194 8M	
9	Seat Spring	17-7PH		17-7PH		Inconel X-750		Inconel X-750	
10	Seat	DEVLON		DEVLON		PEEK		PEEK	
11	Ball	A105.ENP	A105N.ENP	A182 F304	A182 F316	A182 F304	A182 F316	A182 F304L	A182 F316L
12	Seat Retainer	ASTM A105	ASTM A105N	A350 LF2		A182 F304	A182 F316	A182 F304L	A182 F316L
13	Stem	A182 F6a	17-4PH	A182 F304	Nitronic 50	A182 F304	Nitronic 50	A182 F304L	Nitronic 50
14	Grease Injector	Assembly		Assembly		Assembly		Assembly	
15	Packing	Flexible Graphite		Flexible Graphite		PTFE		PTFE	
16	Gland Flange	ASTM A105	ASTM A105N	A350 LF2		A182 F304	A182 F316	A182 F304L	A182 F316L
17	Screw	A193 B7	A193 B7M	A320 L7		A193 B8	A193 B8M	A193 B8M	
18	Top cover	ASTM A105	ASTM A105N	A350 LF2		A182 F304	A182 F316	A182 F304L	A182 F316L
19	Worm Gear	Assembly		Assembly		Assembly		Assembly	
20	Key	AISI 1035		AISI 1035		A276 304		A276 304	

Main Parts and Materials

SERIES BV B9 ANSI RANGE  
Class 2500 NPS6-12"

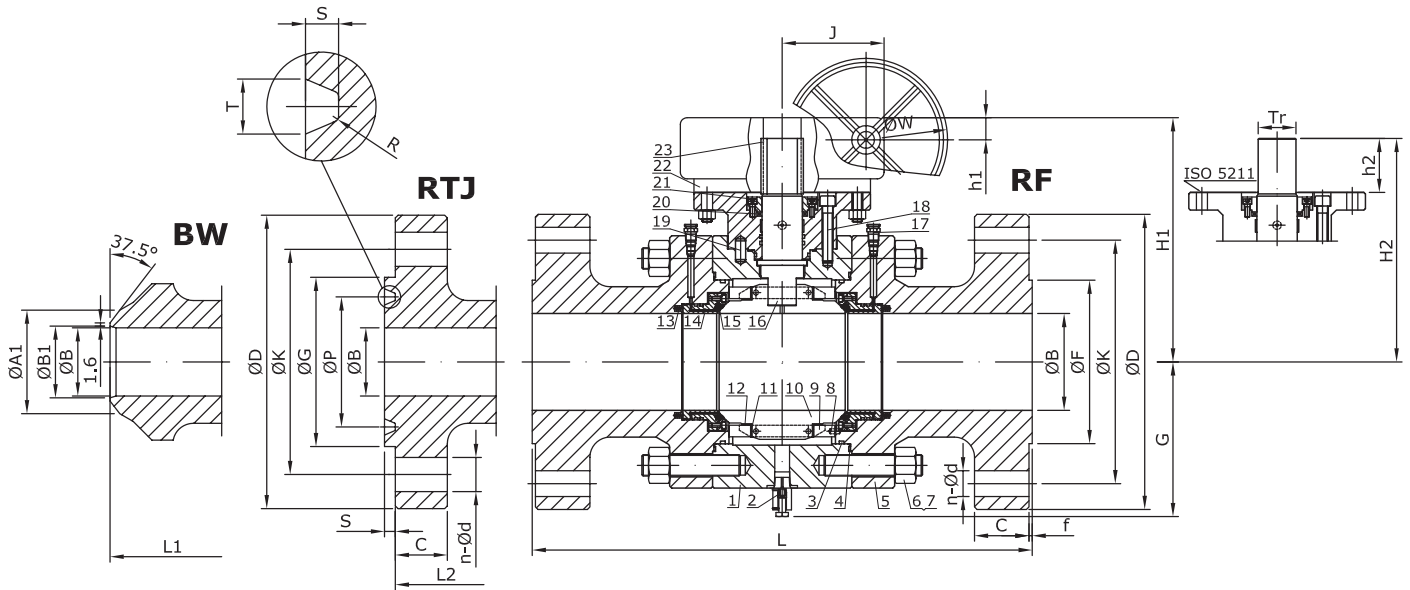

Nº	Part name	A105 (B9A02_)	A105/NACE (B9A02_)	A350 LF2/ SS304 (B9A1_)	A350 LF2/ SS316 (B9A1_)	A182 F304 (B911_)	A182 F316 (B913_)	A182 F304L (B919_)	A182 F316 (B9J1_)
1	Body	ASTM A105	ASTM A105N	A350 LF2		A182 F304	A182 F316	A182 F304L	A182 F316L
2	Drain Plug	AISI 1035	A182 F316	A182 F304	A182 F316	A182 F304	A182 F316	A182 F304L	A182 F316L
3	O Ring	VITON			VITON		VITON		VITON
4	Body Gasket	SS304+ Graphite	SS316+ Graphite	SS304+ Graphite	SS316+ Graphite	SS304+ Graphite	SS316+ Graphite	SS304+ Graphite	SS316+ Graphite
5	Body Cap	ASTM A105	ASTM A105N	A350 LF2		A182 F304	A182 F316	A182 F304L	A182 F316L
6	Body Bolt	A193 B7	A193 B7M	A320 L7		A193 B8	A193 B8M	A193 B8M	
7	Body Nut	A194 2H	A194 2HM	A194 4		A194 8	A194 8M	A194 8M	
8	Screw	A193 B7	A193 B7M	A320 L7		A193 B8	A193 B8M	A193 B8M	
9	Ball Supporter	ASTM A105	ASTM A105N	A350 LF2		A182 F304	A182 F316	A182 F304L	A182 F316L
10	Ball	A105.ENP	A105N.ENP	A182 F304	A182 F316	A182 F304	A182 F316	A182 F304L	A182 F316L
11	Slide Bearing	SS304+PTFE	SS316+PTFE	SS304+PTFE	SS316+PTFE	SS304+PTFE	SS316+PTFE	SS304+PTFE	SS316+PTFE
12	Thrust Bearing	SS304+PTFE	SS316+PTFE	SS304+PTFE	SS316+PTFE	SS304+PTFE	SS316+PTFE	SS304+PTFE	SS316+PTFE
13	Seat Spring	17-7PH		17-7PH		Inconel X-750		Inconel X-750	
14	Seat Retainer	ASTM A105	ASTM A105N	A350 LF2		A182 F304	A182 F316	A182 F304L	A182 F316L
15	Seat	DEVLON			DEVLON		PEEK		PEEK
16	Stem	A182 F6a	17-4PH	A182 F304	Nitronic 50	A182 F304	Nitronic 50	A182 F304L	Nitronic 50
17	Grease Injector	Assembly			Assembly		Assembly		Assembly
18	Screw	A193 B7	A193 B7M	A320 L7		A193 B8	A193 B8M	A193 B8M	
19	Screw	A193 B7	A193 B7M	A320 L7		A193 B8	A193 B8M	A193 B8M	
20	Packing	Flexible Graphite			Flexible Graphite		PTFE		PTFE
21	Gland Flange	ASTM A105	ASTM A105N	A350 LF2		A182 F304	A182 F316	A182 F304L	A182 F316L
22	Worm Gear	Assembly			Assembly		Assembly		Assembly
23	Key	AISI 1035			AISI 1035		A276 304		A276 304

Main Valve Parameters - Class 2500

SERIES BV B9 ANSI RANGE

Nominal Size		inch	2"	2-1/2"	3"	4"	5"	6"	8"	10"	12"	
DN			50	65	80	100	125	150	200	250	300	
End connection	RF	L	451	508	578	673		914	1022	1270	1422	
		ØB	38	48,925	57	73	92,95	111	146	184	219	
		ØD	235	265	305	355	420	485	550	675	760	
		ØK	171,4	196,8	228,6	273	323,8	368,3	438,2	539,8	619,1	
		ØF	92,1	104,8	127	157,2	185,7	215,9	269,9	323,8	381	
		C	50,9	57,2	66,7	76,2	92,1	108	127	165,1	184,2	
		f	7	7	7	7	7	7	7	7	7	
	n-Ød	8 - 1 1/8	8 - 1 1/4	8 - 1 3/8	8 - 1 5/8	8 - 1 7/8	8 - 2 1/8	12 - 2 1/8	12 - 2 5/8	12 - 2 7/8		
	BW	L1	451	508	578	673		914	1022	1270	1422	
		Schedule No.(1)	160	-	160	160	-	160	160	160	160	
		ØB	38	48,925	57	73	92,95	111	146	184	219	
		ØA1	60,3	-	91	117	-	172	223	278	329	
		ØB1	42,82	-	66,5	87,5	-	132	173	216	257	
	RTJ	L2	454	514	584	683	13	927	1038	1292	1444	
		ØB	38	48,925	57	73	92,95	111	146	184	219	
		ØD	235	265	305	355	420	485	550	675	760	
		ØK	171,4	196,8	228,6	273	323,8	368,3	438,2	539,8	619,1	
		ØG	133	149	168	203	241	279	340	425	495	
		ØP	101,6	111,13	127	157,18	190,5	228,6	279,4	342,9	406,4	
		C	50,9	57,2	66,7	76,2	92,1	108	127	165,1	184,2	
		n-Ød	8 - 1 1/8	8 - 1 1/4	8 - 1 3/8	8 - 1 5/8	8 - 1 7/8	8 - 2 1/8	12 - 2 1/8	12 - 2 5/8	12 - 2 7/8	
		T	11,91	13,49	13,49	16,66	19,84	19,84	23,01	30,18	33,32	
		S	7,92	9,53	9,53	11,13	12,7	12,7	14,27	17,48	17,48	
		R	0,8	1,5	1,5	1,5	1,5	1,5	1,5	2,4	2,4	
	Top works/Operation	Lever	H	-	-	-	-	-	-	-	-	-
			G	-	-	-	-	-	-	-	-	-
			h	-	-	-	-	-	-	-	-	-
		Gear with handwheel	H1	288	424	330	497	424	591	667	765	780
G			121	188	152	205	188	301	390	425	445	
h1			68	60	70	45	60	45	50	60	60	
J			170	147	192	275	147	275	305	380	380	
ØW			350	320	400	400	320	400	500	500	500	
With ISO 5211 mounting pad		H2	214	376	260	408	376	517	585	665	685	
		G	121	188	152	205	188	301	390	425	445	
		h2	50	62	60	110	62	125	140	150	150	
		ISO	F16	F16	F20	F25	F16	F25	F30	F35	F35	
		Tr	34	40	43	70	40	85	90	110	120	
		Torque (Nm) (2)	538	1333	1955	2242	1333	6579	10725	15874	18658	
	Kvs-value	-	-	-	-	-	-	-	-	-		
Approx. Weight RF (3)	102	189	206	298	189	785	1375	2190	3320			
Approx. Weight BW	79	154	154	219	154	579	1344	1608	2490			

(1) Other schedule nos. on request  
 (2) Torque includes 30% of safety factor  
 (3) RTJ weight increases approx. by 10%

Dimensions in mm (except for bolt holes - Ød -, which are in inch units) subject to manufacturing tolerance  
 Kvs-values in m³/h / Torques in Nm / Weights in kg  
 For more information about flanged and welded ends refer to page 16