

GEMÜ 549 eSyDrive

Motorized angle seat globe valve



Features

- CIP/SIP capable
- Linear or modified equal-percentage control characteristics
- Open/close function, positioner and process controller
- Force and speed are variably adjustable
- Actuating speed max. 6 mm/s
- Extensive diagnostic functions
- Operable via web interface eSy-Web or Modbus TCP
- On-site or remote end position programming via programming input
- Various functions integrated (e.g. feedback, stroke limiter, etc.)

Description

The GEMÜ 549 eSyDrive is a motorized 2/2-way angle seat globe valve with a hollow shaft electric actuator. The eSyDrive hollow shaft actuator can be operated as ON/OFF or with integrated positioner or process controller. The valve spindle is sealed by a self-adjusting gland packing providing low maintenance and reliable valve spindle sealing even after a long service life. A wiper ring fitted in front of the gland packing protects the seal against contamination and damage. An integral optical and electrical position indicator is standard.

Technical specifications

- **Media temperature:** -10 to 180 °C
- **Ambient temperature:** -10 to 60 °C
- **Operating pressure:** 0 to 25 bar
- **Nominal sizes:** DN 10 to 80
- **Body configurations:** 2/2-way body | Angle valve body
- **Connection types:** Clamp | Flange | Spigot | Threaded connection
- **Connection standards:** ANSI | ASME | BS | DIN | EN | ISO | NPT | SMS
- **Body materials:** 1.4408, investment casting material | 1.4435 (316L), forged material | 1.4435, investment casting material
- **Seat seal materials:** 1.4404 | PTFE | PTFE, reinforced
- **Supply voltage:** 24 V DC
- **Actuating speed:** max. 6 mm/s
- **Protection class:** IP 65, IP 61
- **Conformities:** FDA | Oxygen | Reg. (EU) No. 10/2011 | Regulation (EC) No. 1935/2004

Technical data depends on the respective configuration



Product description

Construction

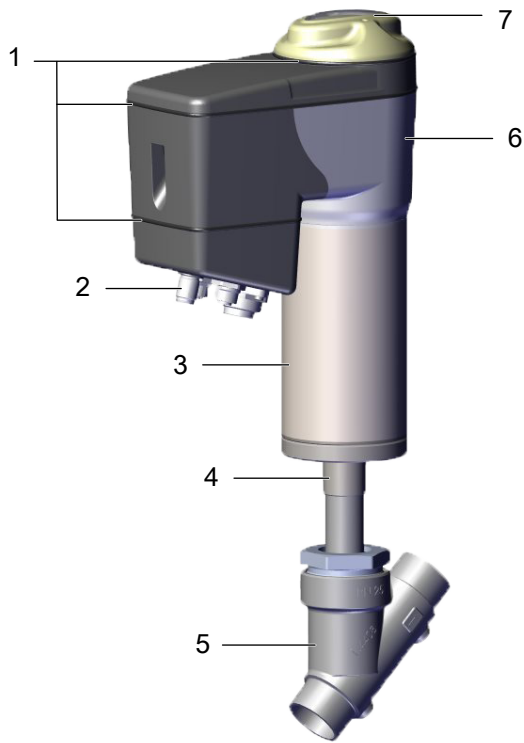

Item	Name	Materials
1	O-rings	EPDM
2	Electrical connections	
3	Actuator base	1.4301
4	Distance piece with leak detection hole	1.4408
5	Valve body	1.4408, 1.4435
6	Optical position indicator	PESU
7	Cover with high visibility LED, manual override and on-site control	PESU

GEMÜ CONEXO

The interaction of valve components that are equipped with RFID chips and an associated IT infrastructure actively increase process reliability.



Thanks to serialization, every valve and every relevant valve component such as the body, actuator or diaphragm, and even automation components, can be clearly traced and read using the CONEXO pen RFID reader. The CONEXO app, which can be installed on mobile devices, not only facilitates and improves the "installation qualification" process, but also makes the maintenance process much more transparent and easier to document. The app actively guides the maintenance technician through the maintenance schedule and directly provides him with all the information assigned to the valve, such as test reports, testing documentation and maintenance histories. The CONEXO portal acts as a central element, helping to collect, manage and process all data.

For further information on GEMÜ CONEXO please visit:

www.gemu-group.com/conexo

Ordering

GEMÜ Conexo must be ordered separately with the ordering option "CONEXO" (see order data).

In the corresponding design with CONEXO, this product has an RFID chip (1) for electronic identification purposes. The position of the RFID chip can be seen below. The CONEXO pen helps read out information stored in the RFID chips. The CONEXO app or CONEXO portal is required to view this information.

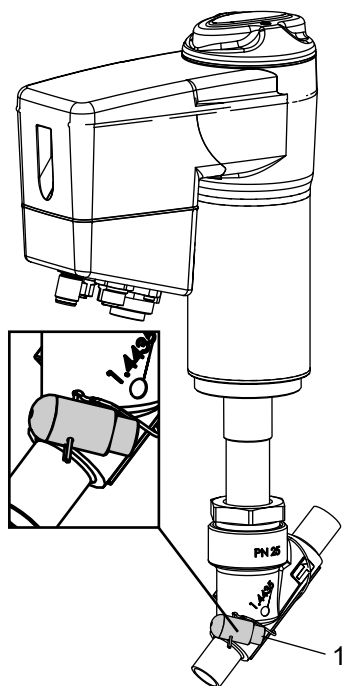

Kv value diagram

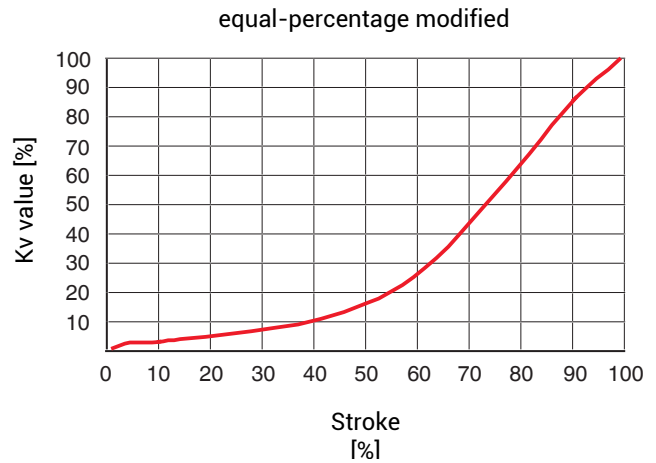
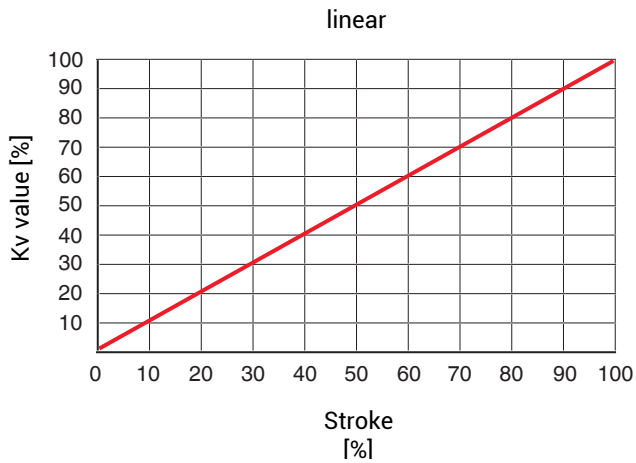

The diagram shows the approximative curve of the Kv value characteristic. The characteristic may deviate depending on valve body, nominal size, regulating cone and valve stroke.

Regulating cone/regulating cage

Regulating needle	Regulating cone	Regulating cage
Regulating needle: RAxxx – RCxxx (reduced valve seat)	Regulating cone: DN 15 - 50	Regulating cage: DN 65 – 100

Availability

Availability of valve bodies

Spigot

DN	Connection types code ¹⁾																
	0	16	17			18	37			59			60			63	65
	Material code ²⁾																
	34	34	34	37	C2	34	34	37	34	37	C2	34	37	C2	37	34	
10	-	X	X	-	X	-	-	-	-	-	-	X	-	X	-	-	
15	X	X	X	X	X	X	-	-	X	-	X	X	X	X	X	X	
20	X	X	X	X	X	X	-	-	X	-	X	X	X	X	X	X	
25	X	X	X	X	X	X	X	-	X	-	X	X	X	X	X	X	
32	X	X	X	X	X	X	-	-	-	-	-	X	X	X	-	X	
40	X	X	X	X	X	X	X	-	X	-	X	X	X	X	X	X	
50	X	X	X	X	X	X	X	-	X	-	X	X	X	X	X	X	
65	-	-	-	X	X	-	-	X	-	X	X	-	X	X	X	-	
80	-	-	-	X	X	-	-	X	-	X	X	-	X	X	X	-	

X = Standard

1) Connection type

Code 0: Spigot DIN

Code 16: Spigot EN 10357 series B, formerly DIN 11850 series 1

Code 17: Spigot EN 10357 series A (formerly DIN 11850 series 2)/DIN 11866 series A

Code 18: Spigot DIN 11850 series 3

Code 37: Spigot SMS 3008

Code 59: Spigot ASME BPE

Code 60: Spigot ISO 1127/EN 10357 series C/DIN 11866 series B

Code 63: Spigot ANSI/ASME B36.19M schedule 10s

Code 65: Spigot ANSI/ASME B36.19M schedule 40s

2) Valve body material

Code 34: 1.4435, investment casting

Code 37: 1.4408, investment casting

Code C2: 1.4435, investment casting

Threaded connection

DN	2/2-way body				Angle valve body	
	Connection types code ¹⁾					
	1	3C	3D	9	1	3D
	Material code 37 ²⁾					
10	X	-	-	-	-	-
15	X	X	X	X	X	X
20	X	X	X	X	X	X
25	X	X	X	X	X	X
32	X	X	X	X	X	X
40	X	X	X	X	X	X
50	X	X	X	X	X	X
65	X	X	X	X	-	-
80	X	X	X	X	-	-

X = Standard

1) Connection type

Code 1: Threaded socket DIN ISO 228

Code 3C: Threaded socket Rc ISO 7-1, EN 10226-1, JIS B 0203, BS 21, end-to-end dimension ETE DIN 3202-4 series M8

Code 3D: Threaded socket NPT, end-to-end dimension ETE DIN 3202-4 series M8

Code 9: Threaded spigot DIN ISO 228

2) Valve body material

Code 37: 1.4408, investment casting

Flange

DN	Connection types code ¹⁾		
	10	13	47
	Material code ²⁾		
	37	34	34
15	X	X	X
20	X	X	X
25	X	X	X
32	X	X	X
40	X	X	X
50	X	X	X

X = Standard

1) **Connection type**

Code 10: Flange EN 1092, PN 25, form B, face-to-face dimension FTF EN 558 series 1, ISO 5752, basic series 1

Code 13: Flange EN 1092, PN 25, form B

Code 47: Flange ANSI Class 150 RF

2) **Valve body material**

Code 34: 1.4435, investment casting

Code 37: 1.4408, investment casting

Clamp

DN	Connection types code ¹⁾						
	80	82	86	88	80	82	86
	Material code ²⁾						
	34	34	C2	34	C2	34	C2
15	X	X	X	X	X	X	X
20	X	X	X	X	X	X	X
25	X	X	X	X	X	X	X
32	-	X	X	X	X	-	-
40	X	X	X	X	X	X	X
50	X	X	X	X	X	X	X
65	-	-	X	-	X	-	X
80	-	-	X	-	X	-	X

X = Standard

1) **Connection type**

Code 80: Clamp ASME BPE, face-to-face dimension FTF ASME BPE

Code 82: Clamp DIN 32676 series B, face-to-face dimension FTF EN 558 series 1

Code 86: Clamp DIN 32676 series A, face-to-face dimension FTF EN 558 series 1

Code 88: Clamp ASME BPE, face-to-face dimension FTF EN 558 series 1

2) **Valve body material**

Code 34: 1.4435, investment casting

Code C2: 1.4435, investment casting

Order data

The order data provide an overview of standard configurations.

Please check the availability before ordering. Other configurations available on request.

Order codes

1 Type	Code
Angle seat globe valve, motorized, electro-mechanical hollow shaft actuator, eSyDrive	549

2 DN	Code
DN 10	10
DN 15	15
DN 20	20
DN 25	25
DN 32	32
DN 40	40
DN 50	50
DN 65	65
DN 80	80

3 Body configuration	Code
2/2-way body	D
Angle valve body	E

4 Connection type	Code
Spigot	
Spigot DIN	0
Spigot EN 10357 series B, formerly DIN 11850 series 1	16
Spigot EN 10357 series A (formerly DIN 11850 series 2)/DIN 11866 series A	17
Spigot DIN 11850 series 3	18
Spigot SMS 3008	37
Spigot ASME BPE	59
Spigot ISO 1127/EN 10357 series C/DIN 11866 series B	60
Spigot ANSI/ASME B36.19M schedule 10s	63
Spigot ANSI/ASME B36.19M schedule 40s	65
Threaded connection	
Threaded socket DIN ISO 228	1
Threaded socket Rc ISO 7-1, EN 10226-1, JIS B 0203, BS 21, end-to-end dimension ETE DIN 3202-4 series M8	3C
Threaded socket NPT, end-to-end dimension ETE DIN 3202-4 series M8	3D
Threaded spigot DIN ISO 228	9
Flange	
Flange EN 1092, PN 25, form B, face-to-face dimension FTF EN 558 series 1, ISO 5752, basic series 1	10
Flange EN 1092, PN 25, form B	13
Flange ANSI Class 150 RF	47

4 Continuation of Connection type	Code
Clamp	
Clamp ASME BPE, face-to-face dimension FTF ASME BPE	80
Clamp DIN 32676 series B, face-to-face dimension FTF EN 558 series 1	82
Clamp DIN 32676 series A, face-to-face dimension FTF EN 558 series 1	86
Clamp ASME BPE, face-to-face dimension FTF EN 558 series 1	88

5 Valve body material	Code
1.4435, investment casting	34
1.4408, investment casting	37
1.4435 (F316L), forged body	40
1.4435, investment casting	C2

6 Seat seal	Code
PTFE	5
PTFE, glass fibre reinforced	5G
1.4404	10

7 Voltage/frequency	Code
24 V DC	C1

8 Control module	Code
OPEN/CLOSE, positioner and process controller	L0

9 Regulating cone	Code
Please find the number of the optional regulating cone (R-No.) for the linear or equal-percentage modified regulating cone in the Kv value table.	R...

10 Actuator version	Code
Actuator size 0	0A
Actuator size 1	1A
Actuator size 2	2 A

11 Type of design	Code
Ra ≤ 0.6 μm (25 μinch) for media wetted surfaces, in accordance with ASME BPE SF2 + SF3 mechanically polished internal	1903
Ra ≤ 0.8 μm (30 μinch) for media wetted surfaces, in accordance with DIN 11866 H3, mechanically polished internal	1904
Ra ≤ 0.4 μm (15 μinch) for media wetted surfaces, in accordance with DIN 11866 H4, ASME BPE SF1 mechanically polished internal	1909

12 Special version	Code
Special version for oxygen, maximum medium temperature: 60 °C, media wetted seal materials and auxiliary materials with BAM testing	S

Order data

13 CONEXO	Code	13 Continuation of CONEXO	Code
without		Integrated RFID chip for electronic identification and traceability	C

Order example

Order option	Code	Description
1 Type	549	Angle seat globe valve, motorized, electro-mechanical hollow shaft actuator, eSyDrive
2 DN	50	DN 50
3 Body configuration	D	2/2-way body
4 Connection type	1	Threaded socket DIN ISO 228
5 Valve body material	37	1.4408, investment casting
6 Seat seal	5	PTFE
7 Voltage/frequency	C1	24 V DC
8 Control module	L0	OPEN/CLOSE, positioner and process controller
9 Regulating cone	RS916	60 m ³ /h - mod.EQ
10 Actuator version	2 A	Actuator size 2
11 Type of design		
12 Special version	S	Special version for oxygen, maximum medium temperature: 60 °C, media wetted seal materials and auxiliary materials with BAM testing
13 CONEXO		without

Technical data

Medium

Working medium: Corrosive, inert, gaseous and liquid media which have no negative impact on the physical and chemical properties of the body and seal material.

Max. permissible viscosity: 600 mm²/s (cSt)
Other versions for lower/higher temperatures and higher viscosities on request.

Temperature

Media temperature: -10 to 180 °C

Ambient temperature: -10 to 60 °C

Pressure

Operating pressure:

DN	Actuator version 0A	Actuator version 1A	Actuator version 2A
10	0 - 25	-	-
15	0 - 25	-	-
20	0 - 20	0 - 25	-
25	0 - 12	0 - 25	-
32	-	0 - 20	-
40	-	0 - 12	0 - 25
50	-	0 - 8	0 - 16
65	-	0 - 5	0 - 10
80	-	0 - 4	0 - 6

Pressures in bar
All pressures are gauge pressures.
For max. operating pressures the pressure / temperature correlation must be observed.
Higher operating pressures on request

Leakage rate:

Open/Close valve

Seat seal	Standard	Test procedure	Leakage rate	Test medium
Metal	DIN EN 12266-1	P12	F	Air
EPDM, FKM, PTFE	DIN EN 12266-1	P12	A	Air

Control valve

Seat seal	Standard	Test procedure	Leakage rate	Test medium
Metal	DIN EN 60534-4	1	IV	Air
PTFE, FKM, EPDM	DIN EN 60534-4	1	VI	Air

Pressure/temperature correlation:

Connection types code ¹⁾	Material code ²⁾	Max. allowable operating pressures in bar at temperature in °C					
		RT	100	150	200	250	300
1, 9, 17, 37, 60, 63, 3C, 3D	37	25.0	23.8	21.4	18.9	17.5	16.1
0, 16, 17, 18, 37, 59, 60, 65	34	25.0	24.5	22.4	20.3	18.2	16.1
13 (DN 15 - DN 50)	34	25.0	23.6	21.5	19.8	18.6	17.2
80, 88 (DN 15 - DN 40)	34	25.0	21.2	19.3*	-	-	-
80, 88 (DN 50 - DN 80)	34	16.0	16.0	16.0*	-	-	-
82 (DN 15 - DN 32)	34	25.0	21.2	19.3*	-	-	-
82 (DN 40 - DN 65)	34	16.0	16.0	16.0*	-	-	-
86 (DN 15 - DN 40)	34	25.0	21.2	19.3*	-	-	-
86 (DN 50 - DN 65)	34	16.0	16.0	16.0*	-	-	-
10 (DN 15 - DN 50)	37	25.0	25.0	22.7	21.0	19.8	18.5
47 (DN 15 - DN 50)	34	15.9	13.3	12.0	11.1	10.2	9.7
0, 16, 17, 18, 59, 60	40	25.0	20.6	18.7	17.1	15.8	14.8
17, 59, 60	C2	25.0	21.2	19.3	17.9	16.8	15.9

* max. temperature 140 °C

1) **Connection type**

- Code 0: Spigot DIN
- Code 1: Threaded socket DIN ISO 228
- Code 3C: Threaded socket Rc ISO 7-1, EN 10226-1, JIS B 0203, BS 21, end-to-end dimension ETE DIN 3202-4 series M8
- Code 3D: Threaded socket NPT, end-to-end dimension ETE DIN 3202-4 series M8
- Code 9: Threaded spigot DIN ISO 228
- Code 10: Flange EN 1092, PN 25, form B, face-to-face dimension FTF EN 558 series 1, ISO 5752, basic series 1
- Code 13: Flange EN 1092, PN 25, form B
- Code 16: Spigot EN 10357 series B, formerly DIN 11850 series 1
- Code 17: Spigot EN 10357 series A (formerly DIN 11850 series 2)/DIN 11866 series A
- Code 18: Spigot DIN 11850 series 3
- Code 37: Spigot SMS 3008
- Code 47: Flange ANSI Class 150 RF
- Code 59: Spigot ASME BPE
- Code 60: Spigot ISO 1127/EN 10357 series C/DIN 11866 series B
- Code 63: Spigot ANSI/ASME B36.19M schedule 10s
- Code 65: Spigot ANSI/ASME B36.19M schedule 40s
- Code 80: Clamp ASME BPE, face-to-face dimension FTF ASME BPE
- Code 82: Clamp DIN 32676 series B, face-to-face dimension FTF EN 558 series 1
- Code 86: Clamp DIN 32676 series A, face-to-face dimension FTF EN 558 series 1
- Code 88: Clamp ASME BPE, face-to-face dimension FTF EN 558 series 1

2) **Valve body material**

- Code 34: 1.4435, investment casting
- Code 37: 1.4408, investment casting
- Code 40: 1.4435 (F316L), forged body
- Code C2: 1.4435, investment casting

Kv values:

Open/Close valve

	Butt weld spigot DIN 11850	Butt weld spigot DIN 11866	Threaded socket DIN ISO 228
DN			
10	-	-	-
15	2.4	5.5	5.4
20	-	11.7	10.0
25	-	20.5	15.2
32	-	33.0	23.0
40	-	51.0	41.0
50	-	61.0	68.0
65	-	110.0	95.0
80	-	117.0	130.0

Kv values determined in accordance with DIN EN 60534. The Kv value specifications refer to the largest actuator for the respective nominal size. The Kv values for other product configurations (e.g. other connections or body materials) may differ.
Kv values in m³/h

Control valve:

Standard regulating cone (DIN)

DN	Kv values	Operating pressure	Actuator version	linear	equal percentage
15	5.0	32.0	0A	RS920	RS930
20	10.0	20.0	0A	RS921	RS931
25	15.0	12.0	0A	RS922	RS932
	15.0	32.0	1A	RS923	RS933
32	24.0	20.0	1A	RS924	RS934
40	38.0	12.0	1A	RS925	RS935
	38.0	20.0	2 A	RS905	RS915
50	50.0	8.0	1A	RS926	RS936
	60.0	20.0	2 A	RS906	RS916
65	60.0	5.0	1A	-	RS937
	60.0	15.0	2 A	-	RS917
80	80.0	4.0	1A	-	RS938
	80.0	6.0	2 A	-	RS918

Kv values in m³/h

Standard regulating cone (ANSI)

DN	Kv values	Operating pressure	Actuator version	linear	equal percentage
15	2.7	32.0	0A	RS961	RS971
20	6.3	20.0	0A	RS962	RS972
25	13.3	12.0	0A	RS963	RS973
	13.3	32.0	1A	RS964	RS974
40	35.6	12.0	1A	RS965	RS975
	35.6	20.0	2 A	RS945	RS955
50	50.0	8.0	1A	RS966	RS976
	58.0	20.0	2 A	RS946	RS956
65	60.0	5.0	1A	-	RS977
	60.0	15.0	2 A	-	RS957
80	80.0	4.0	1A	-	RS978
	80.0	6.0	2 A	-	RS958

Kv values in m³/h

Control valve:

Standard regulating cone with reduced seat

DN	Kv values	Operating pressure	Actuator version	linear	equal percentage
15	0.10 ¹⁾	25.0	0A	RA204	RA407
	0.16 ¹⁾	25.0	0A	RB210	RA408
	0.25 ¹⁾	25.0	0A	RB211	RB407
	0.40 ¹⁾	25.0	0A	RB212	RB408
	0.63 ¹⁾	25.0	0A	RC207	RC408
	1.00 ¹⁾	25.0	0A	RC208	RC409
	1.60	25.0	0A	RD209	RD409
	2.50 ²⁾	25.0	0A	RE210	RE410
20	1.60	25.0	0A	RD210	RD410
	2.50	25.0	0A	RE211	RE411
	4.00	25.0	0A	RF212	RF412
	6.30 ²⁾	25.0	0A	RG213	RG413
25	2.50	25.0	0A	RE212	RE412
	4.00	25.0	0A	RF213	RF413
	6.30	25.0	0A	RG214	RG414
	10.0 ²⁾	18.0	0A	RH213	RH413
32	4.00	25.0	0A	RF214	RF414
	6.30	25.0	0A	RG215	RG415
	10.00	20.0	0A	RH214	RH414
	16.00	12.0	0A	RJ210	RJ410
40	6.30	25.0	0A	RG216	RG416
	10.00	20.0	0A	RH215	RH415
	16.00	12.0	0A	RJ211	RJ411
	25.00	18.0	1A	RK207	RK407
50	10.00	18.0	0A	RH216	RH416
	16.00	12.0	0A	RJ212	RJ412
	25.00	19.0	1A	RK208	RK408
	40.00	12.0	1A	RM204	RM404

1) metal seated

2) not for connection codes 37, 59, 80, 88

Kv values in m³/h

Product compliance

Food: Regulation (EC) No. 1935/2004*
 Regulation (EC) No. 10/2011*
 FDA*
 * depending on version and/or operating parameters

Pressure Equipment Directive: 2014/68/EU

Machinery Directive: 2006/42/EU

Mechanical data

Protection class: IP 65 acc. to EN 60529 Actuator version 0A, 2A
 IP 61 acc. to EN 60529 Actuator version 1A

Weight: **Actuator**
 Actuator version 0A 1.8 kg
 Actuator version 1A 3.0 kg
 Actuator version 2A 9.0 kg

Body

Connection types	0, 16, 17, 18, 37, 59, 60, 63, 65	1, 31, 3B	9	10, 13, 47	80, 82, 86, 88
Valve body	Spigot K514	Threaded socket	Threaded spigot	Flange K514	Clamp
DN					
15	0.24	0.35	0.31	1.80	0.37
20	0.50	0.35	0.50	2.50	0.63
25	0.50	0.35	0.65	3.10	0.63
32	0.90	0.75	1.00	4.60	1.08
40	1.10	0.98	1.30	5.10	1.28
50	1.80	1.70	1.80	7.20	2.07
65	3.40	3.20	3.40	-	3.69
80	4.20	4.10	4.40	-	4.60

Weights in kg

Operating time: Actuator version 0A 6 mm/s
 Actuator version 1A 6 mm/s
 Actuator version 2A 4 mm/s

Electrical data

Supply voltage:

	Actuator size 0	Actuator size 1	Actuator size 2
Voltage	U _v = 24 V DC ± 10%		
Rating	Max. 28 W	Max. 65 W	Max. 120 W
Operating mode (OPEN/CLOSE operation)	Continuous duty		
Operating mode (control operation)	Class C acc. to EN 15714-2		
Reverse battery protection	Yes		

Analogue input signals

Set value

Input signal:	0/4 - 20 mA; 0 – 10 V DC (selectable using software)
Input type:	passive
Input resistance:	250 Ω
Accuracy/linearity:	≤ ±0.3% of full flow
Temperature drift:	≤ ±0.1% / 10°K
Resolution:	12 bit
Reverse battery protection:	No
Overload proof:	Yes (up to ± 24 V DC)

Process actual value

Input signal:	0/4 - 20 mA; 0 – 10 V DC (selectable using software)
Input type:	passive
Input resistance:	250 Ω
Accuracy/linearity:	≤ ±0.3% of full flow
Temperature drift:	≤ ±0.1% / 10°K
Resolution:	12 bit
Reverse battery protection:	No
Overload proof:	Yes (up to ± 24 V DC)

Digital input signals

Digital inputs:	3
Function:	selectable using software
Voltage:	24 V DC
Logic level "1":	>14 V DC
Logic level "0":	< 8 V DC
Input current:	typ. 2.5 mA (at 24 V DC)

Analogue output signals

Actual value

Output signal:	0/4 - 20 mA; 0 - 10 V DC (selectable using software)
Output type:	Active (AD5412)
Accuracy:	$\leq \pm 1\%$ of full flow
Temperature drift:	$\leq \pm 0.1\% / 10^\circ\text{K}$
Load resistor:	$\leq 750 \text{ k}\Omega$
Resolution:	10 bit
Overload proof:	Yes (up to $\pm 24 \text{ V DC}$)
Short-circuit proof:	Yes

Digital output signals

Switching outputs 1 and 2

Design:	2x change-over contact, potential-free
Switch rating:	125 V AC / 2 A 48 V DC / 2 A
Switch points:	Adjustable 0 - 100 %

Switching output 3

Function:	Signal fault
Type of contact:	Push-Pull
Switching voltage:	Supply voltage
Switching current:	$\leq 0.1 \text{ A}$
Drop voltage:	Max. 2.5 V DC at 0.1 A
Overload proof:	Yes (up to $\pm 24 \text{ V DC}$)
Short-circuit proof:	Yes
Pull-Down resistance:	120 k Ω

Communication

Interface:	Ethernet
------------	----------

Technical data

Function:	Parameterisation via web browser
IP address:	192.168.2.1 alterable via web browser
Subnet screen:	255.255.252.0 alterable via web browser

The actuator and the PC must be in the same network to use the web server. The IP address of the actuator is entered in the web browser and the actuator can then be parametrised. In order to use more than one actuator, a definitive IP address must be assigned to each actuator in the same network.

Electrical connections

NOTICE

Appropriate cable socket/appropriate mating connector!

The appropriate cable socket and/or appropriate mating connector is included for X1, X3 and X4.

The appropriate cable socket and/or appropriate mating connector is **not** included for X2.

Connection X1

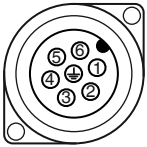

7-pin plug, Binder, type 693

Pin	Signal name
Pin 1	Uv, 24 V DC supply voltage
Pin 2	Uv GND
Pin 3	Relay output K1, common
Pin 4	Relay output K1, make contact
Pin 5	Relay output K2, common
Pin 6	Relay output K2, make contact
Pin PE	Function earth

Connection X2



5-pin M12 built-in socket, D-coded

Pin	Signal name
Pin 1	Tx + (Ethernet)
Pin 2	Rx + (Ethernet)
Pin 3	Tx - (Ethernet)
Pin 4	Rx - (Ethernet)
Pin 5	Shield

Connection X3

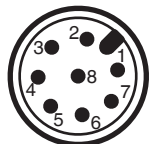

8-pin M12 plug, A-coded

Pin	Signal name
Pin 1	I + set value input
Pin 2	I – set value input
Pin 3	I + actual value output
Pin 4	GND (actual value output, digital input 1 – 3, error message output)
Pin 5	Error message output 24 V DC
Pin 6	Digital input 3
Pin 7	Digital input 1
Pin 8	Digital input 2

Connection X4



4-pin M12 built-in socket, A-coded

Pin	Signal name
Pin 1	UV, 24 V DC actual value supply
Pin 2	n.c.
Pin 3	GND (actual value supply, actual value input)
Pin 4	X+, process actual value input
Pin 5	n.c.

Dimensions

Installation dimensions - Valve with 2/2-way body

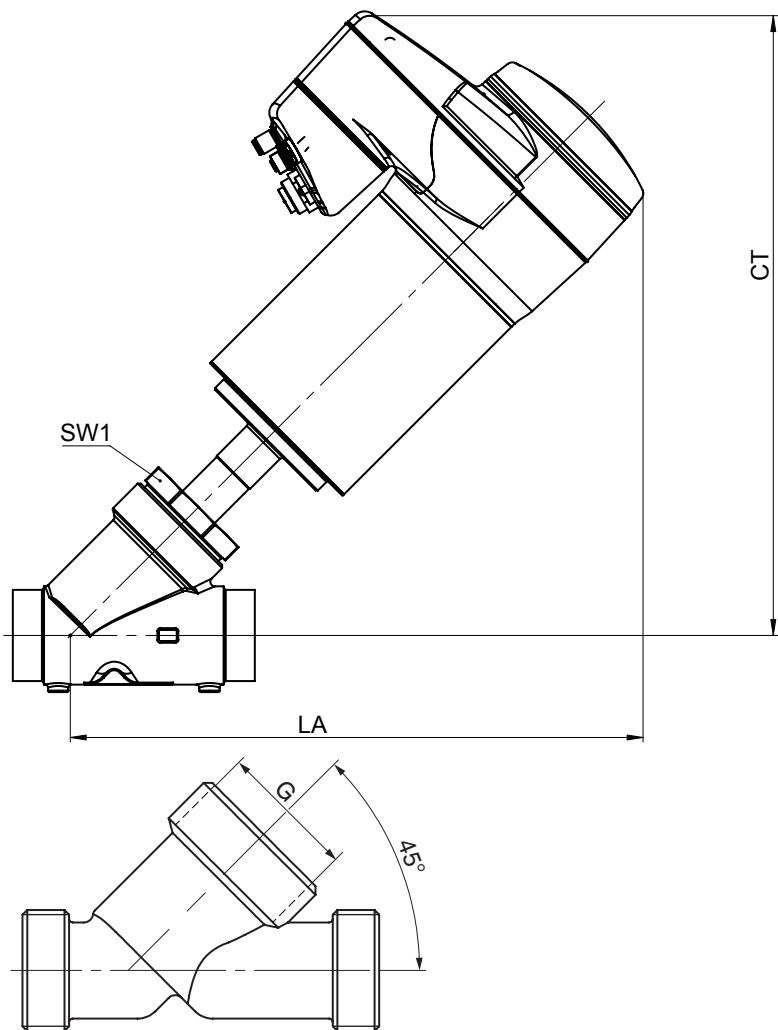

DN	SW1	G	Actuator version 0A		Actuator version 1A		Actuator version 2A	
			CT	LA	CT	LA	CT	LA
10	36	-	287.0	242.0	-	-	-	-
15	36	M 34x1.5	290.0	245.0	-	-	-	-
20	41	M 40x1.5	300.0	255.0	341.0	299.0	-	-
25	46	M 45x1.5	300.0	255.0	341.0	299.0	-	-
32	55	M 52x1.5	-	-	349.0	307.0	402.0	368.0
40	60	M 60x2.0	-	-	354.0	312.0	407.0	373.0
50	75	M 72x2.0	-	-	362.0	320.0	405.0	381.0
65	75	M 90x2.0	-	-	375.0	333.0	428.0	394.0
80	75	M 105x2.0	-	-	-	-	445.0	411.0

Dimensions in mm

Installation dimensions - Valve with angle valve body

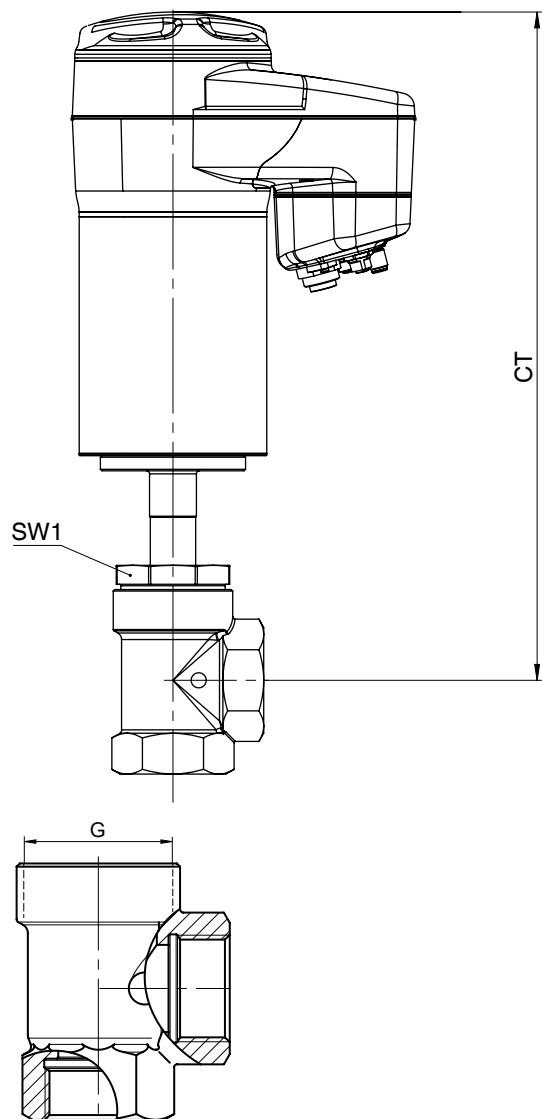

DN	SW1	R	Actuator version 0A	Actuator version 1A	Actuator version 2A
			CT	CT	CT
15	36	G ½	293.0	-	-
20	41	G ¾	296.0	353.0	-
25	46	G 1	300.0	357.0	-
32	55	-	-	360.0	429.0
40	60	-	-	365.0	434.0
50	75	-	-	372.0	441.0

Dimensions in mm

Actuator dimensions

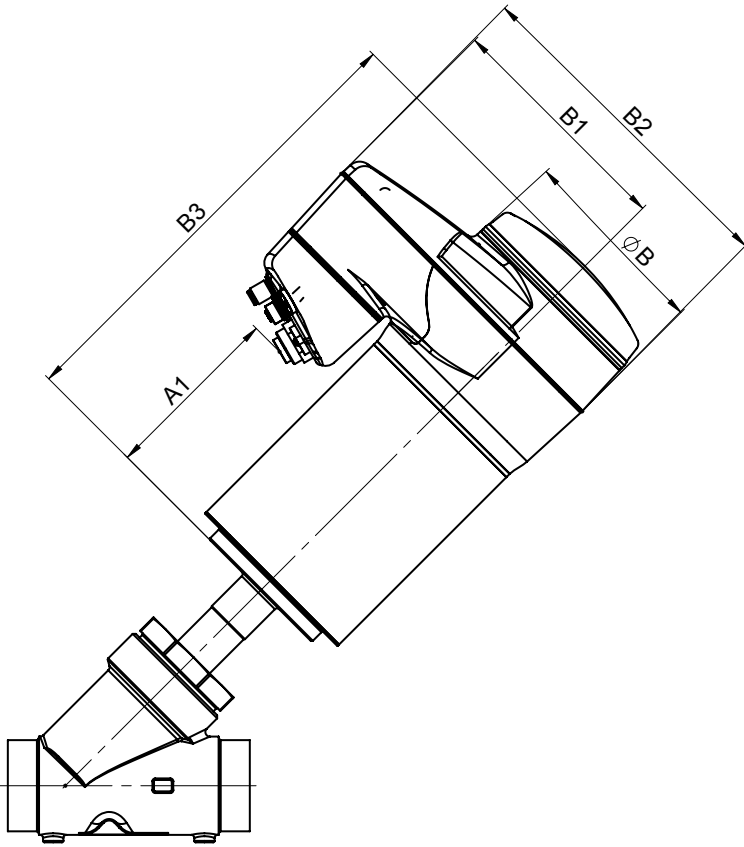

Actuator version	A1	B	B1	B2	B3
0A	45.0	68.0	126.0	160.0	193.0
1A	86.0	82.0	132.0	172.0	252.0
2A	121.0	129.0	157.0	224.0	304.0

Dimensions in mm

Body dimensions

Spigot

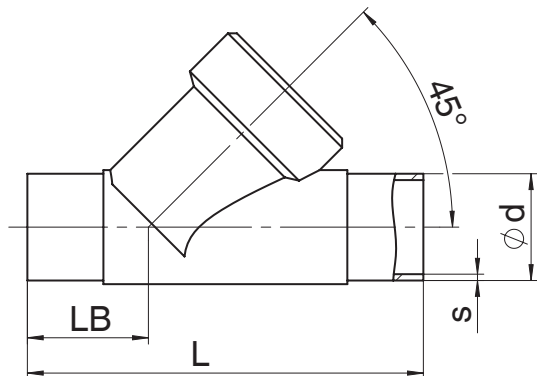

DN	Connection types code ¹⁾											
			0		16		17		18		60	
	Material code 34 ²⁾											
	L	LB	ø d	s	ø d	s	ø d	s	ø d	s	ø d	s
10	105.0	35.5	-	-	12.0	1.0	13.0	1.5	14.0	2.0	17.2	1.6
15	105.0	35.5	18.0	1.5	18.0	1.0	19.0	1.5	20.0	2.0	21.3	1.6
20	120.0	39.0	22.0	1.5	22.0	1.0	23.0	1.5	24.0	2.0	26.9	1.6
25	125.0	38.5	28.0	1.5	28.0	1.0	29.0	1.5	30.0	2.0	33.7	2.0
40	160.0	47.0	40.0	1.5	40.0	1.0	41.0	1.5	42.0	2.0	48.3	2.0
32	155.0	48.0	-	-	34.0	1.0	35.0	1.5	36.0	2.0	42.4	2.0
50	180.0	48.0	52.0	1.5	52.0	1.0	53.0	1.5	54.0	2.0	60.3	2.0

Dimensions in mm

1) **Connection type**

Code 0: Spigot DIN

Code 16: Spigot EN 10357 series B, formerly DIN 11850 series 1

Code 17: Spigot EN 10357 series A (formerly DIN 11850 series 2)/DIN 11866 series A

Code 18: Spigot DIN 11850 series 3

Code 60: Spigot ISO 1127/EN 10357 series C/DIN 11866 series B

2) **Valve body material**

Code 34: 1.4435, investment casting

Spigot

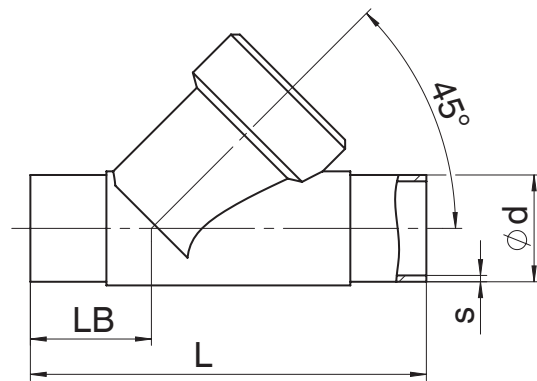

DN	Connection types code ¹⁾							
	37				59		65	
	Material code 34 ²⁾							
	L	LB	ø d	s	ø d	s	ø d	s
15	105.0	35.5	-	-	12.70	1.65	21.3	2.77
20	120.0	39.0	-	-	19.05	1.65	26.7	2.87
25	125.0	38.5	25.0	1.2	25.40	1.65	33.4	3.88
40	160.0	47.0	38.0	1.2	38.10	1.65	42.4	3.56
32	155.0	48.0	-	-	-	-	48.3	3.68
50	180.0	48.0	51.0	1.2	50.80	1.65	60.3	3.91

Dimensions in mm

1) **Connection type**

Code 37: Spigot SMS 3008

Code 59: Spigot ASME BPE

Code 65: Spigot ANSI/ASME B36.19M schedule 40s

2) **Valve body material**

Code 34: 1.4435, investment casting

Spigot

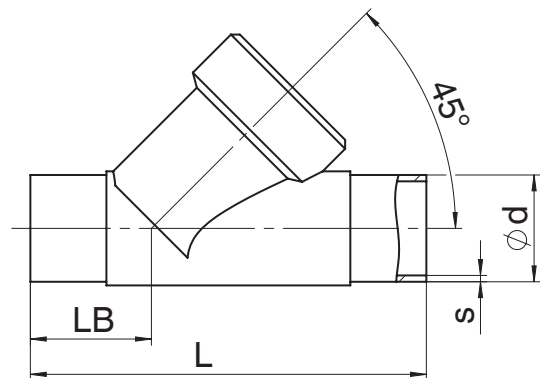

DN	Connection types code ¹⁾											
	17		37		59		60		63			
	Material code ²⁾ 37											
	L	LB	ø d	s	ø d	s	ø d	s	ø d	s	ø d	s
15	100.0	33.0	19.0	1.5	-	-	-	-	21.3	1.6	21.3	2.11
20	108.0	33.0	23.0	1.5	-	-	-	-	26.9	1.6	26.7	2.11
25	112.0	32.0	29.0	1.5	-	-	-	-	33.7	2.0	33.4	2.75
40	146.0	40.0	41.0	1.5	-	-	-	-	48.3	2.0	-	-
32	137.0	39.0	35.0	1.5	-	-	-	-	42.4	2.0	48.3	2.77
50	160.0	38.0	53.0	1.5	-	-	-	-	60.3	2.0	60.3	2.77
65	290.0	96.0	70.0	2.0	63.5	1.6	63.50	1.65	76.1	2.0	73.0	3.05
80	310.0	95.0	85.0	2.0	76.1	1.6	76.20	1.65	88.9	2.3	88.9	3.05

Dimensions in mm

1) **Connection type**

- Code 17: Spigot EN 10357 series A (formerly DIN 11850 series 2)/DIN 11866 series A
- Code 37: Spigot SMS 3008
- Code 59: Spigot ASME BPE
- Code 60: Spigot ISO 1127/EN 10357 series C/DIN 11866 series B
- Code 63: Spigot ANSI/ASME B36.19M schedule 10s

2) **Valve body material**

- Code 37: 1.4408, investment casting

Spigot

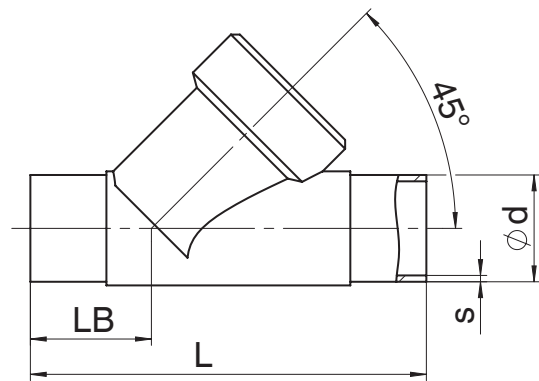

DN	Connection types code ¹⁾							
	17				59		60	
	Material code C2 ²⁾							
	L	LB	ø d	s	ø d	s	ø d	s
8	105.0	35.5	-	-	-	-	13.5	1.6
10	105.0	35.5	13.0	1.5	-	-	17.2	1.6
15	105.0	35.5	19.0	1.5	12.70	1.65	21.3	1.6
20	120.0	39.0	23.0	1.5	19.05	1.65	26.9	1.6
25	125.0	39.5	29.0	1.5	25.40	1.65	33.7	2.0
40	160.0	47.0	41.0	1.5	38.10	1.65	48.3	2.0
32	155.0	48.0	35.0	1.5	-	-	42.4	2.0
50	180.0	48.0	53.0	1.5	50.80	1.65	60.3	2.0
65	290.0	96.0	70.0	2.0	63.50	1.65	76.1	2.0
80	310.0	95.0	85.0	2.0	76.20	1.65	88.9	2.3

Dimensions in mm

1) **Connection type**

Code 17: Spigot EN 10357 series A (formerly DIN 11850 series 2)/DIN 11866 series A

Code 59: Spigot ASME BPE

Code 60: Spigot ISO 1127/EN 10357 series C/DIN 11866 series B

2) **Valve body material**

Code C2: 1.4435, investment casting

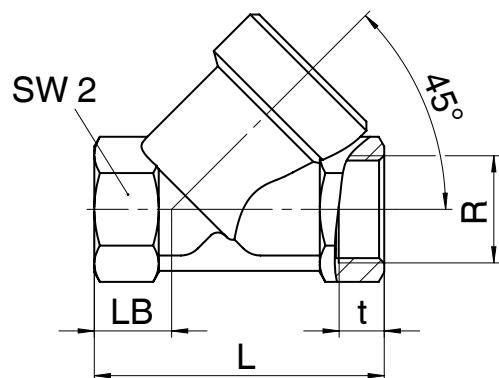
Threaded socket, body configuration D

DN	Connection types code 1 ¹⁾				
	Material code 37 ²⁾				
	L	LB	SW2	R	t
10	65.0	16.5	27.0	G 3/8	11.4
15	65.0	16.5	27.0	G 1/2	15.0
20	75.0	17.5	32.0	G 3/4	16.3
25	90.0	24.0	41.0	G 1	19.1
32	110.0	33.0	50.0	G 1¼	21.4
40	120.0	30.0	55.0	G 1½	21.4
50	150.0	40.0	70.0	G 2	25.7
65	190.0	46.0	85.0	G 2½	30.2
80	220.0	50.0	100.0	G 3	33.3

Dimensions in mm

1) **Connection type**

Code 1: Threaded socket DIN ISO 228

2) **Valve body material**

Code 37: 1.4408, investment casting

Threaded socket, body configuration D

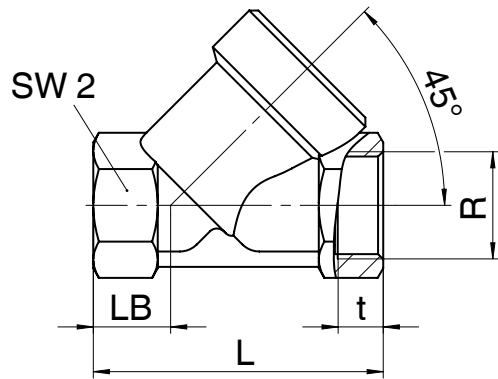

DN	Connection types code ¹⁾									
	3C					3D				
	Material code 37 ²⁾									
	L	LB	SW2	R	t	L	LB	SW2	R	t
15	65.0	16.5	27.0	Rc 1/2	15.0	65.0	16.5	27.0	1/2" NPT	13.6
20	75.0	17.5	32.0	Rc 3/4	16.3	75.0	17.5	32.0	3/4" NPT	14.1
25	90.0	24.0	41.0	Rc 1	19.1	90.0	24.0	41.0	1" NPT	17.0
32	110.0	33.0	50.0	Rc 1¼	21.4	110.0	33.0	50.0	1¼" NPT	17.5
40	120.0	30.0	55.0	Rc 1½	21.4	120.0	30.0	55.0	1½" NPT	17.3
50	150.0	40.0	70.0	Rc 2	25.7	150.0	40.0	70.0	2" NPT	17.8
65	190.0	46.0	85.0	Rc 2½	30.2	190.0	46.0	85.0	2½" NPT	23.7
80	220.0	50.0	100.0	Rc 3	33.3	220.0	50.0	100.0	3" NPT	25.8

Dimensions in mm

1) **Connection type**

Code 3C: Threaded socket Rc ISO 7-1, EN 10226-1, JIS B 0203, BS 21, end-to-end dimension ETE DIN 3202-4 series M8

Code 3D: Threaded socket NPT, end-to-end dimension ETE DIN 3202-4 series M8

2) **Valve body material**

Code 37: 1.4408, investment casting

Threaded socket, body configuration E

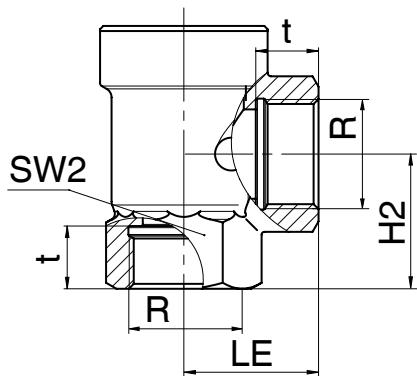

DN	Connection types code ¹⁾									
	1					3D				
	Material code 37 ²⁾									
	SW2	LE	H2	R	t	SW2	LE	H2	R	t
15	27.0	30.0	30.0	G 1/2	15.0	27.0	30.0	30.0	1/2" NPT	13.6
20	32.0	35.0	37.5	G 3/4	16.3	32.0	35.0	37.5	3/4" NPT	14.1
25	41.0	41.0	41.0	G 1	19.1	41.0	41.0	41.0	1" NPT	17.0
32	50.0	50.0	48.0	G 1 ¼	21.4	50.0	50.0	48.0	1 ¼" NPT	17.5
40	55.0	50.0	55.0	G 1 ½	21.4	55.0	50.0	55.0	1 ½" NPT	17.3
50	70.0	60.0	62.0	G 2	25.7	70.0	60.0	62.0	2" NPT	17.8

Dimensions in mm

1) **Connection type**

Code 1: Threaded socket DIN ISO 228

Code 3D: Threaded socket NPT, end-to-end dimension ETE DIN 3202-4 series M8

2) **Valve body material**

Code 37: 1.4408, investment casting

Threaded spigot

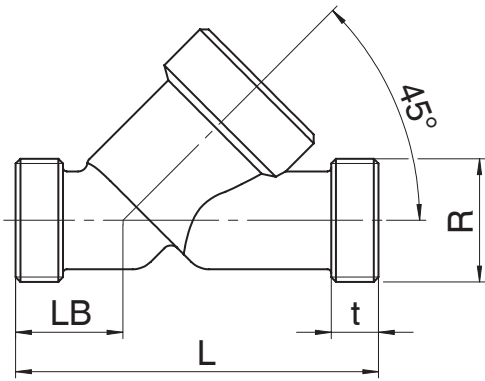

DN	Connection types code 9 ¹⁾			
	Material code 37 ²⁾			
	L	LB	R	t
15	90.0	25.0	G 3/4	12.0
20	110.0	30.0	G 1	15.0
25	118.0	30.0	G 1¼	15.0
32	130.0	38.0	G 1½	13.0
40	140.0	35.0	G 1¾	13.0
50	175.0	50.0	G 2¾	15.0
65	216.0	52.0	G 3	15.0
80	254.0	64.0	G 3½	18.0

Dimensions in mm

- 1) **Connection type**
Code 9: Threaded spigot DIN ISO 228
- 2) **Valve body material**
Code 37: 1.4408, investment casting

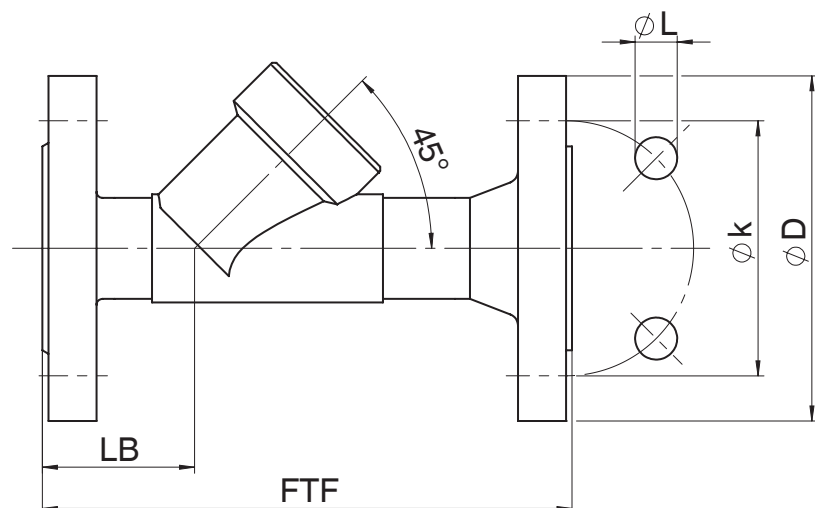
Flange, length EN 558, series 1

DN	Connection types code 10 ¹⁾					
	Material code 37 ²⁾					
	FTF	LB	ø D	ø L	ø k	n
15	130.0	33.0	95.0	14.0	65.0	4
20	150.0	45.0	105.0	14.0	75.0	4
25	160.0	44.0	115.0	14.0	85.0	4
32	180.0	51.0	140.0	18.0	100.0	4
40	200.0	52.0	150.0	18.0	110.0	4
50	230.0	50.0	165.0	18.0	125.0	4

Dimensions in mm

n = number of bolts

1) **Connection type**

Code 10: Flange EN 1092, PN 25, form B, face-to-face dimension FTF EN 558 series 1, ISO 5752, basic series 1

2) **Valve body material**

Code 37: 1.4408, investment casting

Flange, special length

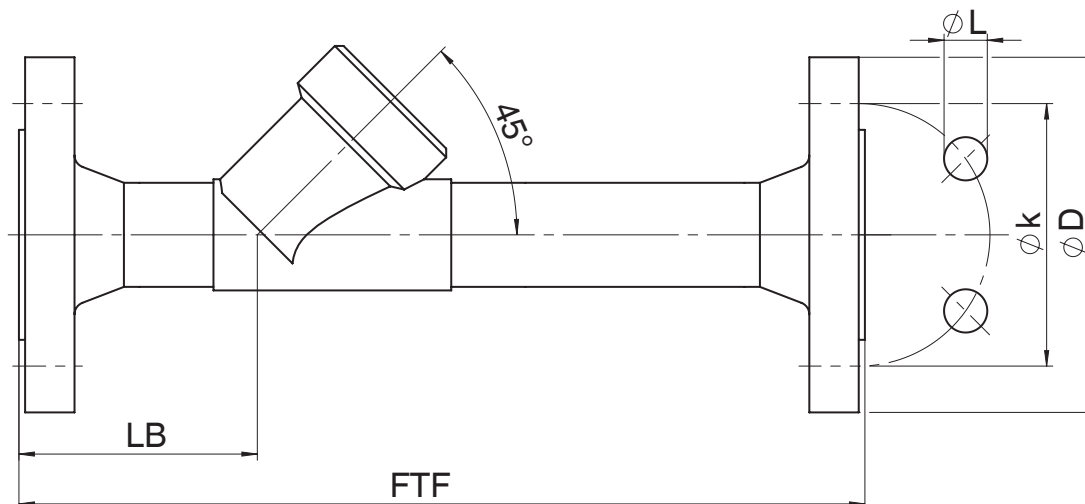

DN	Connection types code ¹⁾									
	13						47			
	Material code 34 ²⁾									
	FTF	LB	ø D	ø L	ø k	n	ø D	ø L	ø k	n
15	210.0	72.0	95.0	14.0	65.0	4	89.0	15.7	60.5	4
20	280.0	78.0	105.0	14.0	75.0	4	98.6	15.7	69.8	4
25	280.0	77.0	115.0	14.0	85.0	4	108.0	15.7	79.2	4
32	310.0	89.0	140.0	18.0	100.0	4	117.3	15.7	88.9	4
40	320.0	91.0	150.0	18.0	110.0	4	127.0	15.7	98.6	4
50	330.0	95.0	165.0	18.0	125.0	4	152.4	19.1	120.7	4

Dimensions in mm
n = number of bolts

- 1) **Connection type**
Code 13: Flange EN 1092, PN 25, form B
Code 47: Flange ANSI Class 150 RF
- 2) **Valve body material**
Code 34: 1.4435, investment casting

Clamp DIN

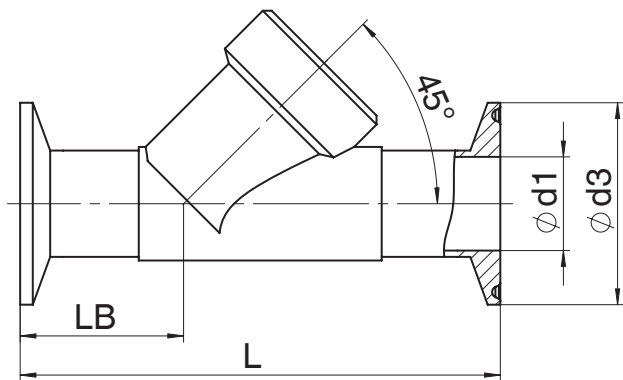

DN	Connection types code 82 ¹⁾								
	Material code ²⁾								
	34				C2				
	NPS	LB	L	ø d1	ø d3	LB	L	ø d1	ø d3
15	1/2"	47.5	130.0	18.1	50.5	47.5	130.0	18.1	50.5
20	3/4"	54.0	150.0	23.7	50.5	54.0	150.0	23.7	50.5
25	1"	56.0	160.0	29.7	50.5	56.0	160.0	29.7	50.5
32	1 ¼"	62.0	180.0	38.4	64.0	62.0	180.0	38.4	64.0
40	1 ½"	67.0	200.0	44.3	64.0	67.0	200.0	44.3	64.0
50	2"	73.0	230.0	56.3	77.5	73.0	230.0	56.3	77.5
65	2 ½"	-	-	-	-	120.0	290.0	72.1	91.0
80	3"	-	-	-	-	119.0	310.0	84.3	106.0

DN	Connection types code 86 ¹⁾								
	Material code ²⁾								
	34				C2				
	NPS	LB	L	ø d1	ø d3	LB	L	ø d1	ø d3
15	1/2"	47.5	130.0	16.0	34.0	47.5	130.0	16.0	34.0
20	3/4"	54.0	150.0	20.0	34.0	54.0	150.0	20.0	34.0
25	1"	56.0	160.0	26.0	50.5	56.0	160.0	26.0	50.5
32	1 ¼"	62.0	180.0	32.0	50.5	62.0	180.0	32.0	50.5
40	1 ½"	67.0	200.0	38.0	50.5	67.0	200.0	38.0	50.5
50	2"	73.0	230.0	50.0	64.0	73.0	230.0	50.0	64.0
65	2 ½"	-	-	-	-	120.0	290.0	66.0	91.0
80	3"	-	-	-	-	119.0	310.0	81.0	106.0

Dimensions in mm

1) **Connection type**

Code 82: Clamp DIN 32676 series B, face-to-face dimension FTF EN 558 series 1
 Code 86: Clamp DIN 32676 series A, face-to-face dimension FTF EN 558 series 1

2) **Valve body material**

Code 34: 1.4435, investment casting
 Code C2: 1.4435, investment casting

Clamp ASME

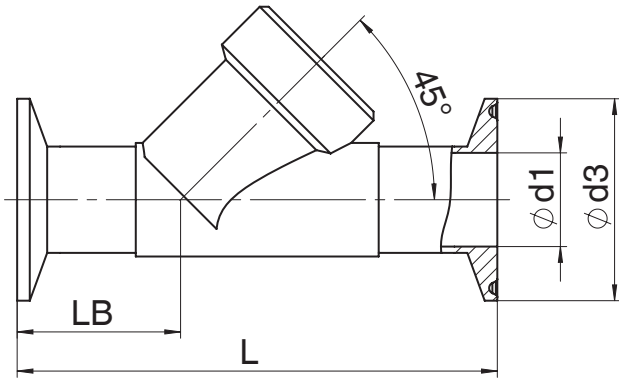

DN	Connection types code ¹⁾												
	80						88						
	Material code ²⁾												
	NPS	34				34				C2			
	LB	L	ø d1	ø d3	LB	L	ø d1	ø d3	LB	L	ø d1	ø d3	
15	1/2"	33.5	101.6	9.40	25.0	47.5	130.0	9.40	25.0	47.5	130.0	9.40	25.0
20	3/4"	30.0	101.6	15.75	25.0	54.0	150.0	15.75	25.0	54.0	150.0	15.75	25.0
25	1"	33.0	114.3	22.10	50.5	56.0	160.0	22.10	50.5	56.0	160.0	22.10	50.5
32	1 1/4"	-	-	-	-	-	-	-	-	-	-	-	-
40	1 1/2"	37.0	139.7	34.80	50.5	67.0	200.0	34.80	50.5	67.0	200.0	34.80	50.5
50	2"	36.5	158.8	47.50	64.0	73.0	230.0	47.50	64.0	73.0	230.0	47.50	64.0
65	2 1/2"	-	-	-	-	-	-	-	-	120.0	290.0	60.20	77.5
80	3"	-	-	-	-	-	-	-	-	119.0	310.0	72.90	91.0

Dimensions in mm

- 1) **Connection type**
 Code 80: Clamp ASME BPE, face-to-face dimension FTF ASME BPE
 Code 88: Clamp ASME BPE, face-to-face dimension FTF EN 558 series 1
- 2) **Valve body material**
 Code 34: 1.4435, investment casting
 Code C2: 1.4435, investment casting

Accessories

GEMÜ 1218



The GEMÜ 1218 is a connector (cable socket / cable plug), 7-pin. Straight and/or 90° angled plug type.

Ordering information

GEMÜ 1218 Binder connector			
Connection X1 – supply voltage, relay outputs			
Binder plug	Mating connector 468/ eSy series	Terminal compartment/ screws, 7-pin	88220649 ¹⁾
		Terminal compartment/ screws, 7-pin, 90°	88377714

1) provided in the scope of delivery



GEMÜ 1219

Cable socket / cable plug M12

The GEMÜ 1219 is a connector (cable socket / cable plug) M12, 5-pin. Straight and/or 90° angled plug type. Defined cable length or with threaded connection without cable. Various materials available for the fixing nut.

Ordering information

GEMÜ 1219 Ethernet/M12 cable			
Connection X2 - network connection			
M12 cable plug, straight, 4-pin	Fitted with a 1 metre cable set	Ethernet RJ45	88450499
	Fitted with a 4 metre cable set		88450500
	Fitted with a 15 metre cable set		88450502
Connection X3 – analogue/digital inputs and outputs			
M12 cable socket, straight, 8-pin	Without cable dia. 6-8 mm		88304829 ¹⁾
	Fitted with a 2 metre cable set, PVC/grey		88475143
	Fitted with a 5 metre cable set, PVC/grey		88475147
M12 cable socket, angled, 8-pin	Without cable dia. 6-8 mm		88422823
	Fitted with a 5 metre cable set, PUR black cable		88374574
Connection X4 – actual value supply, actual value input			
M12 cable plug, straight, 5-pin	Without cable PG7	Nickel-plated brass	88208641 ¹⁾
	Fitted with a 2 metre cable set, PUR black cable	5 x 0.34, nickel-plated brass	88208643
	Fitted with a 5 metre cable set, PUR black cable	5 x 0.34, nickel-plated brass	88208644
M12 cable plug, angled, 5-pin	Without cable dia. 6-8 mm	Nickel-plated brass	88208645
	Fitted with a 2 metre cable set, PUR black cable	5 x 0.34, nickel-plated brass	88208649
	Fitted with a 5 metre cable set, PUR black cable	5 x 0.34, nickel-plated brass	88208650

1) provided in the scope of delivery

Specification sheet

for designing regulating cones for globe valves

Project (customer) _____ Valve/TAG number _____

Date _____ Telephone _____

Contact person _____ E-Mail _____

Technical requirements

Medium ¹⁾ _____

Requirement characteristic	1st operating point maximum flow	2nd operating point medium flow	3rd operating point minimum flow
Media temperature ⁴⁾			
Inlet pressure			
Outlet pressure			
Flow rate ^{2,3)}			
in [m ³ /h] for liquids			
Gases ⁶⁾			
in [kg/h] for steam			

Valve body / Actuator	Type			
	Required valve DN			
	Max. operating pressure			
	Ambient temperature ⁵⁾			
	Max. media temperature			
	Connection			
	Body material			
	Seat seal	PTFE	Other	
	Control function	NC (normally closed)	DA (double acting)	Double acting (normally open)
	Control pressure	min	max	
Regulating cone	Characteristic	linear	modified equal-percentage	
	Other			

1) Liquid or gas?

For media other than water or air, it is necessary to give data for the density and viscosity (with unit of measurement) of the medium. Otherwise we will assume data for standard conditions.

2) For steam especially, the minimum or maximum flow rate should be assigned to the appropriate inlet or outlet pressure. The temperature of the medium should also be taken into account.

3) GEMÜ recommends a positioning ratio of 1 : 10 (e.g. minimum flow rate is 10 m³/h and the maximum flow rate is 100 m³/h). Please note that the valve only controls reliably from a flow of

about 10% of the max. Kv value on account of the valve opening behaviour. Other positioning ratios are possible on request or in the selection of standard regulating cones.

4) The media temperature range must be specified for steam applications. T = 20 °C is assumed unless specified otherwise.

5) This data is not absolutely necessary. A room temperature of 20 °C is assumed unless specified otherwise.

6) Basis: standard conditions 0 °C, 1013.25 mbar. If conditions differ, please specify them.



GEMÜ Gebr. Müller Apparatebau GmbH & Co. KG
Fritz-Müller-Straße 6-8, 74653 Ingelfingen-Criesbach,
Germany
Phone +49 (0)7940 123-0 · info@gemue.de
www.gemu-group.com