

Angle Seat Globe Valve, Metal

Construction

The GEMÜ 550 pneumatically operated 2/2 way angle seat globe valve has a low maintenance piston actuator. The valve spindle is sealed by a self-adjusting gland packing providing low maintenance and reliable valve spindle sealing even after a long service life. The wiper ring fitted in front of the gland packing protects it against contamination and damage.

Features

- Suitable for inert and corrosive* liquid and gaseous media
- Substantially reduced installation dimensions when using the body with male threads which can be installed using union nuts
- Materials of all medium wetted parts can be selected to suit relevant applications
- Higher media temperatures
- Versions according to ATEX on request

Advantages

- Stainless steel actuator for simple cleanability, corrosive atmospheres
- Various types of valve body connections
- Good flow capability
- Low weight
- Optical position indicator is standard for NC control function (optional for NO and DA control functions).
- Accessories:
 - Electrical position indicators
 - Combi switchboxes
 - Electro-pneumatic positioners/process controllers (see data sheet GEMÜ 550 control valve)
 - Stroke limiter
- Suitable for contact with food according to Regulation (EC) No. 1935/2004
- Standard gland packing suitable for vacuum up to 20 mbar (abs.)

*See information on working medium on page 2



Actuator 0 and 1



Actuator 2 to 5

Sectional drawing

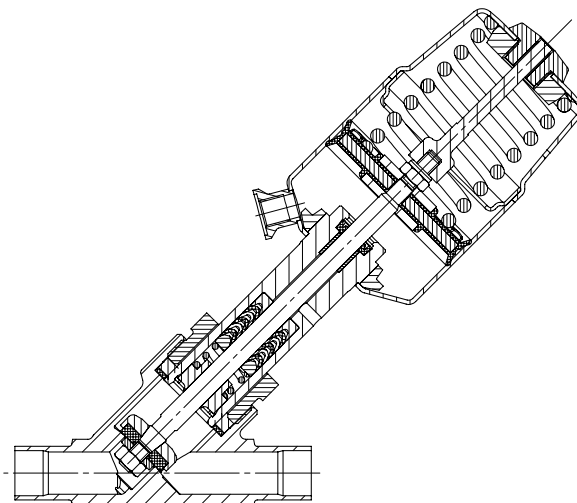

Technical data

Working medium

Corrosive, inert, gaseous and liquid media which have no negative impact on the physical and chemical properties of the body and seal material.

Max. perm. pressure of working medium see table

Medium temperature -10 °C to 180 °C

Max. permissible viscosity 600 mm²/s (cSt)

Other versions for lower/higher temperatures and viscosities on request.

Control medium

Inert gases

Max. control pressure: 8 bar

Max. perm. temperature of control medium: 60 °C

Ambient conditions

Max. ambient temperature 60 °C

Technical data / Actuator

Actuator size	Filling volume	Piston diameter
0G1, 0M1	0.006 dm ³	28 mm
1G1, 1M1	0.025 dm ³	42 mm
2G1, 2M1	0.084 dm ³	60 mm
3G1, 3M1	0.245 dm ³	80 mm
4G1	0.437 dm ³	100 mm
5G1	0.798 dm ³	130 mm

Maximum permissible seat leakage rate

Seat seal	Standard	Test procedure	Leakage rate	Test medium
PTFE	DIN EN 12266-1	P12	A	air

Max. operating pressure [bar]

Actuator size	DN 6	DN 8	DN 10	DN 15	DN 20	DN 25	DN 32	DN 40	DN 50	DN 65	DN 80
C. f. 1 Normally closed (NC) / Flow direction: under the seat											
0G1	10.0	10.0	10.0	10.0	-	-	-	-	-	-	-
1G1	-	10.0	10.0	10.0	6.0	3.5	-	-	-	-	-
2G1	-	-	22.0	22.0	12.0	7.0	4.0	2.5	-	-	-
3G1	-	-	-	-	25.0	16.0	10.0	6.0	3.0	-	-
4G1	-	-	-	-	-	25.0	18.0	12.0	7.0	-	-
5G1	-	-	-	-	-	-	25.0	20.0	15.0	10.0	7.0
C. f. 1 Normally closed (NC) / Flow direction: over the seat											
0M1	10.0	10.0	10.0	10.0	-	-	-	-	-	-	-
1M1	-	10.0	10.0	10.0	10.0	10.0	-	-	-	-	-
2M1	-	-	-	10.0	10.0	10.0	10.0	8.0	5.0	-	-
3M1	-	-	-	-	10.0	10.0	10.0	10.0	10.0	-	-
C. f. 2 Normally open (NO) / C. f. 3 Double acting (DA) / Flow direction: under the seat											
0G	20.0	20.0	20.0	20.0							
1G	-	25.0	25.0	25.0	17.0	11.0	-	-	-	-	-
2G	-	-	-	25.0	25.0	24.0	15.0	8.0	-	-	-
3G	-	-	-	-	25.0	25.0	25.0	19.0	12.0	-	-
4G	-	-	-	-	-	-	25.0	25.0	22.0	-	-
5G	-	-	-	-	-	-	25.0	25.0	25.0	25.0	18.0

All pressures are gauge pressures. When the flow is over the plug (M), there may be the danger of water hammer with liquid media! For max. operating pressures the pressure/temperature correlation must be observed (see table on page 3).

Technical data

Control pressure [bar]

C. f. 1 Normally closed (NC) / Flow direction: under the seat

Actuator size	
1G1, 2G1, 3G1, 4G1	4 - 8
0G1, 5G1	5 - 8

C. f. 1 Normally closed (NC) / Flow direction: over the seat	
0M1, 1M1, 2M1, 3M1	max. 7 bar

Higher control pressures on request.

C. f. 2 Normally open (NO) / C. f. 3 Double acting (DA) / Flow direction: under the seat

for values see diagram see page 5

Kv values [m³/h]

	DN 6	DN 8	DN 10	DN 15	DN 20	DN 25	DN 32	DN 40	DN 50	DN 65	DN 80
Butt weld spigots, DIN 11850	1.6	1.8	2.4	2.4	-	-	-	-	-	-	-
Butt weld spigots, DIN 11866	-	2.2	4.5	5.5	11.7	20.5	33.0	51.0	61.0	110.0	117.0
Threaded sockets, DIN ISO 228	-	-	4.5	5.4	10.0	15.2	23.0	41.0	68.0	95.0	130.0

Kv values determined acc. to DIN EN 60534. The Kv value data refers to control function 1 (NC) and the largest actuator for each nominal size. The Kv values for other product configurations (e.g. other connections or body materials) may differ.

Pressure / temperature correlation for angle seat globe valve bodies

Connection code	Material code	Max. allowable operating pressures in bar at temperature °C*					
		RT	100	150	200	250	300
1, 9, 17, 37, 60, 63, 3C, 3D	37	25.0	23.8	21.4	18.9	17.5	16.1
0, 16, 17, 18, 37, 59, 60, 65	34	25.0	24.5	22.4	20.3	18.2	16.1
13 (DN 15 - DN 50)	34	25.0	23.6	21.5	19.8	18.6	17.2
80, 88 (DN 15 - DN 40)	34	25.0	21.2	19.3**	-	-	-
80, 88 (DN 50 - DN 80)	34	16.0	16.0	16.0**	-	-	-
82 (DN 15 - DN 32)	34	25.0	21.2	19.3**	-	-	-
82 (DN 40 - DN 65)	34	16.0	16.0	16.0**	-	-	-
86 (DN 15 - DN 40)	34	25.0	21.2	19.3**	-	-	-
86 (DN 50 - DN 65)	34	16.0	16.0	16.0**	-	-	-
10 (DN 15 - DN 50)	37	25.0	25.0	22.7	21.0	19.8	18.5
47 (DN 15 - DN 50)	34	15.9	13.3	12.0	11.1	10.2	9.7
0, 16, 17, 18, 59, 60	40	25.0	20.6	18.7	17.1	15.8	14.8
17, 59, 60	C2	25.0	21.2	19.3	17.9	16.8	15.9

* The valves can be used down to -10°C
All pressures are gauge pressures.

** max. temperature 140 °C

RT = Room Temperature

Bleed hole in the actuator

To bleed the control medium, the pneumatic actuator has a bleed hole that is located on the side of the actuator housing (control function normally closed). In certain areas of application (e.g. the foodstuff industry), dirty water or cleaning media could enter through this bleed hole and penetrate the actuator, thereby adversely affecting correct operation. A special bleed system with lip check valve is available for these applications, which prevents such functional impairment. The bleed hole at the side is then closed.

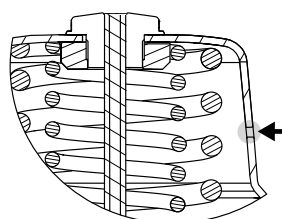

Standard bleed hole

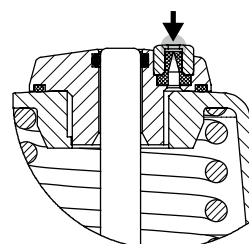

Special bleed system
K no. 6996

Operating pressure / Control pressure characteristics
Control function 1: normally closed (NC) / Flow direction: over the seat

Actuator size 0M1

Min. control pressure dependent on operating pressure

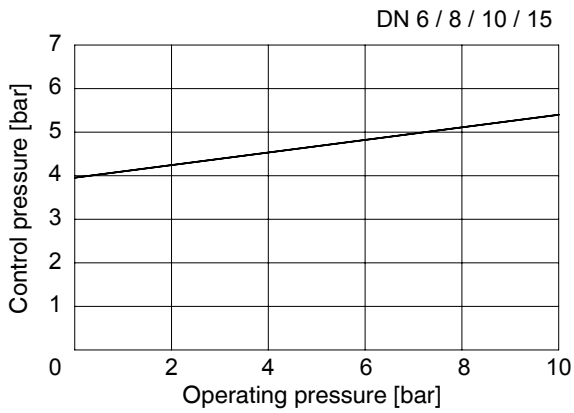

Actuator size 1M1

Min. control pressure dependent on operating pressure

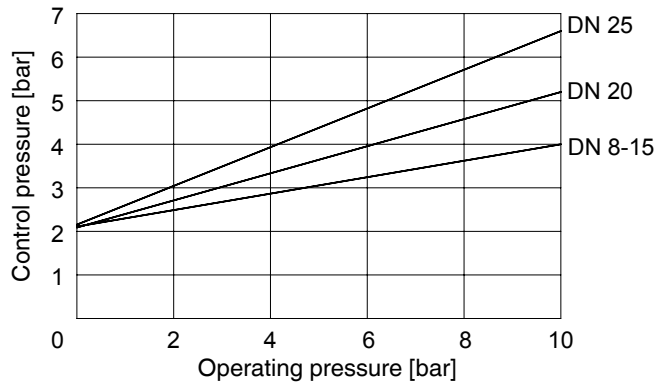

Actuator size 2M1

Min. control pressure dependent on operating pressure

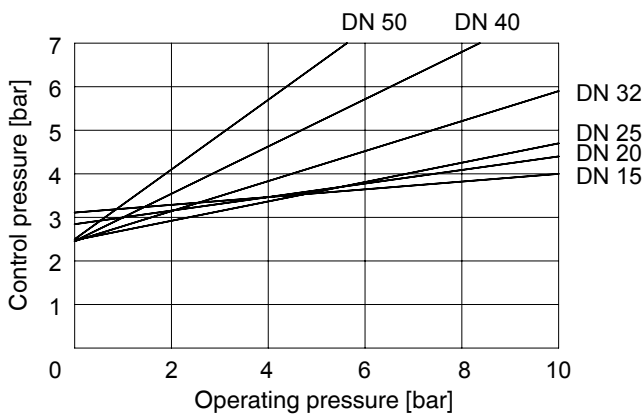

Actuator size 3M1

Min. control pressure dependent on operating pressure

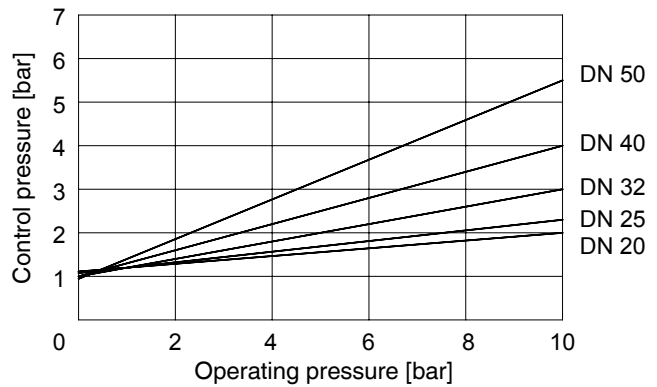

Operating pressure / Control pressure characteristics
Control function 2: normally open (NO) / Control function 3: double acting (DA)
Flow direction: under the seat

Actuator size 0G1

Min. control pressure dependent on operating pressure

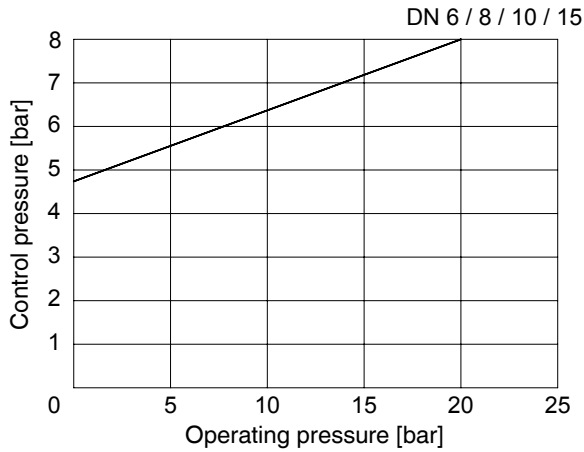

Actuator size 1G1

Min. control pressure dependent on operating pressure

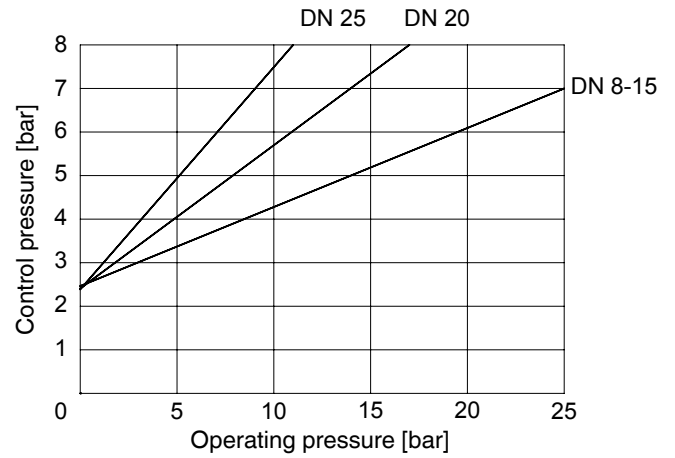

Actuator size 2G1

Min. control pressure dependent on operating pressure

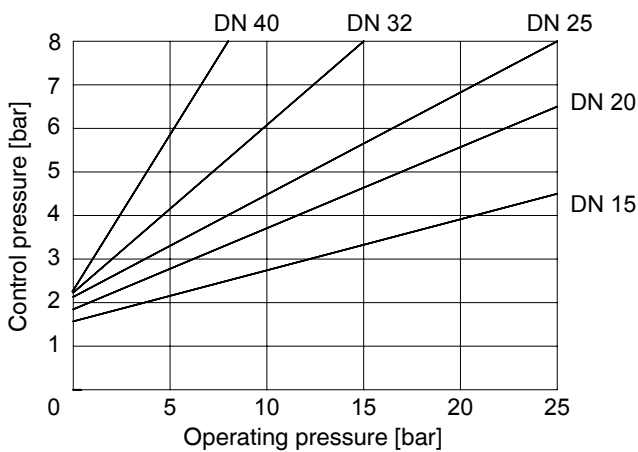

Actuator size 3G1

Min. control pressure dependent on operating pressure

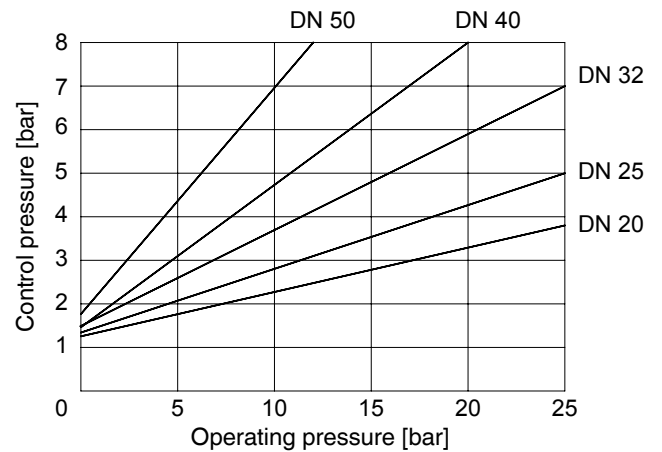

Actuator size 4G1

Min. control pressure dependent on operating pressure

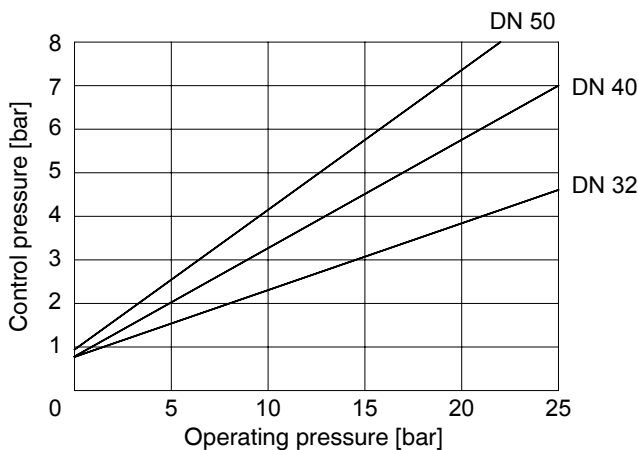

Actuator size 5G1

Min. control pressure dependent on operating pressure

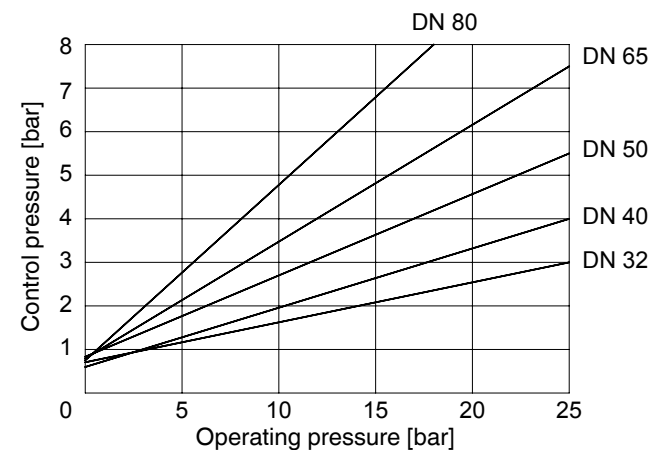

Order data

Body configuration	Code
2/2-way body	D
Angle body only in material code 37 (DN 15 - 50)	E

Seat seal	Code
PTFE	5
PTFE, glass fibre reinforced	5G
PTFE, USP Class VI	5P

Connection	Code
Butt weld spigots	
Spigots DIN	0
Spigots EN 10357 series B	16
Spigots EN 10357 series A (formerly DIN 11850 series 2) / DIN 11866 series A	17
Spigots DIN 11850 series 3	18
Spigots SMS 3008	37
Spigots ASME BPE	59
Spigots ISO 1127 / EN 10357 series C / DIN 11866 series B	60
Spigots ANSI/ASME B36.19M Schedule 10s	63
Spigots ANSI/ASME B36.19M Schedule 40s	65
Threaded connections	
Threaded sockets DIN ISO 228	1
Threaded socket Rc ISO 7-1, EN 10226-1, JIS B 0203, BS 21, end-to-end dimension ETE DIN 3202-4 series M8	3C
Threaded spigots DIN ISO 228	9
Threaded sockets NPT length DIN 3202-4 series M8	3D
Flanges	
Flanges EN 1092 / PN25 / form B, length EN 558, series 1	10
Flanges EN 1092 / PN25 /form B, length see body dimensions	13
Flanges ANSI Class 125/150 RF, length see body dimensions	47
Clamp connections	
Clamps ASME BPE for pipe ASME BPE, length ASME BPE	80
Clamps DIN 32676 series B for pipe EN ISO 1127, length EN 558, series 1	82
Clamps DIN 32676 series A for pipe DIN 11850, length EN 558, series 1	86
Clamps ASME BPE for pipe ASME BPE, length EN 558, series 1	88

Control function	Code
Normally closed (NC)	1
Normally open (NO)	2
Double acting (DA)	3

Actuator size	Code
Actuator 0 piston ø 28 mm	0
Actuator 1 piston ø 42 mm	1
Actuator 2 piston ø 60 mm	2
Actuator 3 piston ø 80 mm	3
Actuator 4 piston ø 100 mm	4
Actuator 5 piston ø 130 mm	5

Flow direction	Code
Under the seat	G*
Over the seat	M**

** only control function NC

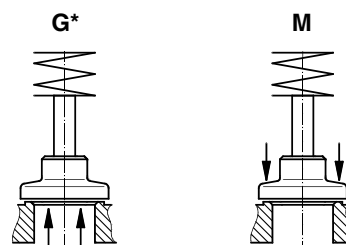

* Preferred flow direction with incompressible media to avoid "water hammer"

Valve body material	Code
1.4435 (ASTM A 351 CF3M \cong 316L), Investment casting	34
1.4408, Investment casting	37
1.4435 (316 L), Forged body	40
1.4435, Investment casting Material equivalency 316L	C2*

* A surface finish from the order code table „K number“ must be specified for valve body material C2.

Spring set	Code
Standard	1

For further order data see page 7

Order data

Version	Code
Media temperature -10 to 210 °C (only with seat seal Code 5G and 10)	2023
Special bleed system in the actuator	6996
All special versions only available ex works	
Surface finish for valve body material C2	
Ra ≤ 0.6 µm (25 µinch) for process contact surfaces, in accordance with ASME BPE SF2 + SF3, mechanically polished internal	1903
Ra ≤ 0.8 µm (30 µinch) for process contact surfaces, in accordance with DIN 11866 H3, mechanically polished internal	1904
Ra ≤ 0.4 µm (15 µinch) for process contact surfaces, in accordance with DIN 11866 H4, ASME BPE SF1, mechanically polished internal	1909
Ra ≤ 0.6 µm for process contact surfaces, in accordance with ASME BPE SF6, electropolished internal/external	1953
Ra ≤ 0.8 µm for process contact surfaces, in accordance with DIN 11866 HE3, electropolished internal/external	1954
Ra ≤ 0.4 µm for process contact surfaces, in accordance with DIN 11866 HE4/ASME BPE SF5, electropolished internal/external	1959

Order example	550	15	D	1	37	5	1	1	G	1	-
Type	550										
Nominal size		15									
Body configuration (code)			D								
Connection (code)				1							
Valve body material (code)					37						
Seat seal (code)						5					
Control function (code)							1				
Actuator size (code)								1			
Flow direction (code)									G		
Spring set (code)										1	
Version (code)											-

Version for food contact

For food contact, the product must be ordered with the following ordering options:

Seat seal code 5, 5G

Valve body material code 34, 37, 40, C2

Actuator dimensions [mm]

Actuator dimensions					
Actuator size	$\varnothing B$	M	H max*	G	A2
0	32	M 12x1	6	M5	35.4
1	46	M 16x1	12	G 1/8	53.0
2	63	M 16x1	22	G 1/8	-
3	84	M 16x1	28	G 1/4	-
4	104	M 22x1.5	32	G 1/4	-
5	135	M 22x1.5	41	G 1/4	-

H max*: dependent on nominal size

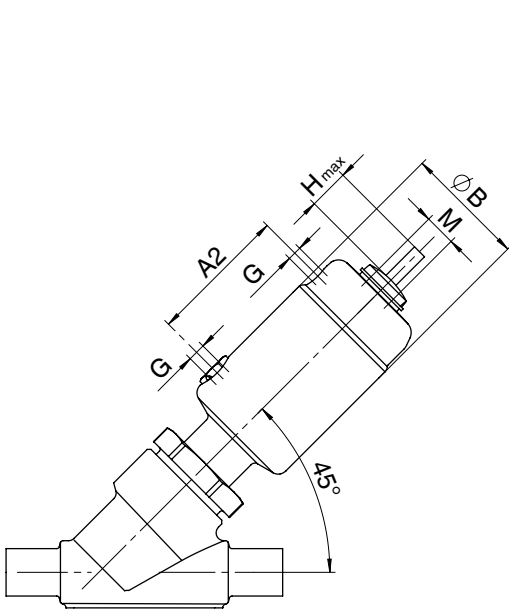

Actuator size 0, 1

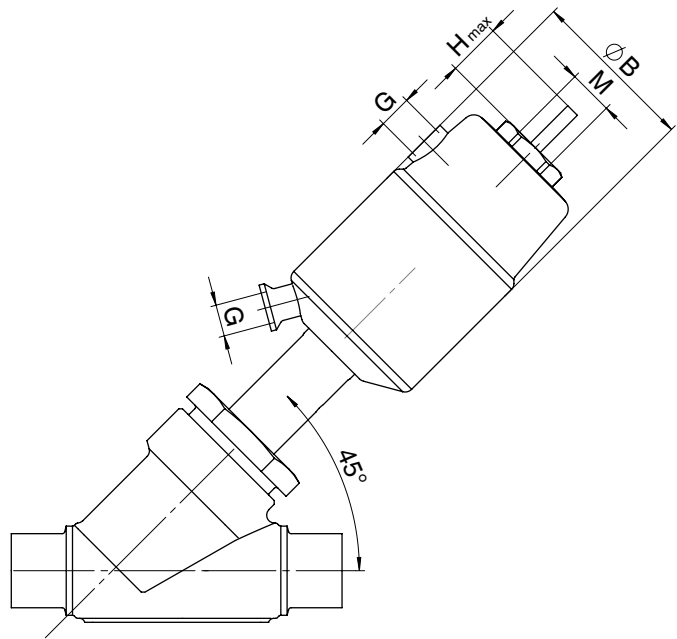

Actuator size 2 - 5

Installation dimensions - Valve with 2/2-way body [mm]

Installation dimensions / Actuator weight (without body) [kg]

DN	Nut size SW1	G	Actuator size 0		Actuator size 1		Actuator size 2		Actuator size 3		Actuator size 4		Actuator size 5	
			CT/LA	Weight	CT/LA	Weight	CT/LA	Weight	CT/LA	Weight	CT/LA	Weight	CT/LA	Weight
6	24	-	91	0.24	-	-	-	-	-	-	-	-	-	-
8	24	-	91	0.24	-	-	-	-	-	-	-	-	-	-
10	24	-	91	0.24	-	-	-	-	-	-	-	-	-	-
15	24	-	91	0.24	-	-	-	-	-	-	-	-	-	-
8	36	-	-	-	134	0.62	171	0.90	-	-	-	-	-	-
10	36	-	-	-	134	0.62	171	0.90	-	-	-	-	-	-
15	36	M 34x1,5	-	-	137	0.66	174	0.97	-	-	-	-	-	-
20	41	M 40x1,5	-	-	143	0.73	180	1.00	198	1.7	-	-	-	-
25	46	M 45x1,5	-	-	-	-	184	1.10	202	1.8	235	3.2	-	-
32	55	M 52x1,5	-	-	-	-	192	1.30	210	2.0	243	3.4	269	6.5
40	60	M 60x2,0	-	-	-	-	187	1.60	215	2.1	248	3.5	274	6.6
50	55	M 72x2,0	-	-	-	-	-	-	223	2.3	256	3.7	282	6.8
65	75	M 90x2,0	-	-	-	-	-	-	-	-	-	-	295	7.4
80	75	M 105x2,0	-	-	-	-	-	-	-	-	-	-	312	8.1

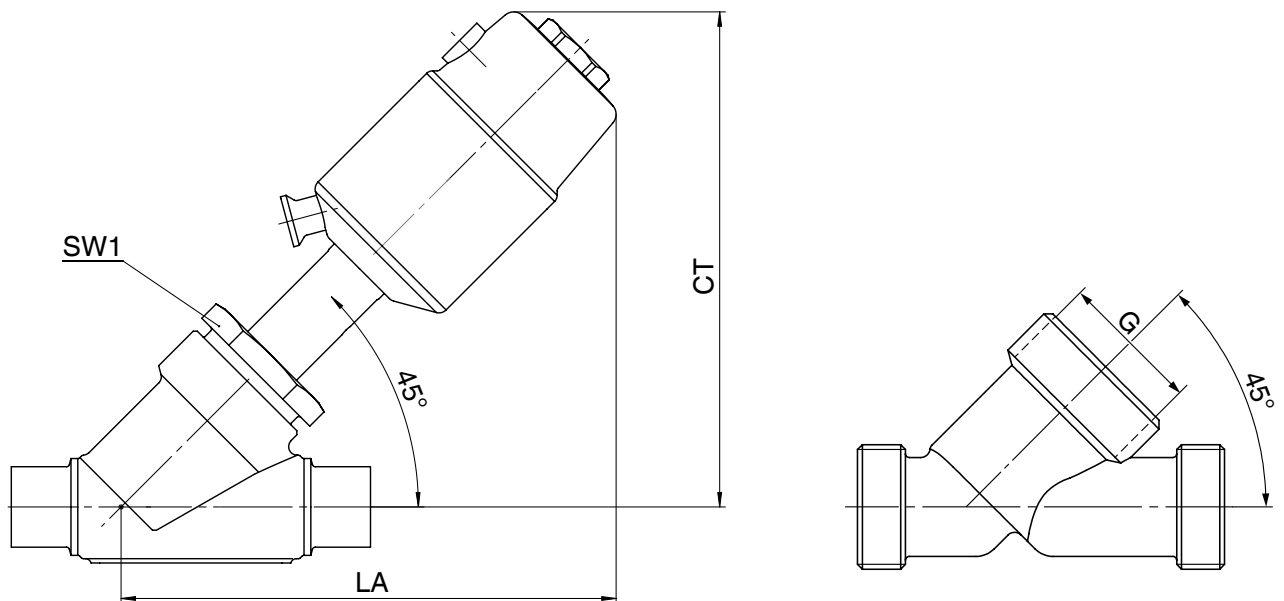

The dimensions stated refer to control function 1 (normally closed NC), for control function 2 (normally open NO) the dimensions are smaller.

Installation dimensions - Valve with angle body [mm]

Installation dimensions / Actuator weight (without body) [kg]

DN	Nut size SW1	G	Actuator size 1		Actuator size 2		Actuator size 3		Actuator size 4		Actuator size 5	
			CT	Weight	CT	Weight	CT	Weight	CT	Weight	CT	Weight
15	36	M 34x1.5	149	0.66	195	0.97	-	-	-	-	-	-
20	41	M 40x1.5	152	0.73	198	1.00	214	1.7	-	-	-	-
25	46	M 45x1.5	-	-	202	1.10	218	1.8	256	3.2	-	-
32	55	M 52x1.5	-	-	205	1.30	221	2.0	259	3.4	286	6.5
40	60	M 60x2.0	-	-	-	-	226	2.1	264	3.5	291	6.6
50	55	M 72x2.0	-	-	-	-	233	2.3	271	3.7	298	6.8

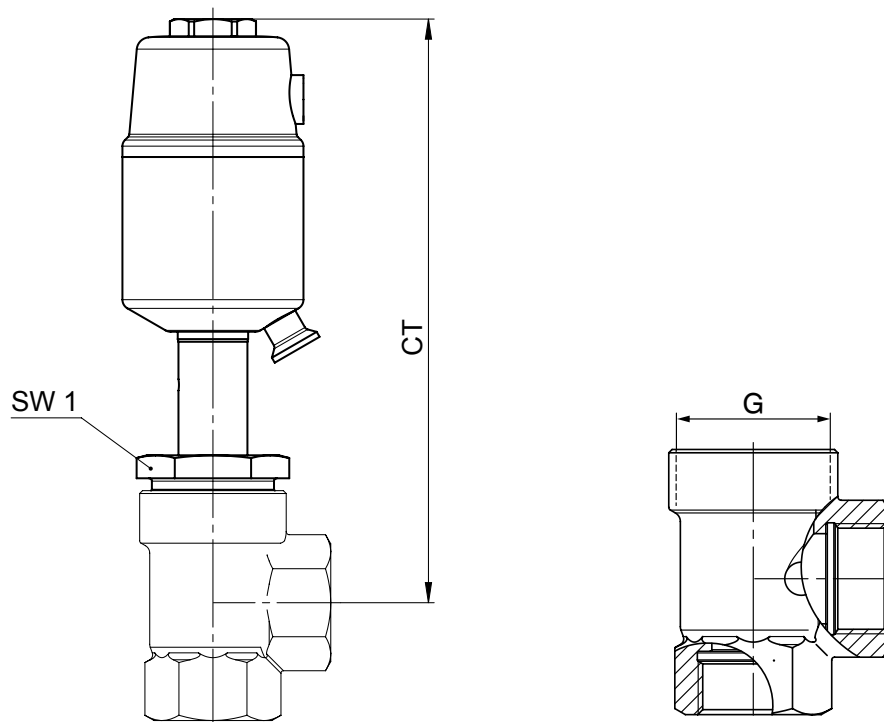

The dimensions stated refer to control function 1 (normally closed NC), for control function 2 (normally open NO) the dimensions are smaller.

Body dimensions [mm]

Butt weld spigots, connection code 0, 16, 17, 18, 37, 60
Valve body material: 1.4435 (code 34), 1.4408 (code 37)

DN	Material code 34		Material code 37		Connection code											
					0		16		17		18		37		60	
	L	LB	L	LB	ø d	s	ø d	s	ø d	s	ø d	s	ø d	s	ø d	s
10	105	35.5	-	-	-	-	12	1.0	13	1.5	14	2.0	-	-	17.2	1.6
15	105	35.5	100	33	18	1.5	18	1.0	19	1.5	20	2.0	-	-	21.3	1.6
20	120	39.0	108	33	22	1.5	22	1.0	23	1.5	24	2.0	-	-	26.9	1.6
25	125	38.5	112	32	28	1.5	28	1.0	29	1.5	30	2.0	25.0	1.2	33.7	2.0
32	155	48.0	137	39	-	-	34	1.0	35	1.5	36	2.0	-	-	42.4	2.0
40	160	47.0	146	40	40	1.5	40	1.0	41	1.5	42	2.0	38.0	1.2	48.3	2.0
50	180	48.0	160	38	52	1.5	52	1.0	53	1.5	54	2.0	51.0	1.2	60.3	2.0
65	-	-	290	96	-	-	-	-	70	2.0	-	-	63.5	1.6	76.1	2.0
80	-	-	310	95	-	-	-	-	85	2.0	-	-	76.1	1.6	88.9	2.3

For materials see overview on page 16/17

Butt weld spigots, connection code 59, 63, 65
Valve body material: 1.4435 (code 34), 1.4408 (code 37)

DN	Material code 34		Material code 37		Connection code						
					59		63		65		
	L	LB	L	LB	ø d	s	ø d	s	ø d	s	
10	105	35.5	-	-	-	-	-	-	-	-	-
15	105	35.5	100	33	12.70	1.65	21.3	2.11	21.3	2.77	
20	120	39.0	108	33	19.05	1.65	26.7	2.11	26.7	2.87	
25	125	38.5	112	32	25.40	1.65	33.4	2.75	33.4	3.88	
32	155	48.0	137	39	-	-	-	-	42.4	3.56	
40	160	47.0	146	40	38.10	1.65	48.3	2.77	48.3	3.68	
50	180	48.0	160	38	50.80	1.65	60.3	2.77	60.3	3.91	
65	-	-	290	96	63.50	1.65	73.0	3.05	-	-	
80	-	-	310	95	76.20	1.65	88.9	3.05	-	-	

For materials see overview on page 16/17

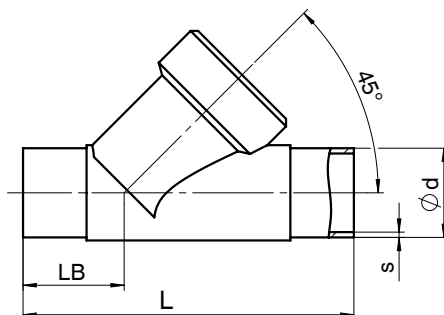

Body dimensions [mm]

Butt weld spigots, connection code 0, 16, 17, 18, 59, 60 Valve body material: Forged body (code 40)

			Connection code											
			0		16		17		18		59		60	
DN	L	LB	ø d	s	ø d	s	ø d	s	ø d	s	ø d	s	ø d	s
6*	80	26.5	8	1.0	-	-	-	-	-	-	-	-	-	-
8*	80	26.5	10	1.0	-	-	-	-	-	-	-	-	13.5	1.6
10*	80	26.5	-	-	12	1.0	13	1.5	14	2.0	9.53	0.89	-	-
15*	80	26.5	-	-	-	-	-	-	-	-	12.70	1.65	-	-

* only with actuator size 0

Butt weld spigots, connection code 17, 59, 60 Valve body material: 1.4435 (code C2)

			Connection code					
			17		60		59	
DN	L	LB	ø d	s	ø d	s	ø d	s
8	105*	35.5*	-	-	13.5	1.6	-	-
10	105	35.5	13	1.5	17.2	1.6	-	-
15	105	35.5	19	1.5	21.3	1.6	12.70	1.65
20	120	39.0	23	1.5	26.9	1.6	19.05	1.65
25	125	39.5	29	1.5	33.7	2.0	25.40	1.65
32	155	48.0	35	1.5	42.4	2.0	-	-
40	160	47.0	41	1.5	48.3	2.0	38.10	1.65
50	180	48.0	53	1.5	60.3	2.0	50.80	1.65
65	290	96.0	70	2.0	76.1	2.0	63.50	1.65
80	310	95.0	85	2.0	88.9	2.3	76.20	1.65

* Connection code 1A: L = 100, LB = 33,5

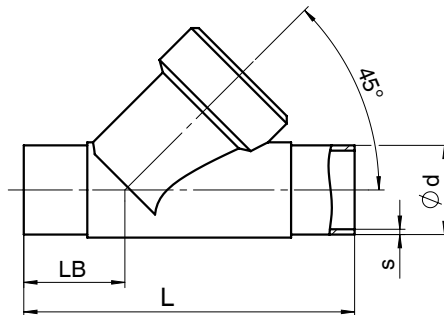

Body dimensions [mm]

Threaded sockets DIN, connection code 1 Valve body material: 1.4408 (code 37)

DN	L	LB	R	t	SW2	
8*	65	19.0	G 1/4	12.0	17	hexagonal
10*	65	19.0	G 3/8	12.0	24	hexagonal
15*	65	19.0	G 1/2	11.4	24	hexagonal
10	65	16.5	G 3/8	11.4	27	hexagonal
15	65	16.5	G 1/2	15.0	27	hexagonal
20	75	17.5	G 3/4	16.3	32	hexagonal
25	90	24.0	G 1	19.1	41	hexagonal
32	110	33.0	G 1 1/4	21.4	50	octagonal
40	120	30.0	G 1 1/2	21.4	55	octagonal
50	150	40.0	G 2	25.7	70	octagonal
65	190	46.0	G 2 1/2	30.2	85	octagonal
80	220	50.0	G 3	33.3	100	octagonal

* only with actuator size 0

Threaded sockets NPT, BS 21 Rc, connection code 3C, 3D Valve body material: 1.4408 (code 37)

DN	L	LB	SW2	Connection code				
				3C		3D		
				R	t	R	t	
8*	65	19.0	17	hexagonal	-	-	1/4" NPT	10.1
10*	65	27.0	24	hexagonal	-	-	3/8" NPT	10.4
15*	65	27.0	24	hexagonal	-	-	1/2" NPT	13.6
15	65	16.5	27	hexagonal	Rc 1/2	15.0	1/2" NPT	13.6
20	75	17.5	32	hexagonal	Rc 3/4	16.3	3/4" NPT	14.1
25	90	24.0	41	hexagonal	Rc 1	19.1	1" NPT	17.0
32	110	33.0	50	octagonal	Rc 1 1/4	21.4	1 1/4" NPT	17.5
40	120	30.0	55	octagonal	Rc 1 1/2	21.4	1 1/2" NPT	17.3
50	150	40.0	70	octagonal	Rc 2	25.7	2" NPT	17.8
65	190	46.0	85	octagonal	Rc 2 1/2	30.2	2 1/2" NPT	23.7
80	220	50.0	100	octagonal	Rc 3	33.3	3" NPT	25.8

* only with actuator size 0

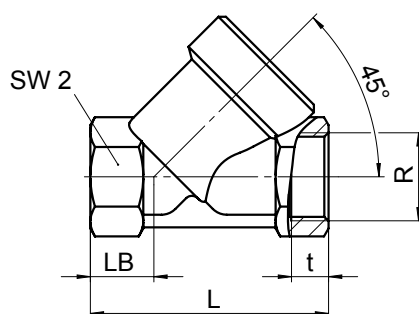

Body dimensions [mm]

Threaded sockets DIN, connection code 1, 3D / Angle body Valve body material: 1.4408 (code 37)

DN	SW2	LE	H2	Connection code 1		Connection code 3D	
				R	t	R	t
15	27	30	30.0	G 1/2	15.0	1/2" NPT	13.6
20	32	35	37.5	G 3/4	16.3	3/4" NPT	14.1
25	41	41	41.0	G 1	19.1	1" NPT	17.0
32	50	50	48.0	G 1 1/4	21.4	1 1/4" NPT	17.5
40	55	50	55.0	G 1 1/2	21.4	1 1/2" NPT	17.3
50	70	60	62.0	G 2	25.7	2" NPT	17.8

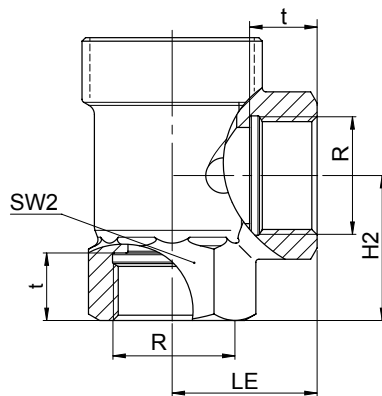

Threaded spigots, connection code 9 Valve body material: 1.4408 (code 37), Forged body (code 40)

DN	L	LB	t	R
6*	65	19	12	G 1/4
8*	65	19	12	G 3/8
10*	65	19	12	G 1/2
15*	65	19	12	G 3/4
15	90	25	12	G 3/4
20	110	30	15	G 1
25	118	30	15	G 1 1/4
32	130	38	13	G 1 1/2
40	140	35	13	G 1 3/4
50	175	50	15	G 2 3/8
65	216	52	15	G 3
80	254	64	18	G 3 1/2

*only with actuator size 0

For materials see overview on page 16/17

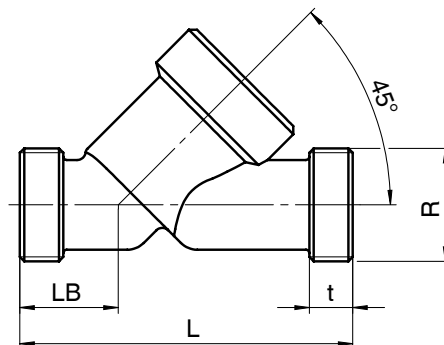

Body dimensions [mm]

**Flanges, connection code 10
Valve body material: 1.4408 (code 37)**

DN	FTF	LB	ø D	ø L	ø k	Number of bolts
15	130	33	95	14	65	4
20	150	45	105	14	75	4
25	160	44	115	14	85	4
32	180	51	140	18	100	4
40	200	52	150	18	110	4
50	230	50	165	18	125	4

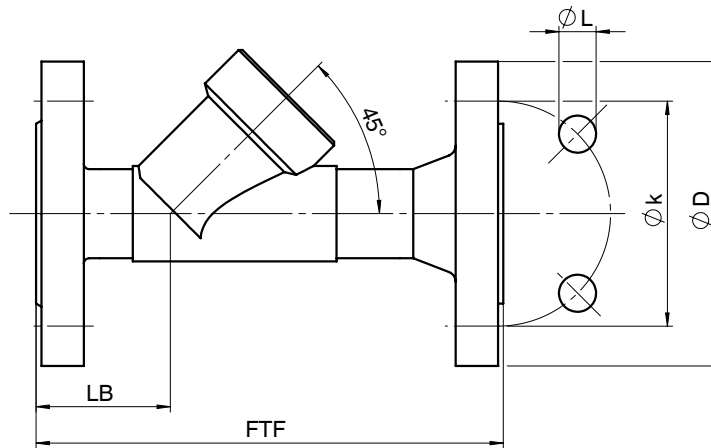

**Flanges, connection code 13, 47
Valve body material: 1.4435 (code 34)**

DN	FTF	LB	Connection code 13				Connection code 47			
			ø D	ø L	ø k	Number of bolts	ø D	ø L	ø k	Number of bolts
15	210	72	95	14	65	4	89.0	15.7	60.5	4
20	280	78	105	14	75	4	98.6	15.7	69.8	4
25	280	77	115	14	85	4	108.0	15.7	79.2	4
32	310	89	140	18	100	4	117.3	15.7	88.9	4
40	320	91	150	18	110	4	127.0	15.7	98.6	4
50	330	95	165	18	125	4	152.4	19.1	120.7	4

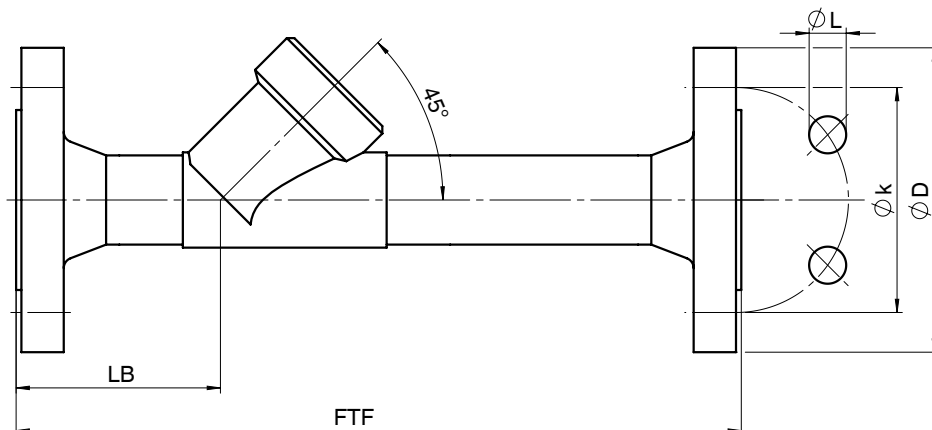

Body dimensions [mm]

Clamp connections, connection code 80, 82, 86, 88
Valve body material: 1.4435 (code 34), 1.4435 (code C2)

DN	NPS	Connection code								Connection code			
		LB	L	82		86		88		80			
				ø d1	ø d3	ø d1	ø d3	ø d1	ø d3	LB	L	ø d1	ø d3
8	1/4"	47.5	130	10.3	25.0	-	-	-	-	-	-	-	-
10	3/8"	47.5	130	14.0	25.0	-	-	-	-	-	-	-	-
15	1/2"	47.5	130	18.1	50.5	16	34.0	9.40	25.0	33.5	101.6	9.40	25.0
20	3/4"	54.0	150	23.7	50.5	20	34.0	15.75	25.0	30.0	101.6	15.75	25.0
25	1"	56.0	160	29.7	50.5	26	50.5	22.10	50.5	33.0	114.3	22.10	50.5
32	1 1/4"	62.0	180	38.4	64.0	32	50.5	-	-	-	-	-	-
40	1 1/2"	67.0	200	44.3	64.0	38	50.5	34.80	50.5	37.0	139.7	34.80	50.5
50	2"	73.0	230	56.3	77.5	50	64.0	47.50	64.0	36.5	158.8	47.50	64.0
65	2 1/2"	120.0	290	72.1	91.0	66	91.0	60.20	77.5	-	-	-	-
80	3"	119.0	310	84.3	106.0	81	106.0	72.90	91.0	-	-	-	-

For materials see overview on page 17

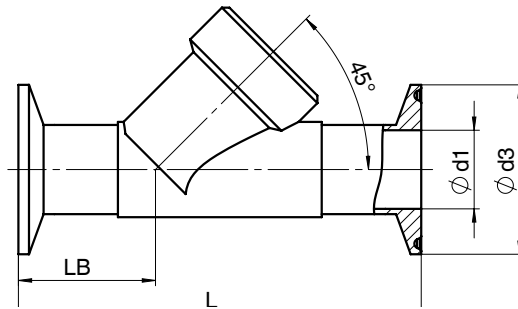

Actuators for connection code 10:

DN 15	Actuator 1 + 2
DN 20	Actuator 1 + 2 + 3
DN 25	Actuator 2 + 3 + 4
DN 32	Actuator 2
DN 40	Actuator 4
DN 50	Actuator 3 + 4

Overview of metal bodies for GEMÜ 550 with actuator size 0

Connection code	Threaded connections				Spigots					
	1	9	3D	0	16	17	18	59	60	
Material code	37	37	40	37	40	40	40	40	40	40
DN 6	-	-	X	-	X	-	-	-	-	-
DN 8	X	X	-	X	X	-	-	-	-	X
DN 10	X	X	-	X	-	X	X	X	X	-
DN 15	X	X	-	X	-	-	-	-	X	-

Overview of metal bodies for GEMÜ 550 with actuator size 1, 2, 3, 4, 5																
Connection code	Spigots															
	0	16	17			18	37		59			60			63	65
Material code	34	34	34	37	C2	34	34	37	34	37	C2	34	37	C2	37	34
DN 8	-	-	-	-	-	-	-	-	-	-	-	-	-	X	-	-
DN 10	-	X	X	-	X	-	-	-	-	-	-	X	-	X	-	-
DN 15	X	X	X	X	X	X	-	-	X	-	X	X	X	X	X	X
DN 20	X	X	X	X	X	X	-	-	X	-	X	X	X	X	X	X
DN 25	X	X	X	X	X	X	X	-	X	-	X	X	X	X	X	X
DN 32	-	X	X	X	X	X	-	-	-	-	-	X	X	X	-	X
DN 40	X	X	X	X	X	X	X	-	X	-	X	X	X	X	X	X
DN 50	X	X	X	X	X	X	X	-	X	-	X	X	X	X	X	X
DN 65	-	-	-	X	X	-	-	X	-	X	X	-	X	X	X	-
DN 80	-	-	-	X	X	-	-	X	-	X	X	-	X	X	X	-

Overview of metal bodies for GEMÜ 550 with actuator size 1, 2, 3, 4, 5																
Connection code	Threaded connections						Clamps						Flanges			
	1		3C	9	3D		80	82		86		88		10	13	47
Material code	37	37	37	37	37	37	34	34	C2	34	C2	34	C2	37	34	34
Body configuration	2/2-way body	Angle body			2/2-way body	Angle body										
DN 8	-	-	-	-	-	-	-	-	X	-	-	-	-	-	-	-
DN 10	X	-	-	-	-	-	-	-	X	-	-	-	-	-	-	-
DN 15	X	X	X	X	X	X	X	X	X	X	X	X	X	X	X*	X
DN 20	X	X	X	X	X	X	X	X	X	X	X	X	X	X	X*	X
DN 25	X	X	X	X	X	X	X	X	X	X	X	X	X	X	X*	X
DN 32	X	X	X	X	X	X	-	X	X	X	X	X	-	-	X*	X
DN 40	X	X	X	X	X	X	X	X	X	X	X	X	X	X	X*	X
DN 50	X	X	X	X	X	X	X	X	X	X	X	X	X	X	X*	X
DN 65	X	-	X	X	X	-	-	-	X	-	X	-	X	-	-	-
DN 80	X	-	X	X	X	-	-	-	X	-	X	-	X	-	-	-

*For possible combinations with actuator sizes see table page 16

For further globe valves, accessories and other products, please see our Product Range catalogue and Price List.
Contact GEMÜ.

GEMÜ VALVES, MEASUREMENT
AND CONTROL SYSTEMS

