

# GEMÜ BB02

## Ball valve with bare shaft



### Features

- Suitable for vacuum applications
- Low maintenance and reliable spindle sealing
- Antistatic device

---

### Description

The GEMÜ BB02 stainless steel 3-piece 2/2-way ball valve has a bare shaft. Thanks to the top flange according to ISO 5211, easy actuator mounting is possible.

### Technical specifications

- **Media temperature:** -20 to 180 °C
- **Ambient temperature:** -20 to 60 °C
- **Operating pressure :** 0 to 63 bar
- **Nominal sizes:** DN 8 to 100
- **Body configurations:** 2/2-way body
- **Connection types:** Flange | Spigot | Threaded connection
- **Connection standards:** ASME | DIN | EN | ISO | NPT
- **Body materials:** 1.4408, investment casting material
- **Seal materials:** PTFE
- **Conformities:** ATEX

Technical data depends on the respective configuration



## Product line

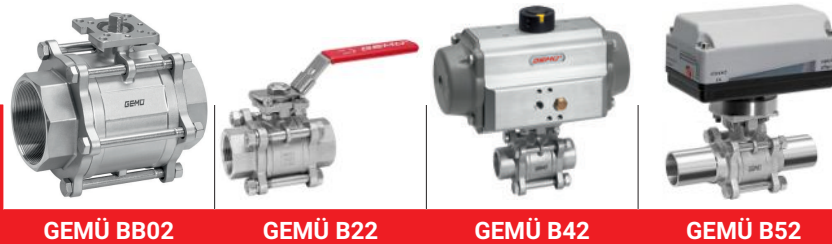

<b>Operation</b>				
With bare shaft	●	-	-	-
Manual	-	●	-	-
Pneumatic	-	-	●	-
Motorized	-	-	-	●
<b>Nominal sizes</b>	DN 8 to 100	DN 8 to 100	DN 8 to 100	DN 8 to 100
<b>Media temperature</b>	-20 to 180 °C	-20 to 180 °C	-20 to 180 °C	-20 to 180 °C
<b>Operating pressure *</b>	0 to 63 bar	0 to 63 bar	0 to 63 bar	0 to 63 bar
<b>Connection types</b>				
Flange	●	●	●	●
Spigot	●	●	●	●
Threaded connection	●	●	●	●

\* depending on version and/or operating parameters

## Product description

### Construction

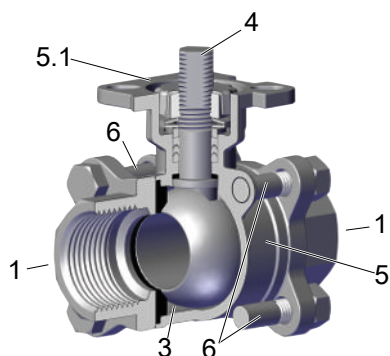

Item	Name	Materials
5	Ball valve body	1.4408 / CF8M
1	Pipe connections	1.4408 / CF8M , 1.4409 / CF3M butt weld connections
5.1	Mounting flange ISO 5211	1.4408 / CF8M
4	Ball valve shaft	1.4401 / SS316
6	Studs	A2 70
3	Seal	PTFE

### Pressure-relief hole

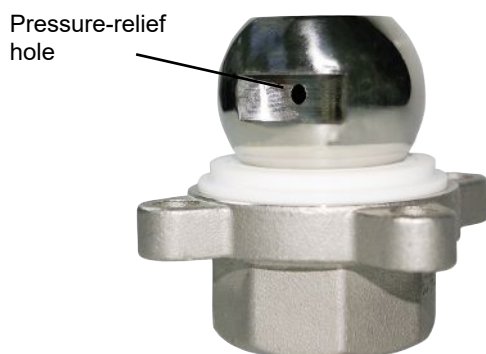

### Control ball

DN 15 to DN 100

Control ball	Code U	Code Y	Code W

Note: The control ball cannot be retrofitted to standard 2/2-way bodies at a later date.

## The spindle seal system

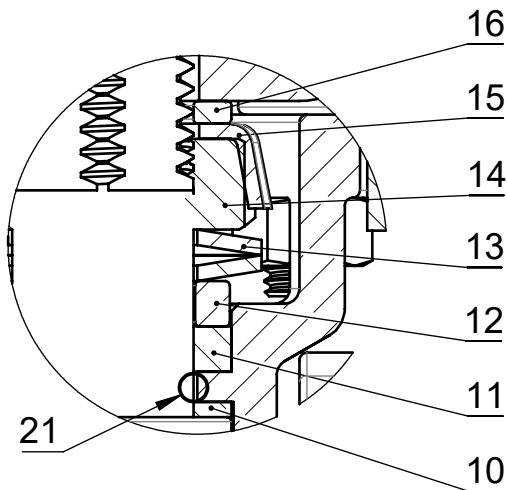

Item	Name	Material
10	Seal	PTFE
11	V-ring	PTFE
12	Stainless steel sleeve	SS304-1.4301
13	Spring washer	SS304-1.4301
14	Spindle nut	A2 70
15	Cap	SS304-1.4301
16	Washer	SS304-1.4301
21	O-ring (spindle seal)	Viton

### Long service life due to triple spindle seal

#### - Conical spindle seal:

The seal **10** arranged at an angle of 45° effectively prevents the leakage of media when operating the spindle

#### - O-ring:

Stabilising spindle seal **21** with low wear and long service life

#### - Pretensioned self-adjusting spindle seal:

The spindle packing consists of several V-rings **11**, a spring washer **13** and a stainless steel sleeve **12**. The spring washer **13** is pretensioned via the spindle nut **14**. The pretension force is distributed to the V-rings **11** via the stainless steel sleeve **12**, thereby preventing the leakage of media. The pretension provides low maintenance and reliable spindle sealing even after a long service life.

## GEMÜ CONEXO

The interaction of valve components that are equipped with RFID chips and an associated IT infrastructure actively increase process reliability.



Thanks to serialization, every valve and every relevant valve component such as the body, actuator or diaphragm, and even automation components, can be clearly traced and read using the CONEXO pen RFID reader. The CONEXO app, which can be installed on mobile devices, not only facilitates and improves the "installation qualification" process, but also makes the maintenance process much more transparent and easier to document. The app actively guides the maintenance technician through the maintenance schedule and directly provides him with all the information assigned to the valve, such as test reports, testing documentation and maintenance histories. The CONEXO portal acts as a central element, helping to collect, manage and process all data.

**For further information on GEMÜ CONEXO please visit:**

[www.gemu-group.com/conexo](http://www.gemu-group.com/conexo)

### Ordering

GEMÜ Conexo must be ordered separately with the ordering option "CONEXO" (see order data).

### Installing the RFID chip

In the corresponding design with CONEXO, this product has an RFID chip (1) for electronic recognition. The position of the RFID chip can be seen below.

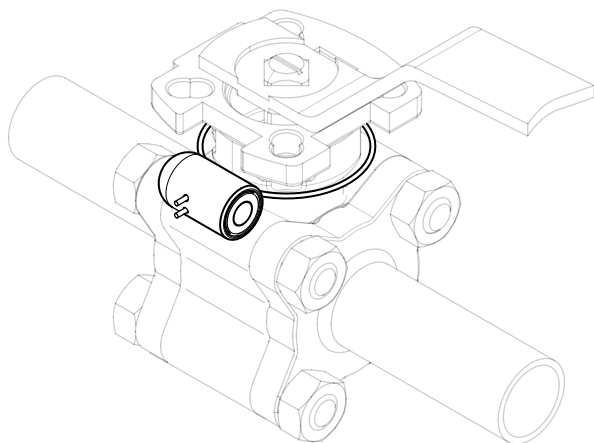

## Application

- Heating systems
- Beverage industry
- Foodstuff industry
- Chemical industry
- Drinking water installations
- Processing industry
- HVAC

## Availability

Connection types <sup>1)</sup>	Body materials <sup>2)</sup>	
	Code 37	Code C7
<b>Spigot (code 19, 59, 60)</b>	-	X
<b>Threaded socket (code 1, 31)</b>	X	-
<b>Flange (code 8, 11)</b>	X	-

### 1) Connection type

Code 1: Threaded socket DIN ISO 228

Code 31: Threaded socket NPT

Code 8: Flange EN 1092, PN 16, form B, face-to-face dimension FTF EN 558 series 1, ISO 5752, basic series 1

Code 11: Flange EN 1092, PN 40, form B, face-to-face dimension FTF EN 558 series 1, ISO 5752, basic series 1

Code 19: Spigot DIN EN 12627

Code 59: Spigot ASME BPE

Code 60: Spigot ISO 1127/EN 10357 series C/DIN 11866 series B

### 2) Ball valve material

Code 37: 1.4408 / CF8M (body, connection), 1.4401 / SS316 (ball, shaft)

Code C7: 1.4408 / CF8M (body), 1.4409 / CF3M (connection), 1.4401 / SS316 (ball, shaft)

## Order data

The order data provide an overview of standard configurations.

Please check the availability before ordering. Other configurations available on request.

### Order codes

1 Type	Code
Ball valve body, metal, 3-piece, ISO 5211, top flange	BB02

2 DN	Code
DN 8	8
DN 10	10
DN 15	15
DN 20	20
DN 25	25
DN 32	32
DN 40	40
DN 50	50
DN 65	65
DN 80	80
DN 100	100

3 Body/ball configuration	Code
2/2-way body	D
2/2-way body, V-ball 30° (for Kv value see datasheet)	U
2/2-way body, V-ball 90° (for Kv value see datasheet)	W
2/2-way body, V-ball 60° (for Kv value see datasheet)	Y

4 Connection type	Code
Spigot	
Spigot DIN EN 12627	19
Spigot ASME BPE	59

4 Continuation of Connection type	Code
Spigot ISO 1127/EN 10357 series C/DIN 11866 series B	60
<b>Threaded socket</b>	
Threaded socket DIN ISO 228	1
Threaded socket NPT	31
<b>Flange</b>	
Flange EN 1092, PN 16, form B, face-to-face dimension FTF EN 558 series 1, ISO 5752, basic series 1	8
Flange EN 1092, PN 40, form B, face-to-face dimension FTF EN 558 series 1, ISO 5752, basic series 1	11

5 Ball valve material	Code
1.4408 / CF8M (body, connection), 1.4401 / SS316 (ball, shaft)	37
1.4408 / CF8M (body), 1.4409 / CF3M (connection), 1.4401 / SS316 (ball, shaft)	C7

6 Seal material	Code
PTFE	5

7 Special version	Code
Without	
ATEX version	X

8 CONEXO	Code
without	
Integrated RFID chip for electronic identification and traceability	C

### Order example

Order option	Code	Description
1 Type	BB02	Ball valve body, metal, 3-piece, ISO 5211, top flange
2 DN	15	DN 15
3 Body/ball configuration	D	2/2-way body
4 Connection type	1	Threaded socket DIN ISO 228
5 Ball valve material	37	1.4408 / CF8M (body, connection), 1.4401 / SS316 (ball, shaft)
6 Seal material	5	PTFE
7 Special version		Without
8 CONEXO	C	Integrated RFID chip for electronic identification and traceability

## Technical data

### Medium

**Working medium:** Corrosive, inert, gaseous and liquid media and steam which have no negative impact on the physical and chemical properties of the body and seal material.

### Temperature

**Media temperature:** Connection code 19, 59, 60 -10 to 180 °C  
 Connection code 1, 31, 8, 11 -20 to 180 °C

**Ambient temperature:** -20 – 60 °C

**Storage temperature:** -60 – 60 °C

### Pressure

**Operating pressure:** 0 to 63 bar

**Pressure/temperature diagram:**

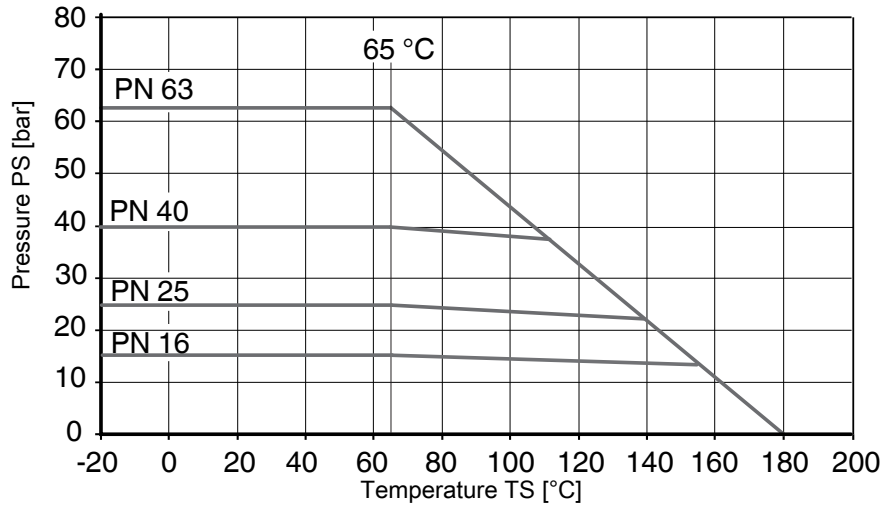

Note media temperature

**Leakage rate:** Leakage rate according to ANSI FCI70 – B16.104  
 Leakage rate according to EN12266, 6 bar air, leakage rate A

**Kv values:**

DN	NPS	Kv values
8	1/4"	8.0
10	3/8"	8.0
15	1/2"	17.0
20	3/4"	34.0
25	1"	60.0
32	1¼"	94.0
40	1½"	213.0
50	2"	366.0
65	2½"	595.0
80	3"	935.0
100	4"	1700.0

Kv values in m³/h



**Kv values:**

**V-ball 30° (code U)**

DN	NPS	Opening angle										
		0	15%	20%	30%	40%	50%	60%	70%	80%	90%	100%
8	1/4"	0	0.019	0.044	0.088	0.151	0.232	0.327	0.446	0.576	0.727	0.885
10	3/8"	0	0.021	0.05	0.1	0.172	0.265	0.374	0.51	0.659	0.83	1.012
15	1/2"	0	0.085	0.085	0.17	0.255	0.425	0.68	0.935	1.36	1.87	2.21
20	3/4"	0	0.085	0.17	0.425	0.595	0.935	1.53	2.04	2.805	3.825	4.59
25	1"	0	0.085	0.255	0.68	1.105	1.955	2.975	4.335	8.33	7.225	8.5
32	1 1/4"	0	0.17	0.34	0.935	1.7	3.145	4.675	6.8	8.5	11.05	12.75
40	1 1/2"	0	0.255	0.51	1.36	2.55	4.25	6.375	9.35	11.9	14.45	17.0
50	2"	0	0.34	1.02	3.23	5.1	8.5	12.75	19.55	26.35	36.55	51.0
65	2 1/2"	0	0.34	0.85	3.4	6.8	10.2	15.3	23.8	31.45	52.7	63.75
80	3"	0	0.425	1.02	3.4	6.8	11.9	19.55	28.05	39.1	55.25	69.7
100	4"	0	0.51	1.7	5.1	12.75	24.65	40.8	60.35	85.0	110.5	135.2

Kv values in m³/h

**V-ball 60° (code V)**

DN	NPS	Opening angle										
		0	15%	20%	30%	40%	50%	60%	70%	80%	90%	100%
8	1/4"	0	0.026	0.06	0.141	0.249	0.372	0.539	0.762	1.034	1.38	1.845
10	3/8"	0	0.03	0.068	0.161	0.285	0.425	0.616	0.871	1.182	1.577	2.108
15	1/2"	0	0.085	0.085	0.255	0.425	0.765	1.19	1.7	2.805	3.74	5.1
20	3/4"	0	0.085	0.17	0.595	0.85	1.445	2.38	3.4	5.525	7.65	10.2
25	1"	0	0.17	0.34	0.935	1.53	2.89	4.505	6.715	10.46	13.01	17.85
32	1 1/4"	0	0.17	0.51	1.53	2.55	4.675	8.075	10.88	16.15	22.1	33.15
40	1 1/2"	0	0.34	0.68	2.125	3.4	6.8	11.05	16.15	22.95	34.0	44.2
50	2"	0	0.34	1.275	3.91	7.65	14.03	22.95	33.15	46.75	70.55	93.5
65	2 1/2"	0	0.34	1.275	4.25	8.5	17.85	28.9	45.05	63.75	87.55	127.5
80	3"	0	0.425	2.125	5.1	11.9	21.25	34.0	55.25	77.35	108.8	140.3
100	4"	0	0.595	2.55	9.35	21.25	34.0	50.15	76.5	119.9	180.2	302.6

Kv values in m³/h

**V-ball 90° (code W)**

DN	NPS	Opening angle										
		0	15%	20%	30%	40%	50%	60%	70%	80%	90%	100%
8	1/4"	0	0.037	0.086	0.212	0.39	0.658	1.008	1.391	1.837	2.332	3.012
10	3/8"	0	0.043	0.098	0.242	0.446	0.752	1.152	1.59	2.1	2.665	3.443
15	1/2"	0	0.085	0.17	0.34	0.51	0.765	1.275	1.87	3.23	4.59	5.865
20	3/4"	0	0.17	0.34	0.68	1.02	1.7	2.635	3.91	6.8	9.605	11.9
25	1"	0	0.17	0.51	1.53	2.89	4.335	6.885	9.69	13.6	17.85	24.65
32	1 1/4"	0	0.255	0.68	1.7	4.25	6.8	11.9	16.15	23.8	33.15	46.75
40	1 1/2"	0	0.425	0.765	2.975	5.95	11.05	17.0	26.35	35.7	53.55	66.3
50	2"	0	0.595	1.7	5.1	10.2	18.7	29.75	38.25	59.5	89.25	114.8
65	2 1/2"	0	0.425	1.445	5.95	11.9	23.8	40.8	59.5	90.1	136.0	185.3
80	3"	0	0.595	2.975	6.8	15.3	29.75	51.0	76.5	114.8	174.3	263.5
100	4"	0	0.85	2.975	13.6	34.0	63.75	106.3	161.5	250.8	375.7	569.5

Kv values in m³/h

**Pressure rating:**

DN	Connection type code <sup>1)</sup>					
	60	19	1, 31	11	8	59
8	PN63	PN63	PN63	-	-	-
10	PN63	PN63	PN63	-	-	-
15	PN63	PN63	PN63	PN40	-	PN63
20	PN63	PN63	PN63	PN40	-	PN63
25	PN63	PN63	PN63	PN40	-	PN63
32	PN63	PN63	PN63	PN40	-	-
40	PN63	PN63	PN63	PN40	-	PN63
50	PN63	PN63	PN63	PN40	-	PN63
65	PN40	PN40	PN40	PN40	-	PN40
80	PN40	PN40	PN40	-	PN16	PN40
100	PN25	PN25	PN25	-	PN16	PN25

1) **Connection type**

Code 1: Threaded socket DIN ISO 228

Code 31: Threaded socket NPT

Code 8: Flange EN 1092, PN 16, form B, face-to-face dimension FTF EN 558 series 1, ISO 5752, basic series 1

Code 11: Flange EN 1092, PN 40, form B, face-to-face dimension FTF EN 558 series 1, ISO 5752, basic series 1

Code 19: Spigot DIN EN 12627

Code 59: Spigot ASME BPE



Code 60: Spigot ISO 1127/EN 10357 series C/DIN 11866 series B



**Product conformities**

**Pressure Equipment Directive:** 2014/68/EU

**Explosion protection:** ATEX (2014/34/EU), order code Special version X

**ATEX marking:**

**Up to DN 65**  
 Gas:  II 2G Ex h IIC T6 ... T2 Gb X  
 Dust:  II -/2D Ex h -/IIIC T180 °C -/Db X

**DN 80 and 100**  
 Gas:  II 2G Ex h IIB T6 ... T2 Gb X  
 Dust:  II -/2D Ex h -/IIIC T180 °C -/Db X

**Mechanical data****Weight:****Ball valve**

DN	NPS	Threaded connection, spigot	Flange
8	1/4"	0.55	1.15
10	3/8"	0.55	1.15
15	1/2"	0.6	1.35
20	3/4"	0.7	1.45
25	1"	0.8	1.8
32	1¼"	1.2	2.4
40	1½"	2.3	3.5
50	2"	3.5	4.9
65	2½"	6.9	9.3
80	3"	11.7	14.7
100	4"	19.3	22.3

Weights in kg

**Torques:**

DN	NPS	Breakaway torque
8	1/4"	6.0
10	3/8"	6.0
15	1/2"	6.0
20	3/4"	10.0
25	1"	11.0
32	1¼"	17.0
40	1½"	28.0
50	2"	53.0
65	2½"	76.0
80	3"	89.0
100	4"	138.0

Torques in Nm

A safety factor of 1.2 is included

With dry, non-lubricating media the breakaway torque may be increased.

Valid for clean, non-particulate and oil-free media (water, alcohol, etc.), gas or saturated steam (clean and wet).

PTFE seal.

## Dimensions

### Actuator flange

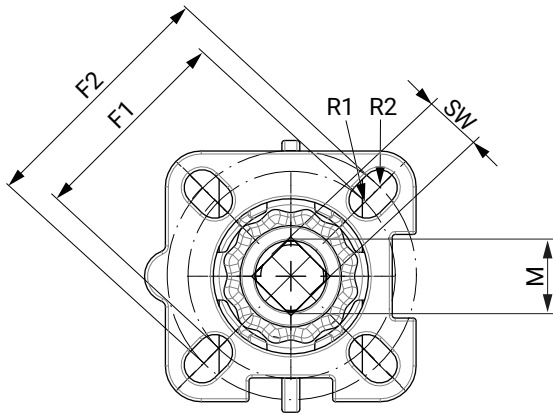

DN	G	F1	ISO 5211	R1	F2	ISO 5211	R2	SW	M
8	1/4"	36.0	F03	3.0	42.0	F04	3.0	9.0	M12
10	3/8"	36.0	F03	3.0	42.0	F04	3.0	9.0	M12
15	1/2"	36.0	F03	3.0	42.0	F04	3.0	9.0	M12
20	3/4"	36.0	F03	3.0	42.0	F04	3.0	9.0	M12
25	1"	42.0	F04	3.5	50.0	F05	3.5	11.0	M14
32	1 1/4"	42.0	F04	3.5	50.0	F05	3.5	11.0	M14
40	1 1/2"	50.0	F05	4.5	70.0	F07	3.5	14.0	M18
50	2"	50.0	F05	4.5	70.0	F07	3.5	14.0	M18
65	2 1/2"	50.0	F07	4.5	70.0	F10	3.5	17.0	M22
80	3"	70.0	F07	5.5	102.0	F10	4.5	17.0	M22
100	4"	102.0	F10	5.5	125.0	F12	4.5	17.0	M22

Dimensions in mm

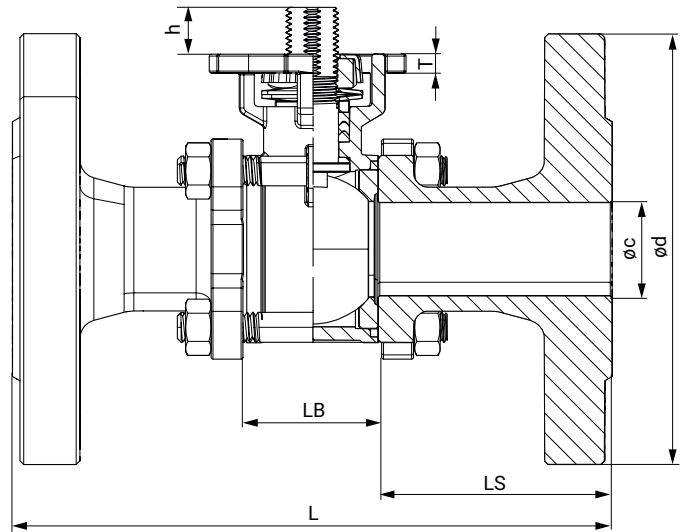
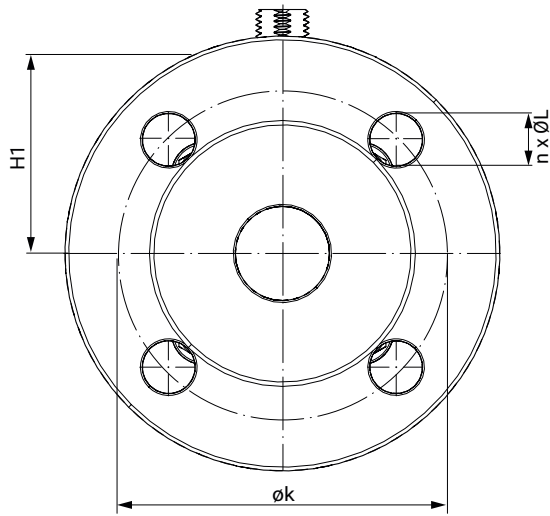
**Body dimensions****Flange (connection code 8, 11)**

DN	Connection code	$\text{øc}$	$\text{ød}$	$\text{øk}$	$h$	$L$	$LB$	$LS$	$H1$	$T$	$n \times \text{ØL}$
15	11	15.0	95.0	65.0	9.0	130.0	24.0	53.0	40.5	5.5	4 x 14.0
20	11	20.0	105.0	75.0	10.5	150.0	29.0	60.5	45.0	5.5	4 x 14.0
25	11	25.0	115.0	85.0	12.5	160.0	35.0	62.5	52.0	5.0	4 x 14.0
32	11	32.0	140.0	100.0	12.5	180.0	44.0	68.0	57.0	6.5	4 x 18.0
40	11	38.0	150.0	110.0	16.0	200.0	53.0	73.5	69.0	7.5	4 x 18.0
50	11	50.0	165.0	125.0	16.0	230.0	65.0	82.5	77.0	8.5	4 x 18.0
65	11	65.0	185.0	145.0	15.0	290.0	81.0	104.5	90.0	8.5	8 x 18.0
80	8	80.0	200.0	160.0	18.0	310.0	96.0	107.0	108.0	10.0	8 x 18.0
100	8	100.0	220.0	180.0	18.0	350.0	124.0	113.0	123.0	10.0	8 x 18.0

Dimensions in mm

**Threaded socket (connection code 1, 31)**

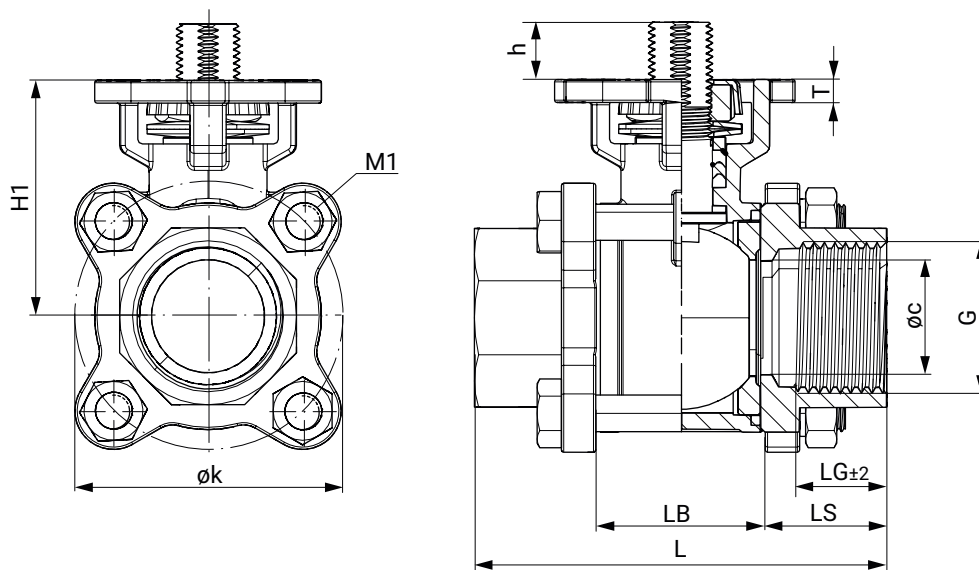

DN	G	øc	øk	h	LG	L	LB	LS	H1	M1	T
8	1/4"	10.0	46.0	9.0	12.0	55.0	24.0	25.5	40.5	M8	5.5
10	3/8"	12.0	46.0	9.0	12.0	60.0	24.0	25.5	40.5	M8	5.5
15	1/2"	15.0	46.0	9.0	16.0	75.0	24.0	25.5	40.5	M8	5.5
20	3/4"	20.0	51.0	10.5	16.0	80.0	29.0	25.5	45.0	M8	5.5
25	1"	25.0	61.0	12.5	17.0	90.0	35.0	27.5	52.0	M8	5.0
32	1¼"	32.0	73.0	12.5	20.0	110.0	44.0	33.0	57.0	M10	6.5
40	1½"	38.0	83.0	16.0	22.0	120.0	53.0	33.5	69.0	M10	7.5
50	2"	49.0	101.0	16.0	24.0	140.0	65.0	37.5	77.0	M12	8.5
65	2½"	64.0	130.0	15.0	28.0	185.0	81.0	52.0	90.0	M12	8.5
80	3"	76.0	155.0	18.0	32.0	205.0	96.0	54.5	108.0	M14	10.0
100	4"	100.0	187.0	18.0	40.0	240.0	124.0	58.0	123.0	M14	10.0

Dimensions in mm

**Spigot ASME (connection code 59)**

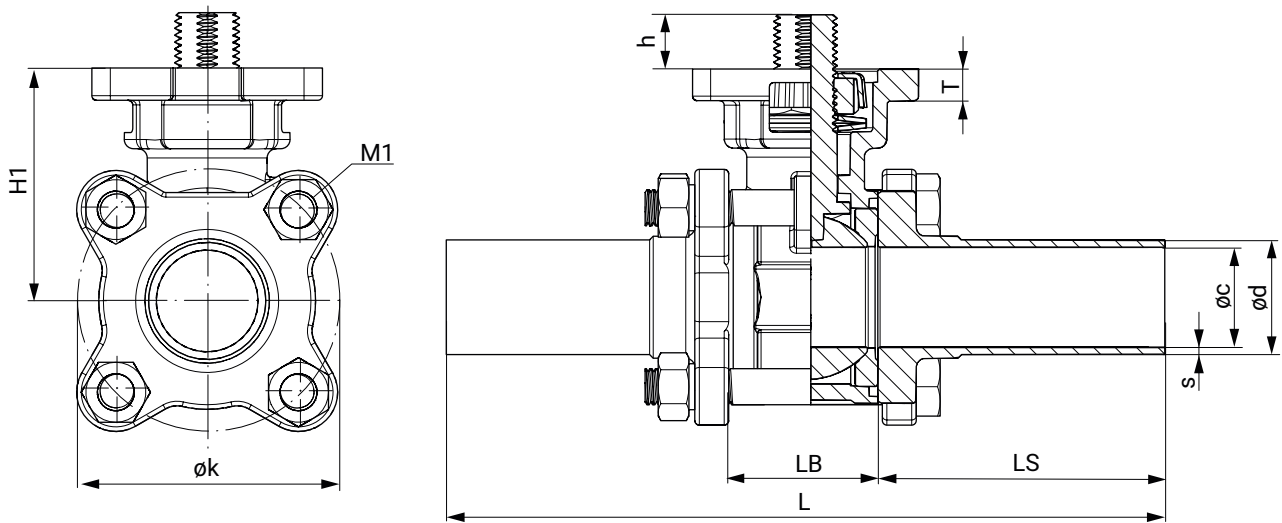

DN	øc	ød	h	øk	s	L	LB	LS	H1	M1	T
15	9.4	12.7	8.5	46.0	1.65	140.0	25.0	57.5	40.5	M8	5.0
20	15.7	19.0	10.5	47.0	1.65	146.0	28.0	59.0	43.5	M8	5.0
25	22.1	25.4	12.0	56.0	1.65	159.0	32.0	63.5	50.5	M8	7.0
40	34.8	38.1	14.5	79.0	1.65	191.0	48.0	71.5	67.5	M10	8.0
50	47.5	50.8	14.5	98.5	1.65	216.0	62.0	77.0	75.5	M12	8.0
65	60.2	63.5	14.5	126.0	1.65	248.0	80.0	84.0	88.0	M12	8.0
80	72.9	76.2	17.5	146.0	1.65	267.0	90.0	88.5	105.0	M14	10.0
100	97.4	101.6	17.5	180.0	2.15	318.0	118.0	100.0	120.0	M14	10.0

Dimensions in mm

**Spigot DIN EN 12627 (connection code 19)**

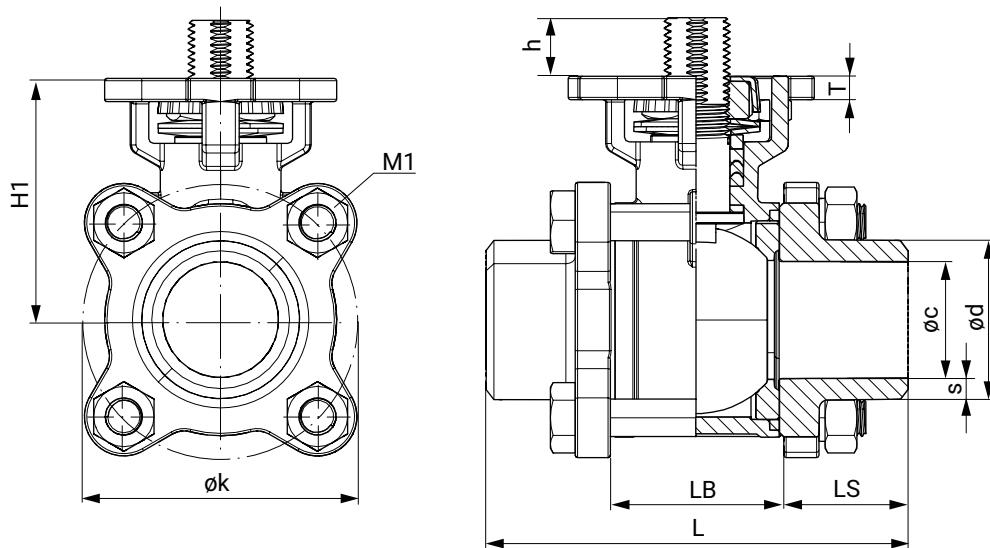

DN	øc	ød	øk	h	s	L	LB	LS	H1	M1	T
8	11.6	16.2	46.0	9.0	2.30	60.0	24.0	18.0	40.5	M8	5.5
10	12.7	17.5	46.0	9.0	2.40	60.0	24.0	18.0	40.5	M8	5.5
15	15.0	21.7	46.0	9.0	3.35	75.0	24.0	25.5	40.5	M8	5.5
20	20.0	27.2	51.0	10.5	3.60	80.0	29.0	25.5	45.0	M8	5.5
25	25.0	34.0	61.0	12.5	4.50	90.0	35.0	27.5	52.0	M8	5.0
32	32.0	42.7	73.0	12.5	5.35	110.0	44.0	33.0	57.0	M10	6.5
40	38.0	58.8	83.0	16.0	5.30	120.0	53.0	33.5	69.0	M10	7.5
50	50.0	60.5	101.0	16.0	5.25	140.0	65.0	37.5	77.0	M12	8.5
65	63.0	76.3	130.0	15.0	6.65	185.3	81.0	52.2	90.0	M12	8.5
80	76.0	89.0	155.0	18.0	6.50	205.0	96.0	54.5	108.0	M14	10.0
100	100.0	116.0	187.0	18.0	8.00	240.0	124.0	58.0	123.0	M14	10.0

Dimensions in mm

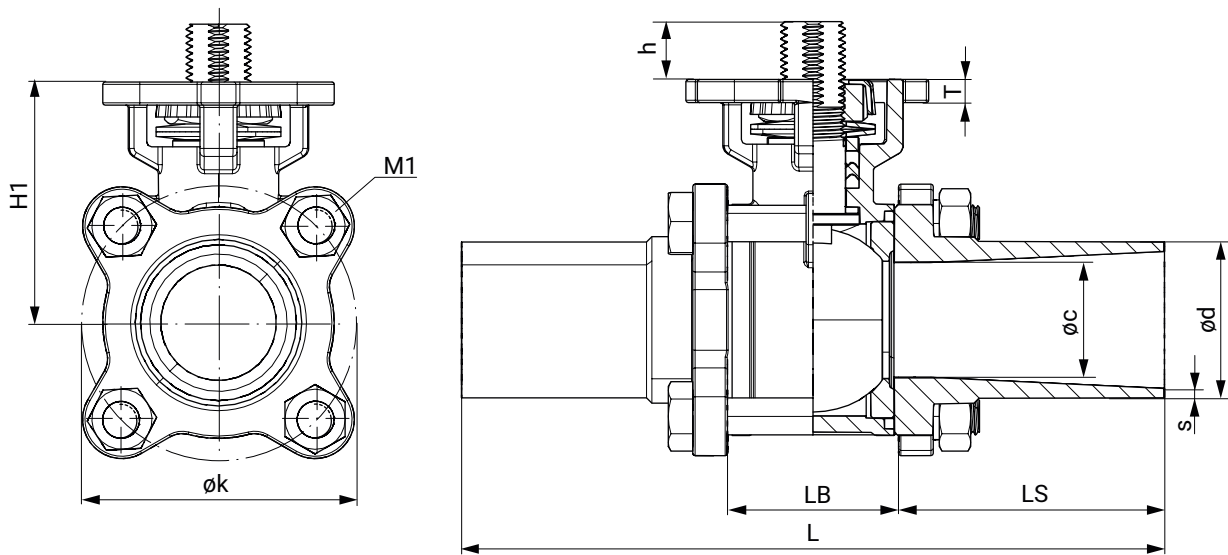

**Spigot ISO (connection code 60)**

DN	øc	ød	h	øk	s	L	LB	LS	H1	M1	T
8	10.3	13.5	9.0	46.0	1.6	120.0	24.0	48.0	40.5	M8	5.5
10	12.0	17.2	9.0	46.0	1.6	120.0	24.0	48.0	40.5	M8	5.5
15	15.0	21.3	9.0	46.0	1.6	140.2	24.0	58.0	40.5	M8	5.5
20	20.0	26.9	10.5	51.0	1.6	140.0	29.0	55.5	45.0	M8	5.5
25	25.0	33.7	12.5	59.0	2.0	152.2	35.0	58.5	52.0	M8	5.0
32	32.0	42.4	12.5	73.0	2.0	165.1	44.0	60.5	57.0	M10	6.5
40	38.0	48.3	16.0	83.0	2.0	190.4	53.0	68.5	69.0	M10	7.5
50	49.0	60.3	16.0	103.0	2.0	203.0	65.0	69.0	77.0	M12	8.5
65	64.0	76.1	15.0	130.0	2.0	254.0	81.0	86.5	90.0	M12	8.5
80	76.0	88.9	18.0	155.0	2.3	280.2	96.0	92.0	108.0	M14	10.0
100	100.0	114.3	18.0	187.0	2.3	317.0	124.0	96.5	123.0	M14	10.0

Dimensions in mm

## Add-on components



### GEMÜ ADA

#### Pneumatic quarter turn actuator

GEMÜ ADA is a pneumatic double acting quarter turn actuator. It works according to the double piston rack and pinion principle and is suitable for mounting to butterfly valves or ball valves.



### GEMÜ ASR

#### Pneumatic quarter turn actuator

GEMÜ ASR is a pneumatic single acting quarter turn actuator. It works according to the double piston rack and pinion principle and is suitable for mounting to butterfly valves or ball valves.



### GEMÜ 9428

#### Motorized quarter turn actuator

The product is a motorized quarter turn actuator. The actuator is designed for DC or AC operating voltages. A manual override and an optical position indicator are integrated as standard. The torque in the end positions is increased. This enables a closing curve matched to the valves.



### GEMÜ 9468

#### Motorized quarter turn actuator

GEMÜ 9468 is a motorized quarter turn actuator. A manual override and an optical position indicator are integrated as standard. The torque in the end positions is increased. This enables a closing curve matched to the valves.



### GEMÜ J4C

#### Motorized quarter turn actuator

The J4C actuator is a motorized quarter turn actuator. The motor is designed for DC and AC operating voltages. A manual override and an optical position indicator are integrated as standard. The end positions are potential-free and adjustable.



### GEMÜ AB22

#### Hand lever

Hand lever with standard flange according to EN ISO 5211 for the manual operation of quarter turn valves.

**Accessories**

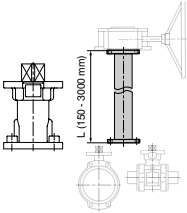

**GEMÜ RCO**

**Shaft extension**

The RCO shaft extension for quarter turn valves is a distance piece between manually, pneumatically or electrically operated valves. This means that valves can be protected from flooding or better access for operation of the valve can be ensured (also for manual override). The RCOS is made from steel and the RCOV is made from stainless steel.



**GEMÜ MSC**

**Mounting kit**

The MSC mounting kit is an interface, for the same and different ends, to join flange designs according to ISO 5211. This mounting kit ensures thermal separation of actuator and valve body. It can also be used as height compensation for insulated pipelines. The mounting kit is available in steel, electrogalvanized and stainless steel in an open or closed design.

**GEMÜ ADH**

**Mounting sleeve**

The mounting sleeve accessories are available in the square and star geometry designs. These are used for the shaft and hub support for quarter turn actuators. Both sleeves have an internal square drive (please observe stated measurement dimensions here). The sleeve material is sintered metal and they are chemically nickel plated with a surface of 25 µm.

**Certificates**

Certificate	Standard	Item number
3.1 Material analysis + pressure test	EN 10204	88333336



GEMÜ Gebr. Müller Apparatebau GmbH & Co. KG  
Fritz-Müller-Straße 6-8, 74653 Ingelfingen-Criesbach, Germany  
Phone +49 (0) 7940 1230 · info@gemu.de  
www.gemu-group.com